



US00D423411S

United States Patent [19]

Takei et al.

[11] **Patent Number: Des. 423,411**

[45] **Date of Patent: ** Apr. 25, 2000**

[54] **TRUCK**

[75] Inventors: **Tatsuya Takei**, Aichi-ken; **Teruo Sato**, Tokyo, both of Japan

[73] Assignees: **Toyota Jidosha Kabushiki Kaisha; Hino Jidosha Kogyo Kabushiki Kaisha**, both of Japan

[**] Term: **14 Years**

[21] Appl. No.: **29/104,481**

[22] Filed: **May 6, 1999**

[51] **LOC (6) Cl.** **12-08**

[52] **U.S. Cl.** **D12/93; D12/98**

[58] **Field of Search** **D12/93, 96, 98; 296/183, 180, 190; 180/89.12, 89.19, 89.16**

[56] **References Cited**

U.S. PATENT DOCUMENTS

- D. 266,756 11/1982 Magnini D12/98
- D. 344,472 2/1994 Savio D12/96
- D. 412,301 7/1999 Dirks D12/96

OTHER PUBLICATIONS

- Isuzu "Elf", Japanese Motor Vehicles Guide Book, vol. 39, Oct. 26, 1992, pp. 344-345.
- Isuzu "Elf", Japanese Motor Vehicles Guide Book, vol. 41, Oct. 25, 1994, p. 329.

Mitsubishi "Canter", Japanese Motor Vehicles Guide Book, vol. 43, Oct. 25, 1996, p. 347.

Primary Examiner—Melody N. Brown
Attorney, Agent, or Firm—Saidman DesignLaw Group

[57] **CLAIM**

The ornamental design for a truck, as shown and described.

DESCRIPTION

FIG. 1 is a front and side perspective view of a truck showing our new design;

FIG. 2 is a rear and side perspective view thereof;

FIG. 3 is a front view thereof;

FIG. 4 is a rear view thereof;

FIG. 5 is a top view thereof; and,

FIG. 6 is a right side view thereof, the left side being a mirror image.

The bottom view is omitted since we do not regard it as part of our claimed design.

1 Claim, 2 Drawing Sheets





FIG. 1

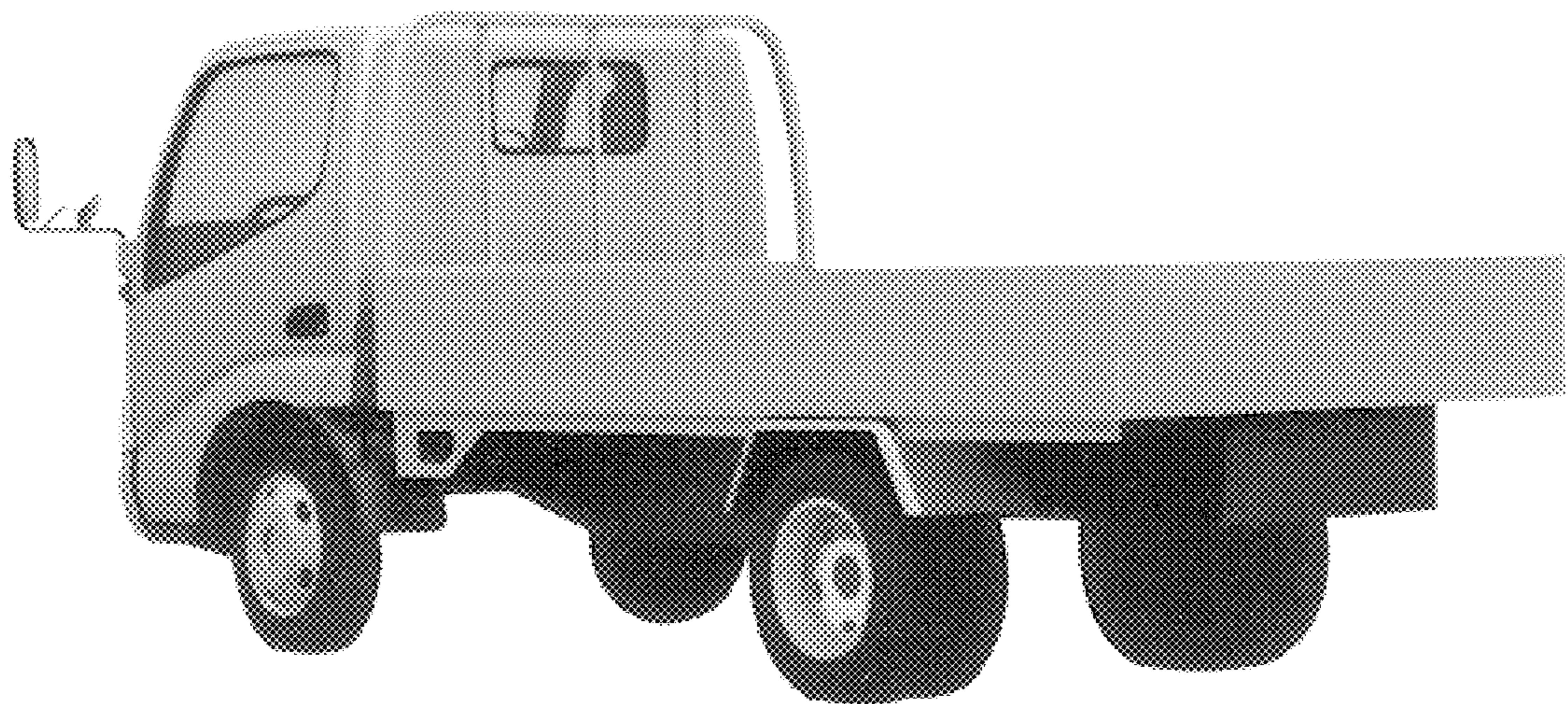

FIG. 2

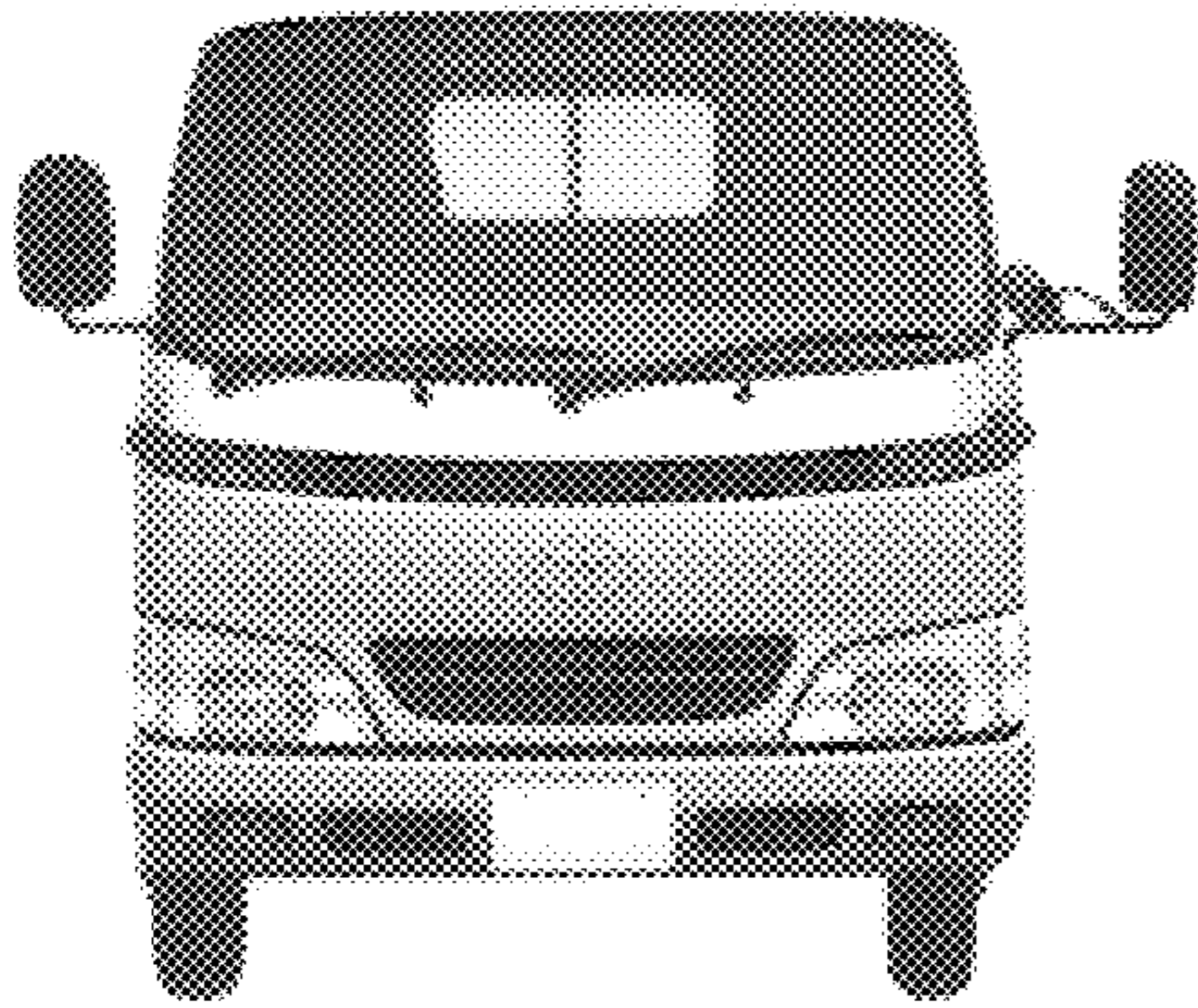

FIG. 3

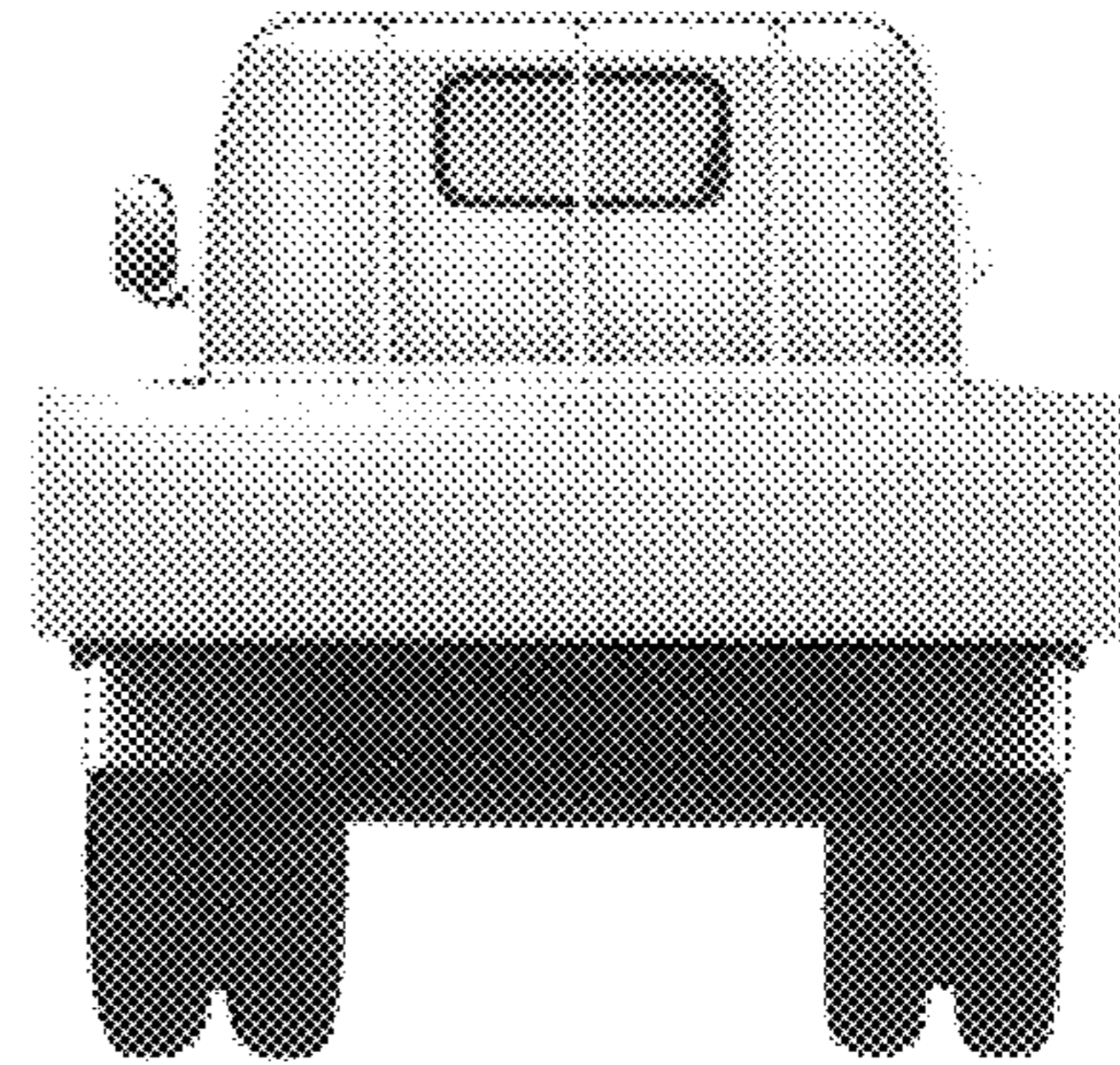

FIG. 4

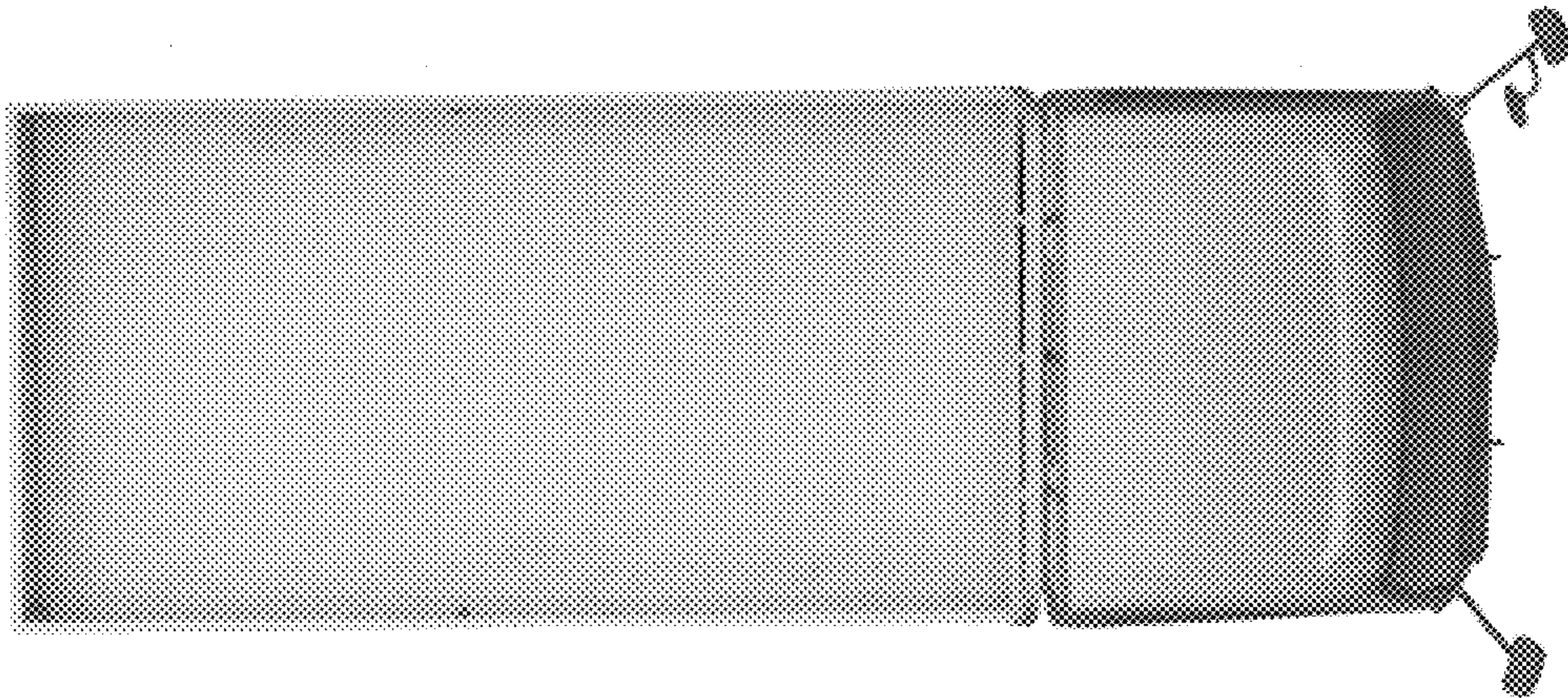

FIG. 5

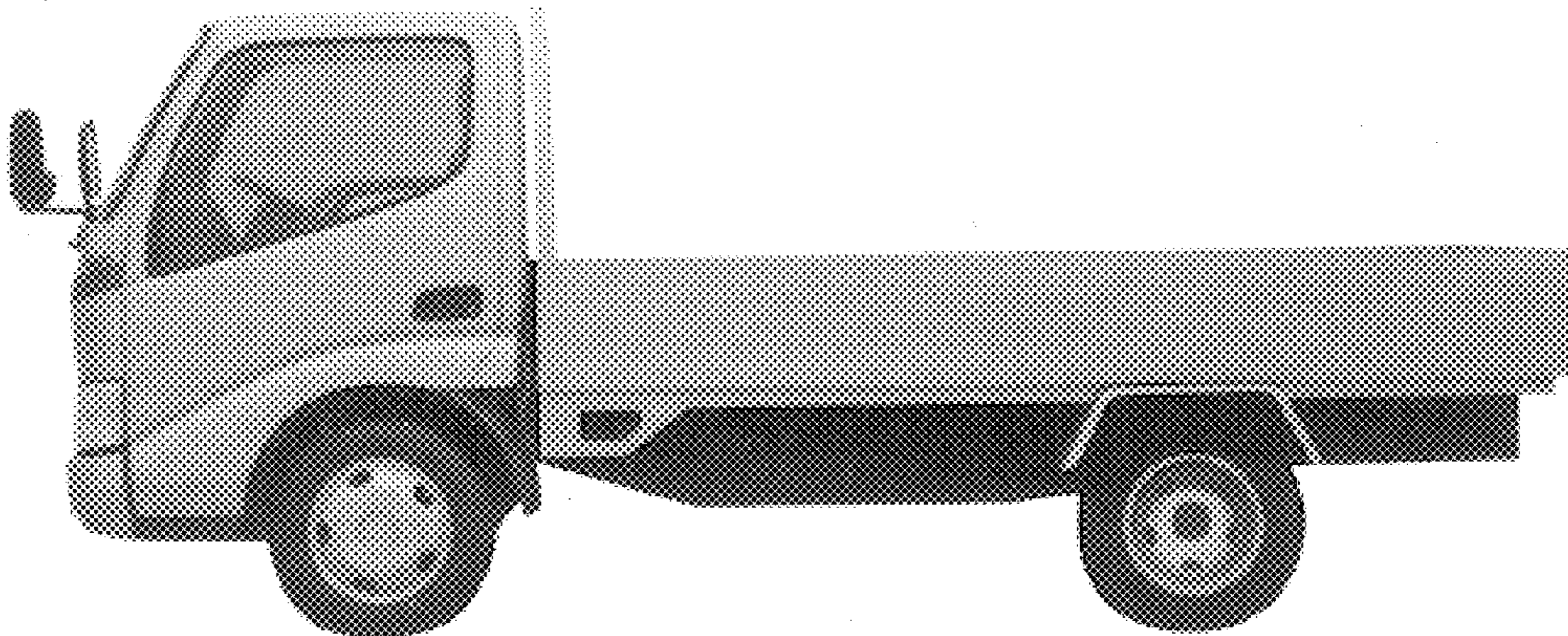

FIG. 6