



US00D423344S

United States Patent [19]

[11] **Patent Number: Des. 423,344**

Kumakura et al.

[45] **Date of Patent: ** Apr. 25, 2000**

[54] **CONTAINER FOR DRY BATTERY**
[75] Inventors: **Katsuhiko Kumakura**, Kyoto; **Tadashi Ono**, Osaka, both of Japan

4,361,231 11/1982 Patience 206/806 X
4,696,402 9/1987 Harmon et al. 206/705 X
5,735,404 4/1998 Kumakura et al. 206/469
5,947,297 9/1999 Aoki et al. 206/705

[73] Assignee: **Matsushita Electric Industrial Co., Ltd.**, Japan

FOREIGN PATENT DOCUMENTS

58-61756 4/1983 Japan .
59-164161 11/1984 Japan .
59-164162 11/1984 Japan .

[**] Term: **14 Years**

OTHER PUBLICATIONS

[21] Appl. No.: **29/106,398**

Modern Packaging Catalog, pp. 300, Jan. 1941.
Techform Inc. Blister Packs (From 206/461 Shoe), Nov. 1982.

[22] Filed: **Jun. 15, 1999**

[30] Foreign Application Priority Data

Dec. 25, 1998 [JP] Japan 10-37871

Primary Examiner—Prabhakar Deshmukh
Attorney, Agent, or Firm—Saidman DesignLaw Group

[51] **LOC (6) Cl.** **09-07**

[52] **U.S. Cl.** **D9/415; D9/341**

[57] CLAIM

[58] **Field of Search** D9/415, 418, 337,
D9/341, 346; 206/461-471, 495, 806, 769-773,
775-778, 701, 703-705, 349

The ornamental design for a container for dry battery, as shown and described.

DESCRIPTION

[56] References Cited

U.S. PATENT DOCUMENTS

D. 262,095 12/1981 Takahashi D9/415
D. 263,559 3/1982 Poore D9/337
D. 302,661 8/1989 Calcerano et al. D9/415
D. 353,092 12/1994 Green D9/415
D. 378,570 3/1997 MacEachern D9/415
D. 394,207 5/1998 Waterbury et al. D9/415
D. 408,732 4/1999 Gaffaney et al. D9/415
2,081,656 5/1937 Anthony 206/705 X

FIG. 1 is a perspective view of the top, front and left side of a container for dry battery showing our new design;
FIG. 2 is a top plan view thereof;
FIG. 3 is a front view thereof;
FIG. 4 is a right side view thereof;
FIG. 5 is a rear view thereof;
FIG. 6 is a left side view thereof; and,
FIG. 7 is a bottom view thereof.

1 Claim, 2 Drawing Sheets

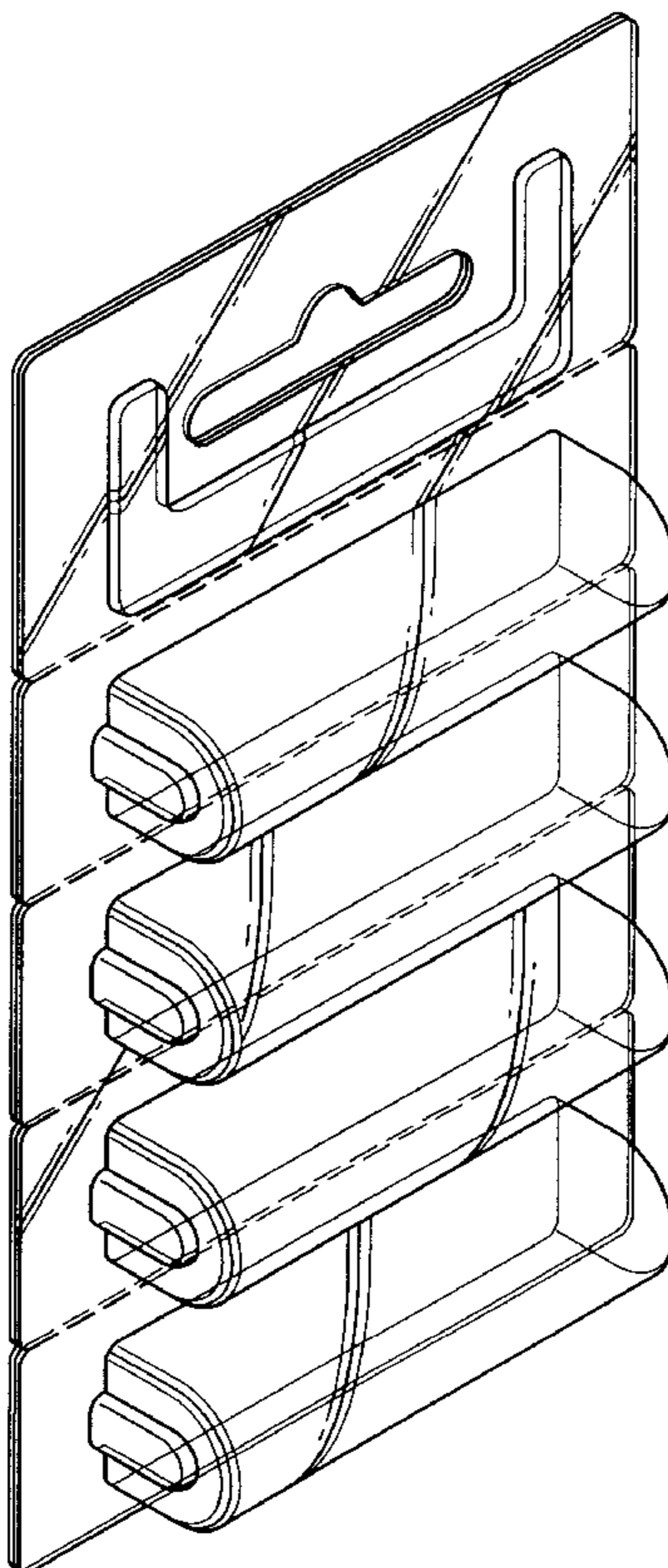

FIG. 1

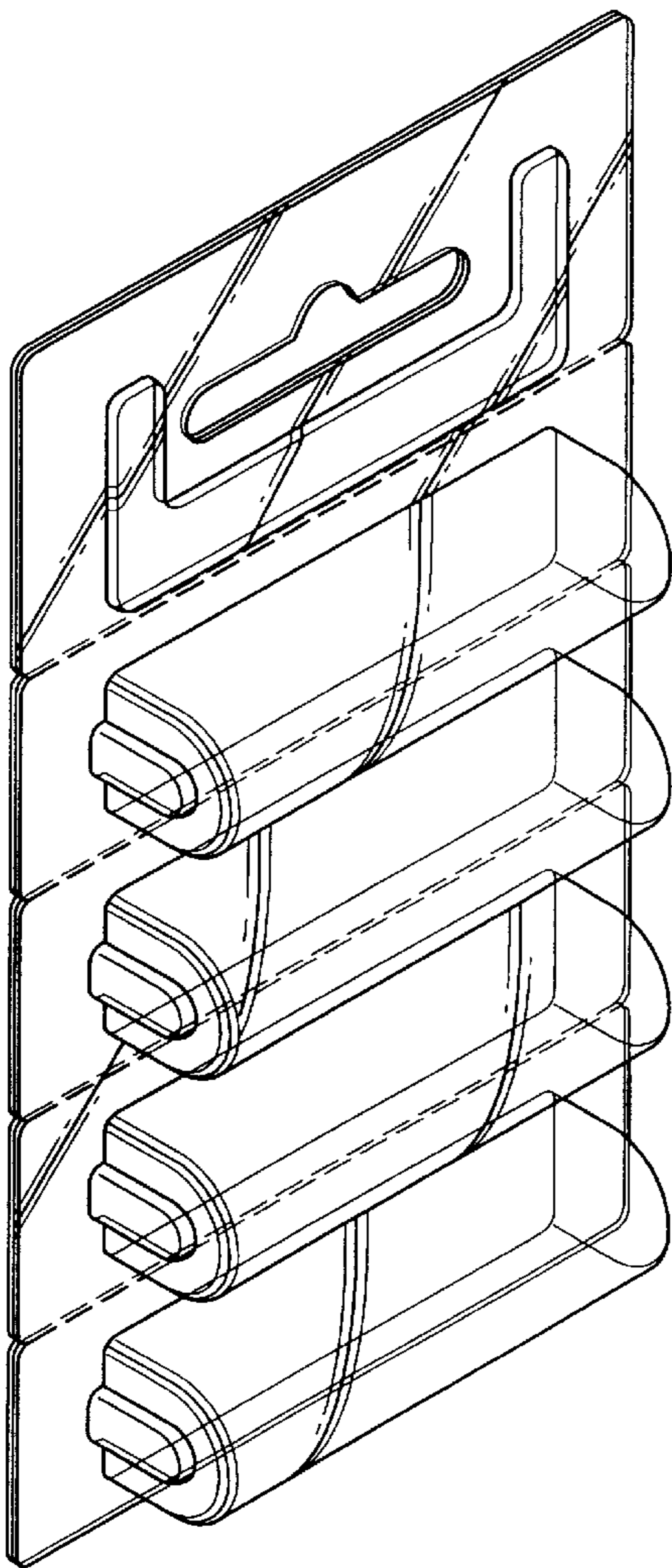

FIG. 2

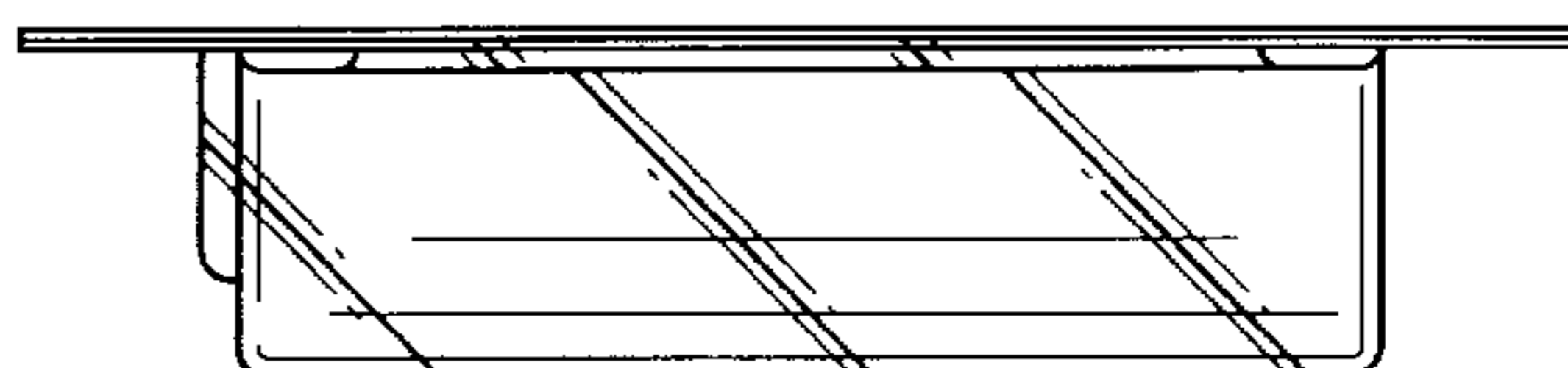

FIG. 3

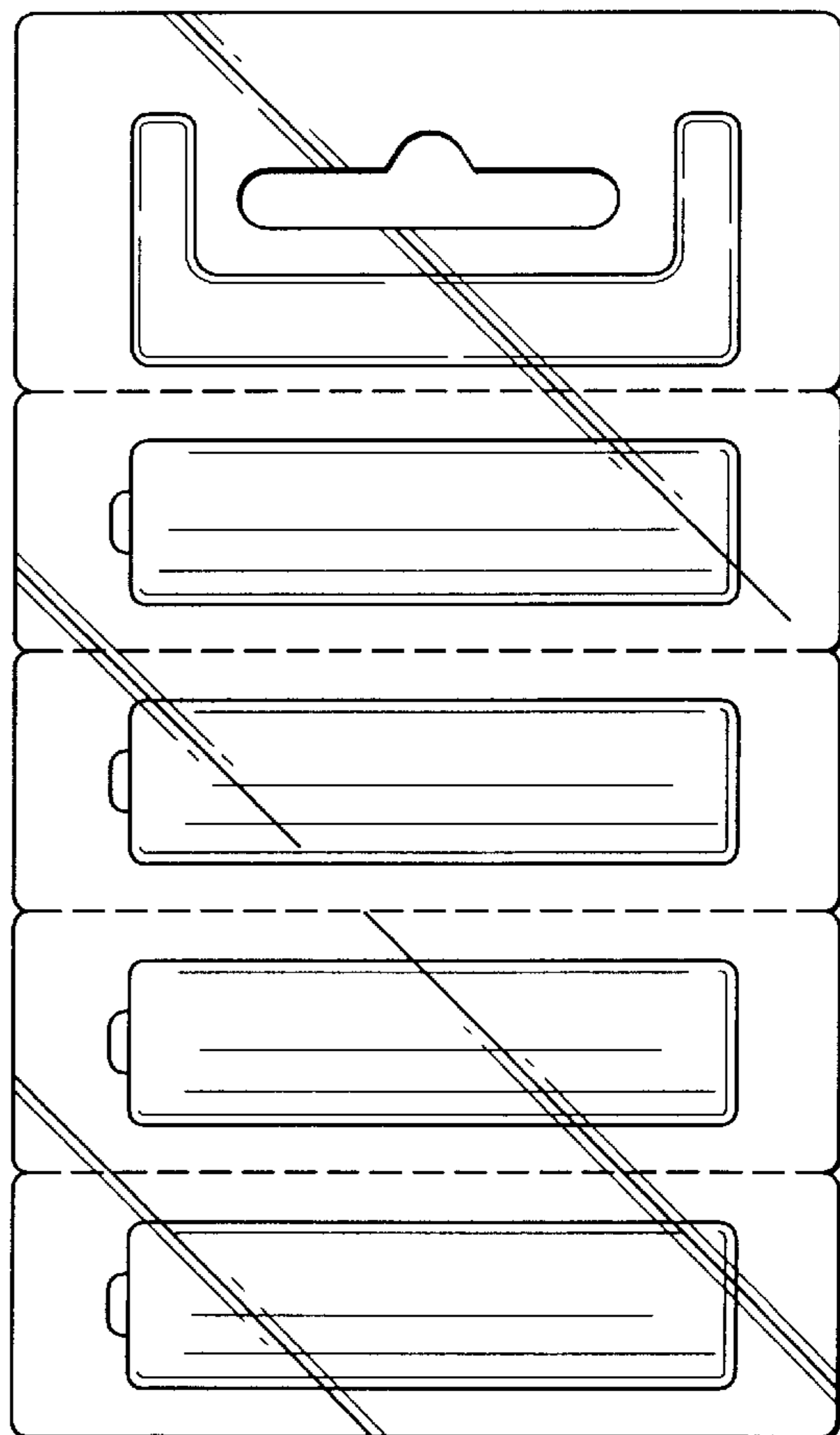

FIG. 4

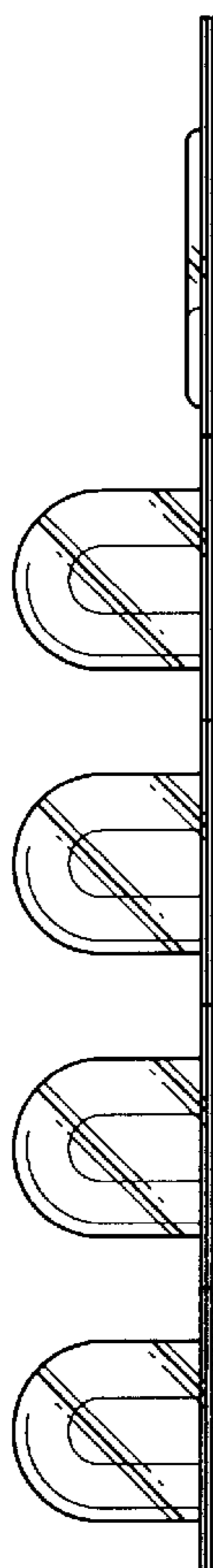

FIG. 5

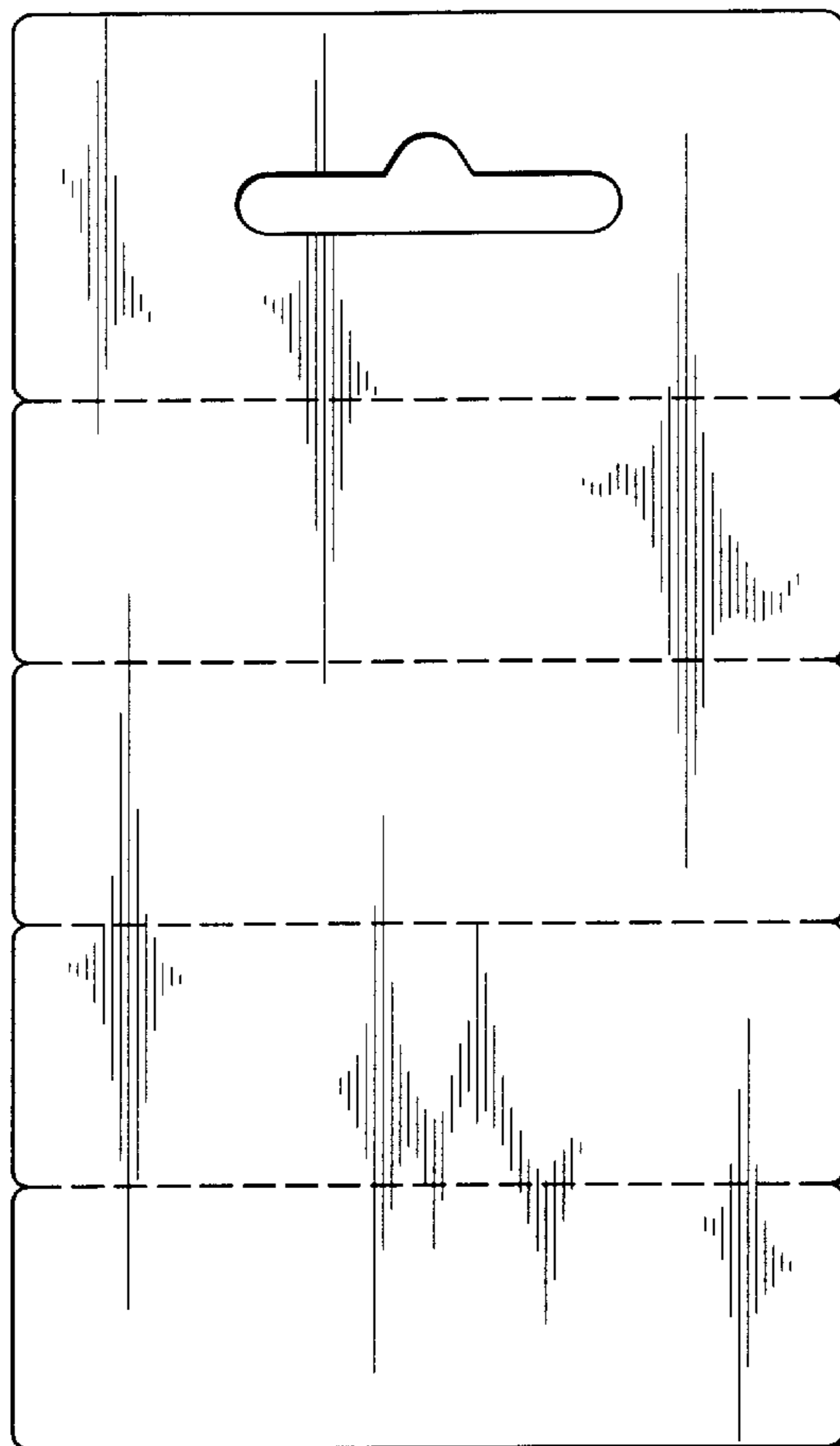

FIG. 6

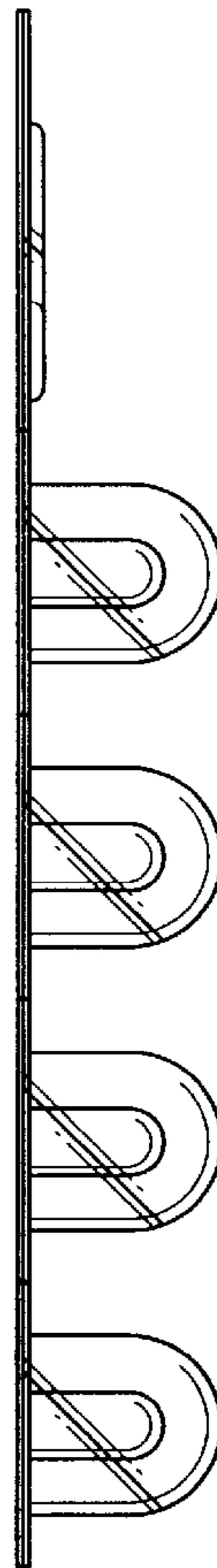

FIG. 7

