



US00D423017S

United States Patent [19]
McGowan

[11] **Patent Number: Des. 423,017**

[45] **Date of Patent: ** Apr. 18, 2000**

[54] **SKEG**

[75] Inventor: **Philip James McGowan**, Grayslake, Ill.

[73] Assignee: **Outboard Marine Corporation**, Waukegan, Ill.

[**] Term: **14 Years**

[21] Appl. No.: **29/105,029**

[22] Filed: **May 17, 1999**

[51] **LOC (6) Cl.** **15-01**

[52] **U.S. Cl.** **D15/4**

[58] **Field of Search** D15/1, 4; 440/66, 440/76, 78, 80, 88

[56] **References Cited**

U.S. PATENT DOCUMENTS

3,952,687	4/1976	Brownville	D15/4
4,304,557	12/1981	Henrich	440/76
5,277,634	1/1994	Calamia	440/78
5,344,349	9/1994	Meisenburg et al.	440/80

Primary Examiner—Ralf Seifert
Attorney, Agent, or Firm—Armstrong Teasdale LLP

[57] **CLAIM**

I claim the ornamental design for a skreg, as shown and described.

DESCRIPTION

FIG. 1 is a perspective view of an outboard engine including a skreg portion.

FIG. 2 is a left side view of the skreg portion and torpedo portion shown in FIG. 1.

FIG. 3 is a right side view of the skreg portion and torpedo portion shown in FIG. 1.

FIG. 4 is a rear view of the skreg portion and torpedo portion shown in FIG. 1.

FIG. 5 is a front view of the skreg portion and torpedo portion shown in FIG. 1.

FIG. 6 is a bottom view of the skreg portion and torpedo portion shown in FIG. 1; and,

FIG. 7 is a top view of the skreg portion and torpedo portion shown in FIG. 1.

1 Claim, 2 Drawing Sheets

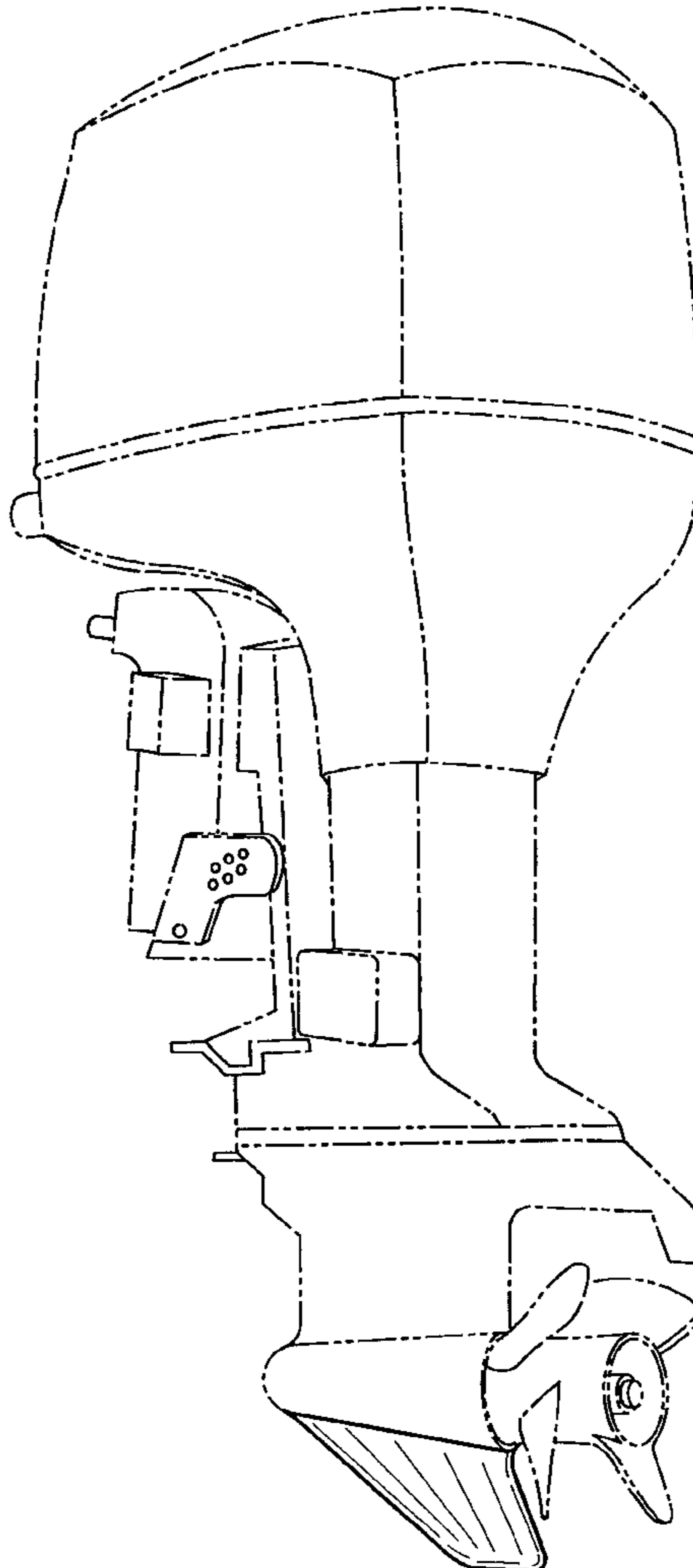

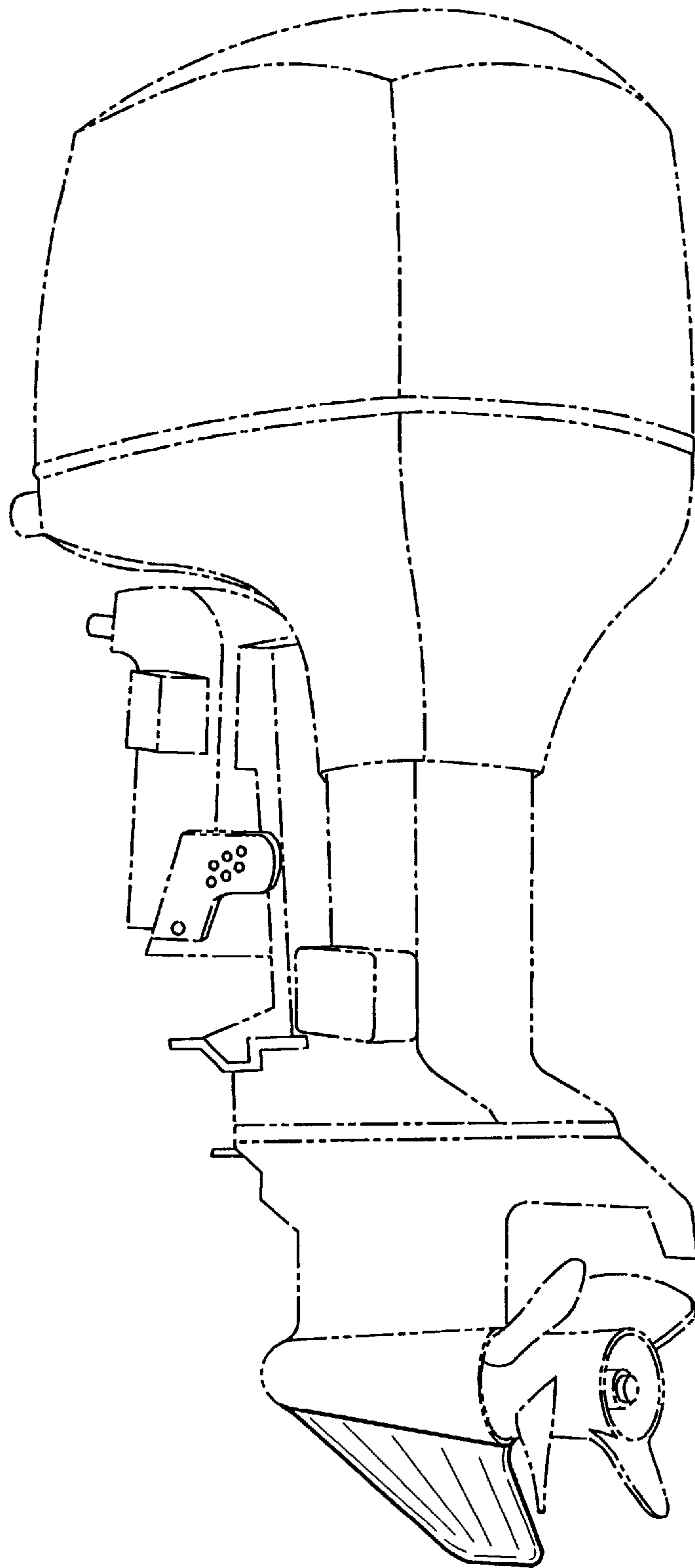

FIG. 1

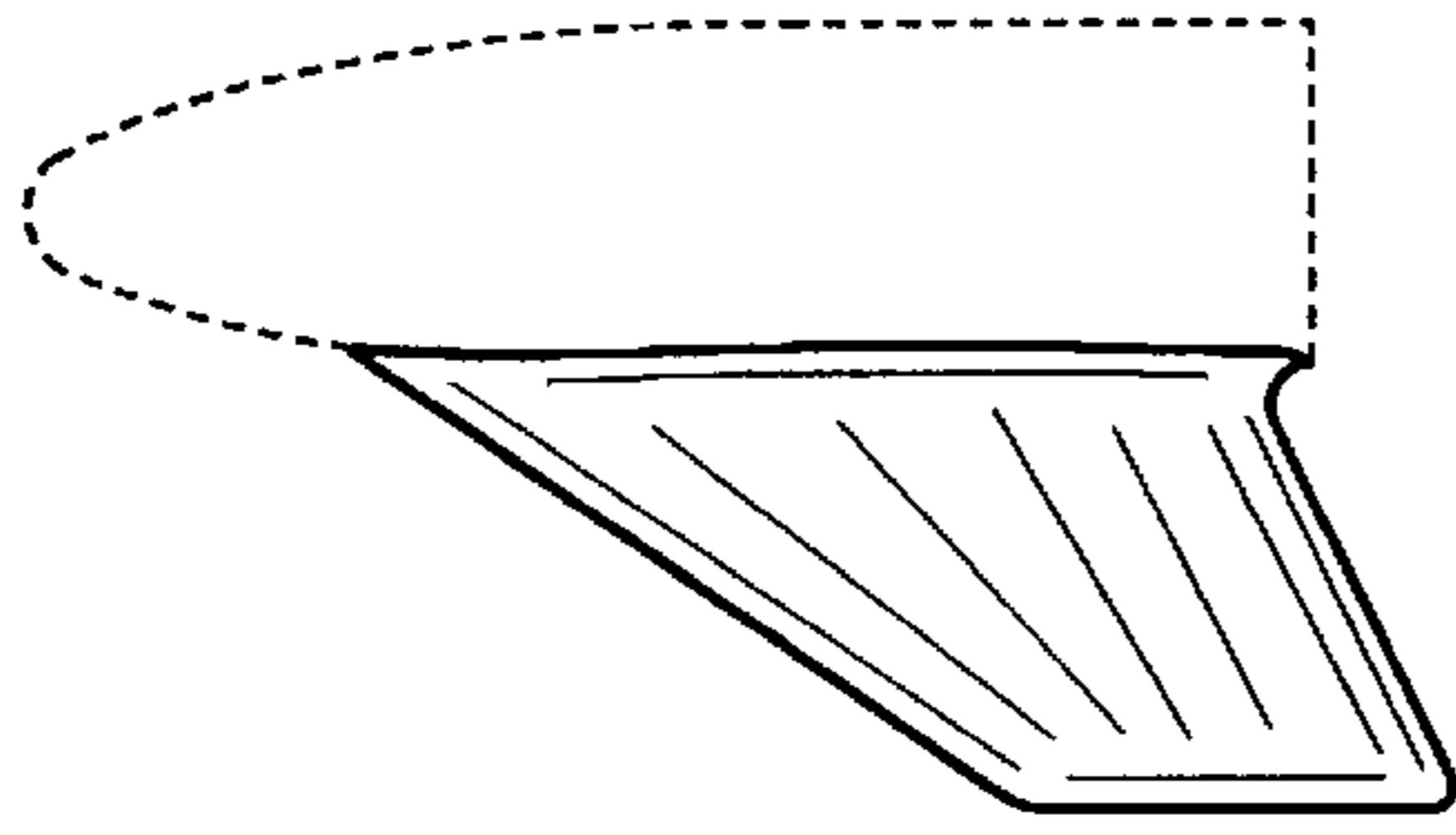

FIG. 2

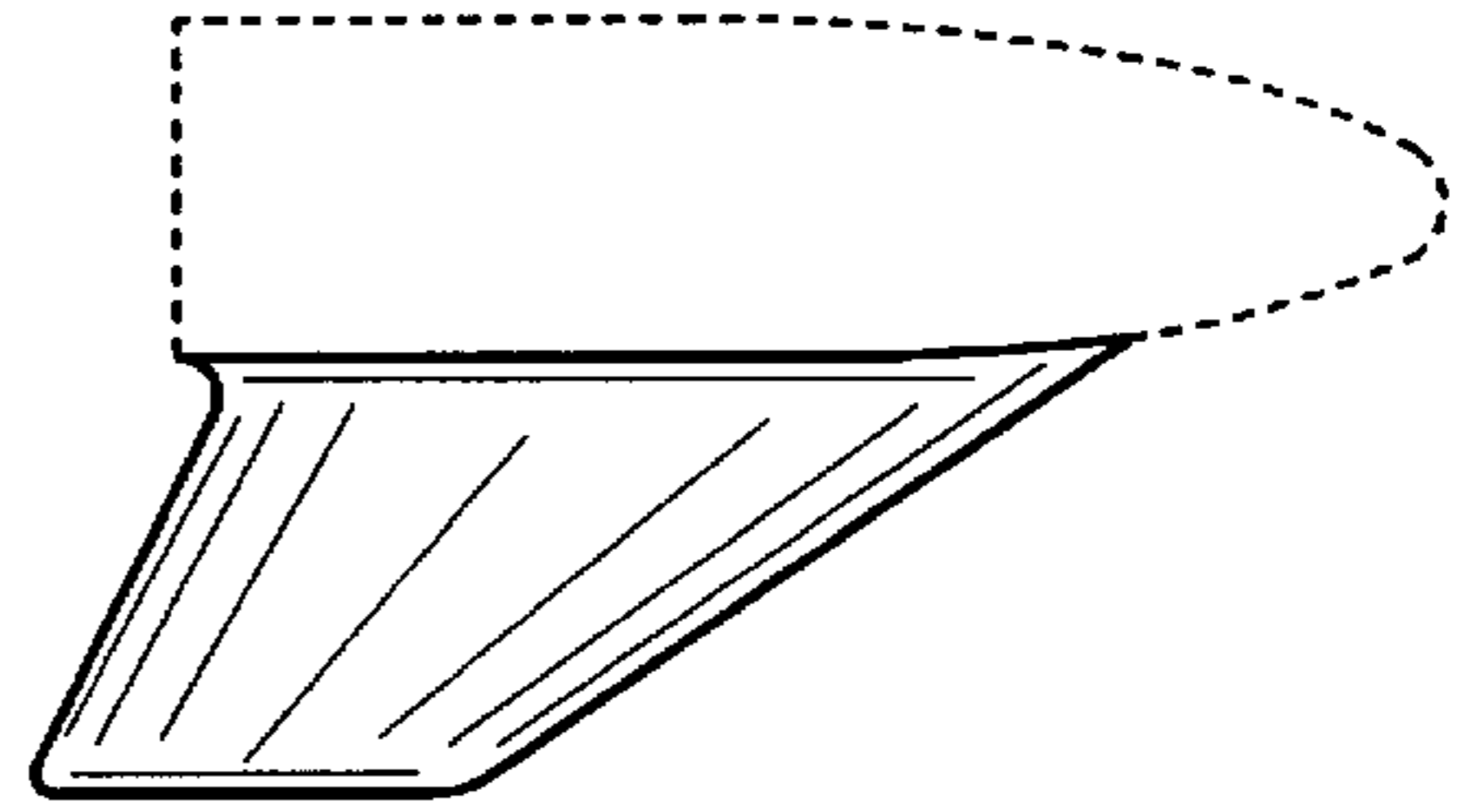

FIG. 3

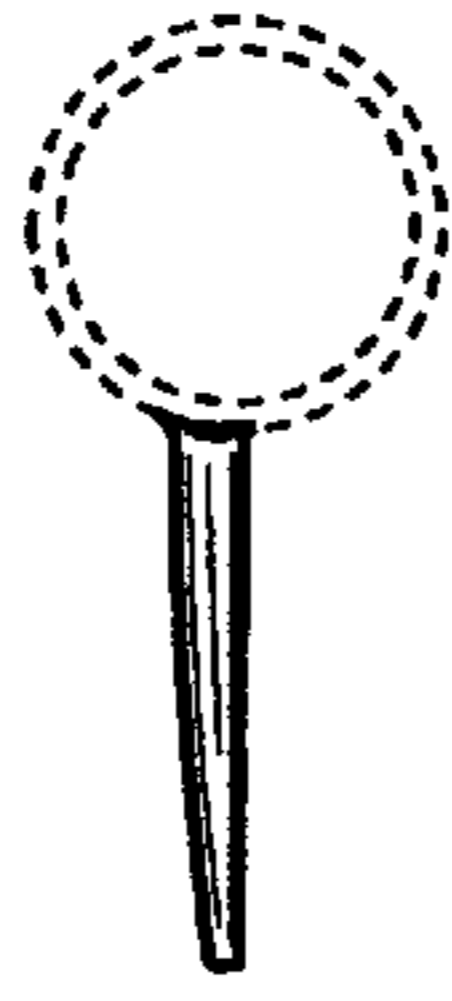

FIG. 4

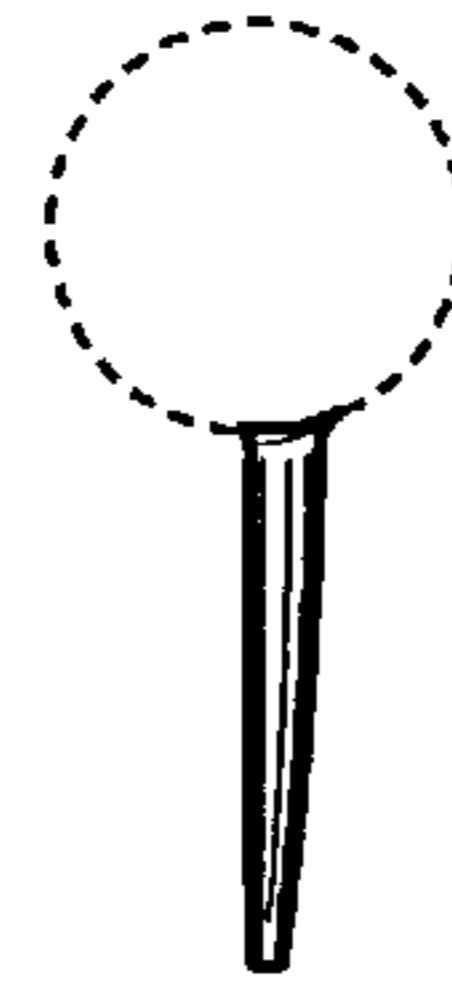

FIG. 5

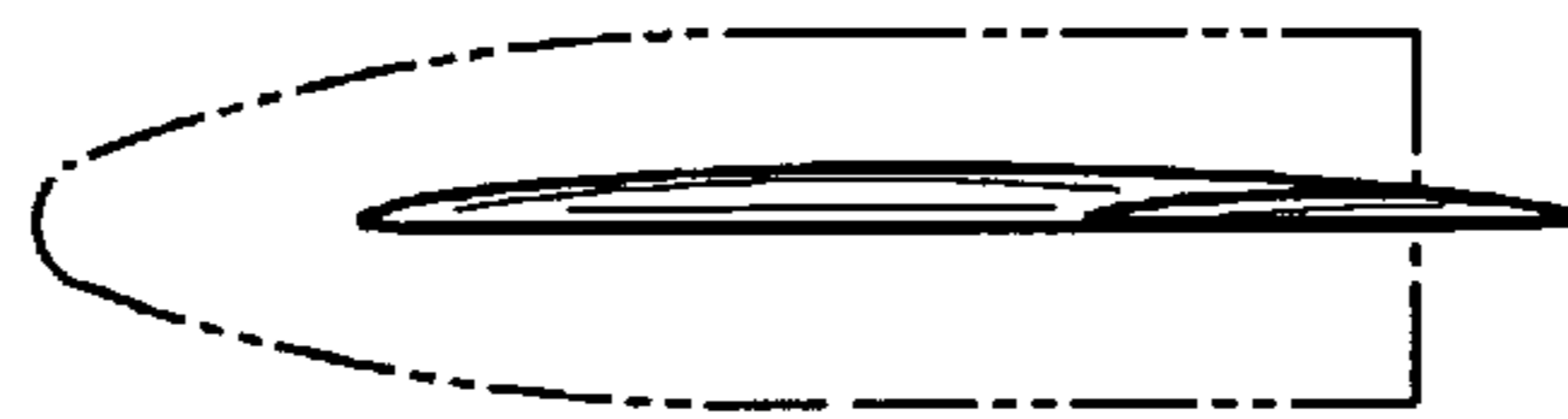

FIG. 6

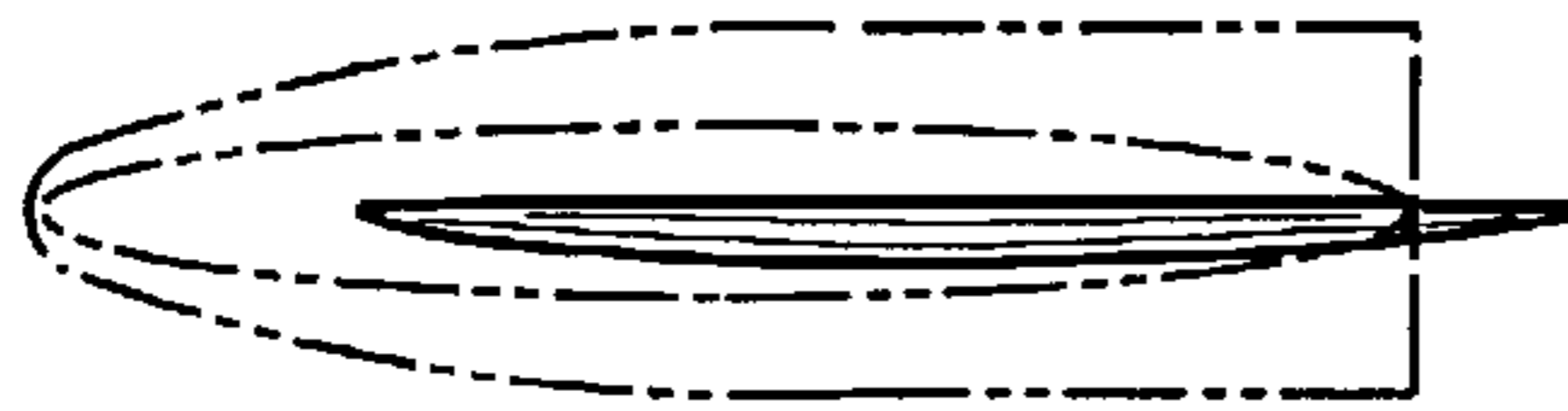

FIG. 7