



US00D422960S

# United States Patent [19] Henry

[11] **Patent Number: Des. 422,960**

[45] **Date of Patent: \*\* \*Apr. 18, 2000**

[54] **WHEEL CHOCK**

[76] Inventor: **Stephen K. Henry**, 3825 Northbrook Dr., #F, Boulder, Colo. 80302

[\*] Notice: This patent is subject to a terminal disclaimer.

[\*\*] Term: **14 Years**

[21] Appl. No.: **29/105,078**

[22] Filed: **May 17, 1999**

### Related U.S. Application Data

[63] Continuation-in-part of application No. 29/066,614, Feb. 13, 1997, Pat. No. Des. 402,616.

[51] **LOC (6) Cl.** ..... **12-06**

[52] **U.S. Cl.** ..... **D12/217**

[58] **Field of Search** ..... D12/114, 120, D12/217; 188/4 R, 32; 224/524; 267/139, 140; 280/293

### [56] References Cited

#### U.S. PATENT DOCUMENTS

D. 338,651 8/1993 Herron ..... D12/217

D. 402,616	12/1998	Henry	.....	D12/217
2,011,469	8/1935	Brueggemann	.....	188/32
2,992,704	7/1961	Showaker et al.	.....	188/32
3,317,006	5/1967	Patterson	.....	188/32

*Primary Examiner*—Robert M. Spear  
*Attorney, Agent, or Firm*—Dorr, Carson, Sloan, & Birney, P.C.

### [57] CLAIM

The ornamental design for a wheel chock, as shown and described.

### DESCRIPTION

FIG. 1 is a front perspective view of a wheel chock showing my new design;  
FIG. 2 is a front elevational view of the wheel chock with the rear elevational view being a mirror image of FIG. 2.  
FIG. 3 is a top plan view of the wheel chock.  
FIG. 4 is left side elevational view of the wheel chock.  
FIG. 5 is a right side elevational view of the wheel chock; and,  
FIG. 6 is a bottom plan view of the wheel chock.  
The surface(s) or portion(s) of the article not shown in the drawing or described in the specification form(s) no part of the claimed design.

**1 Claim, 2 Drawing Sheets**

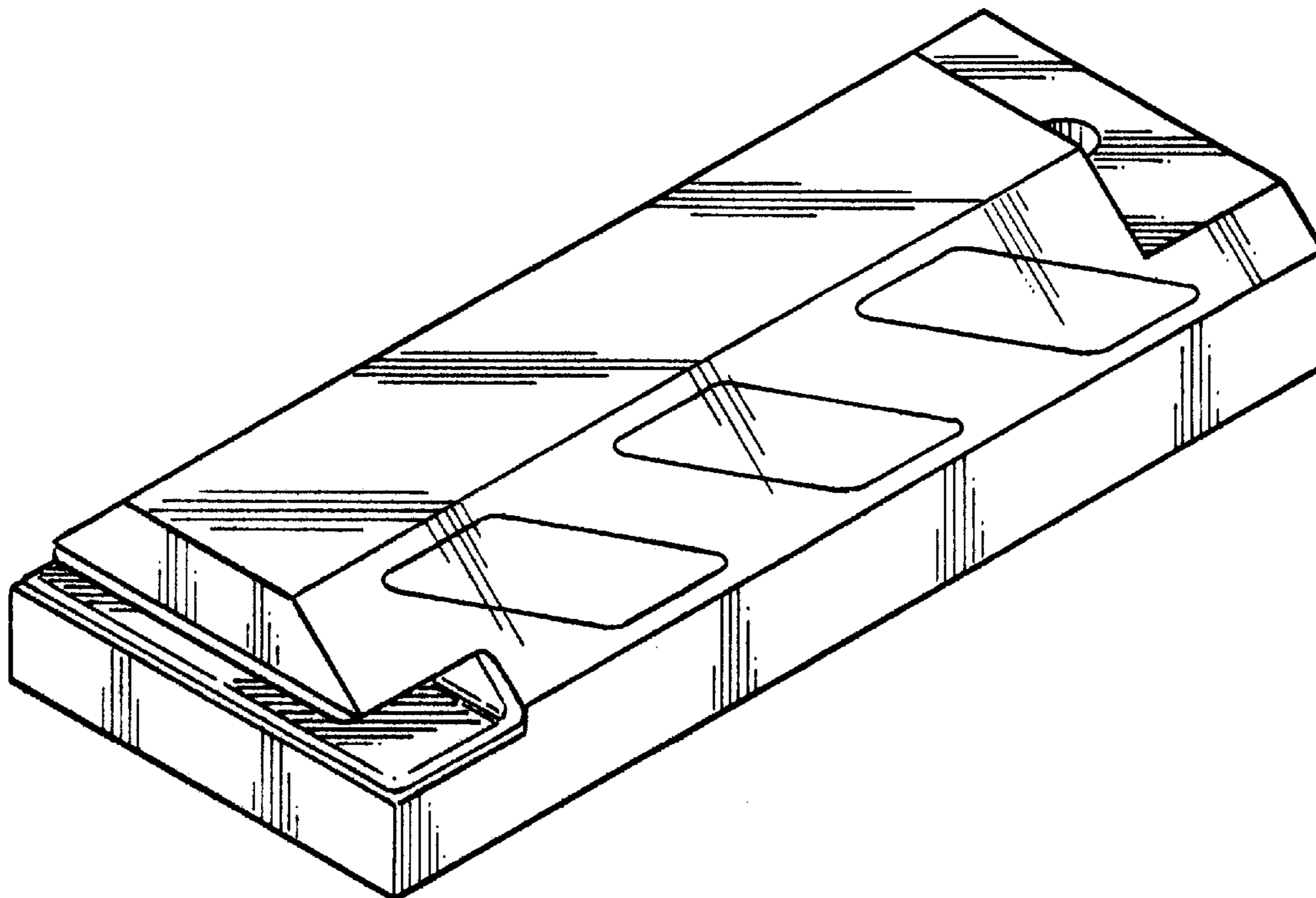

Fig. 1

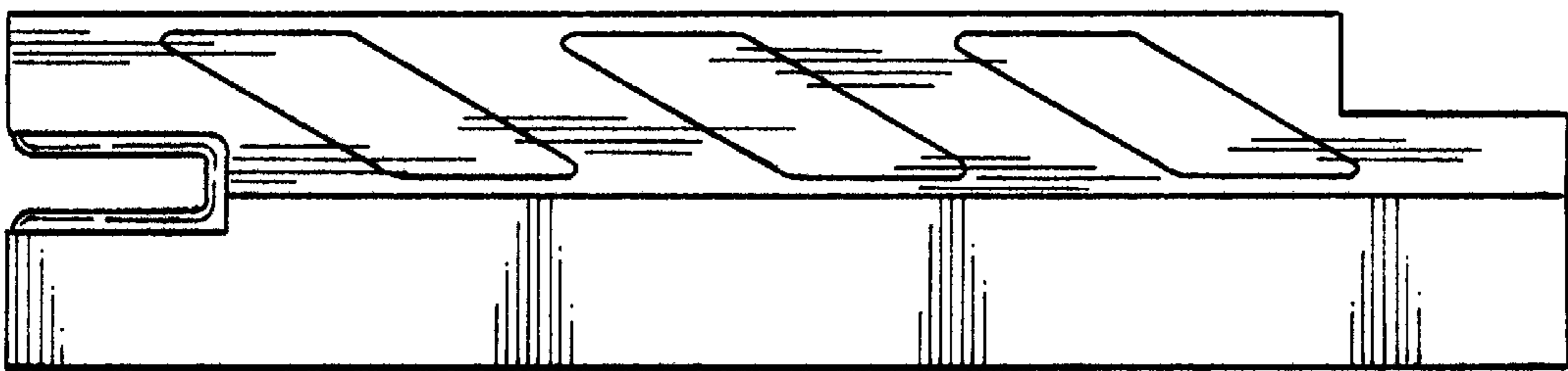
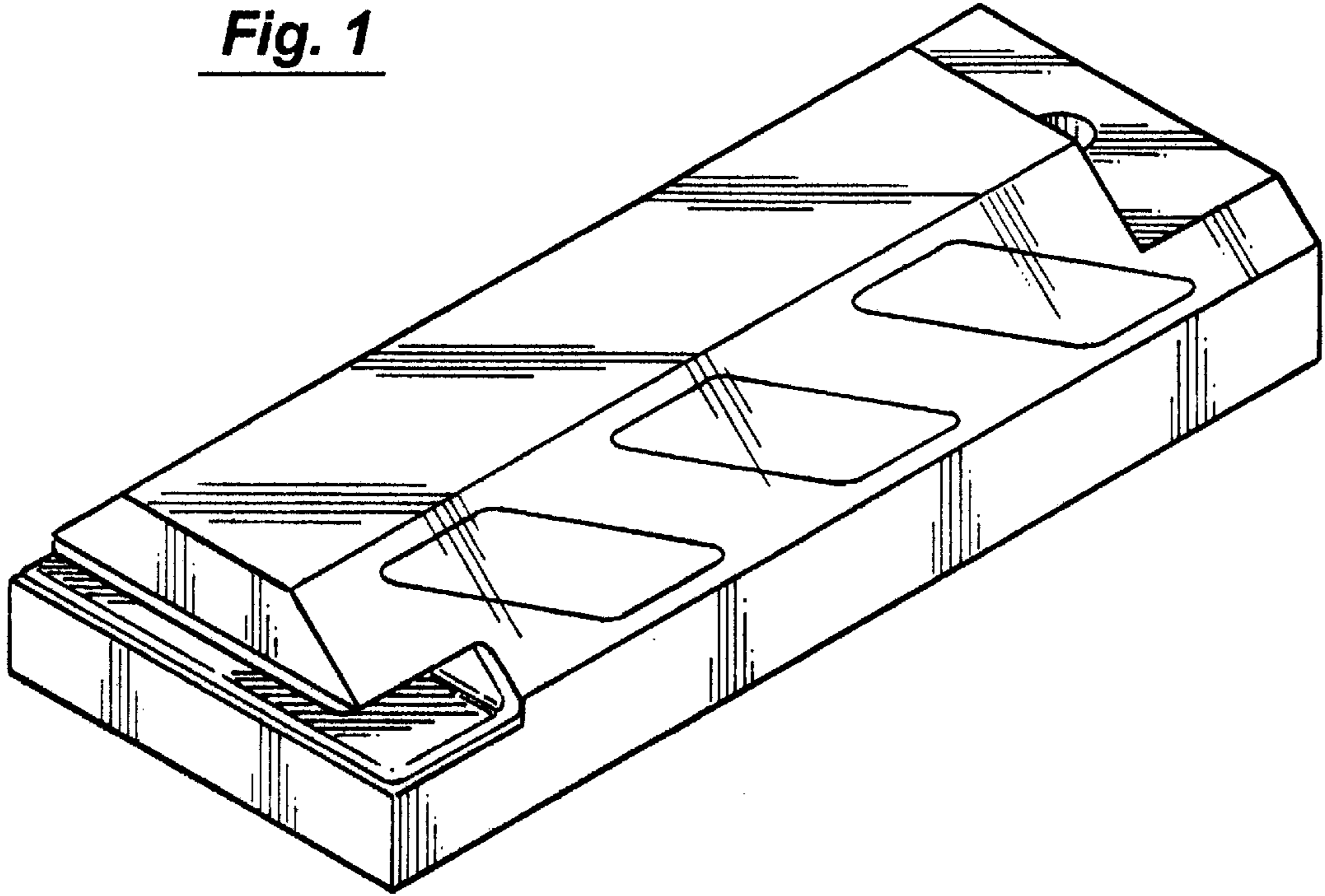

Fig. 2

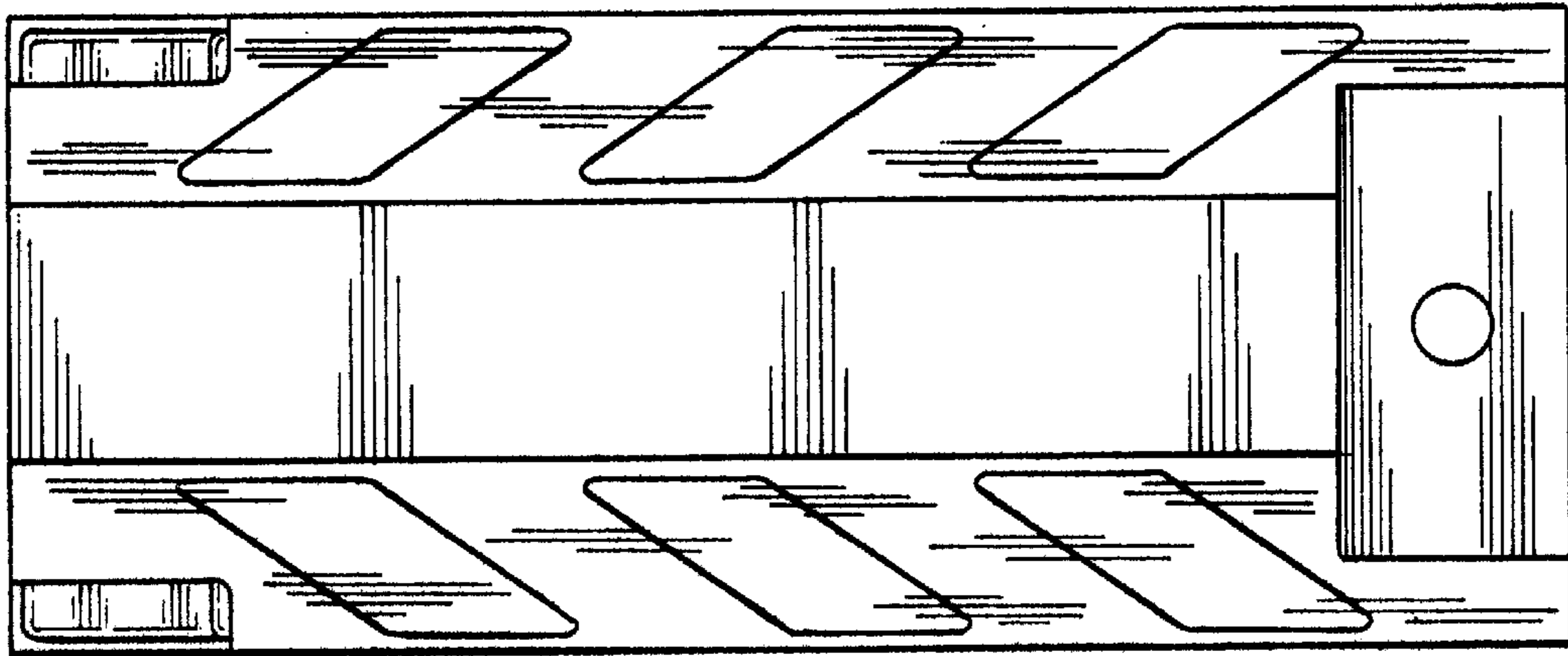

Fig. 3

Fig. 4

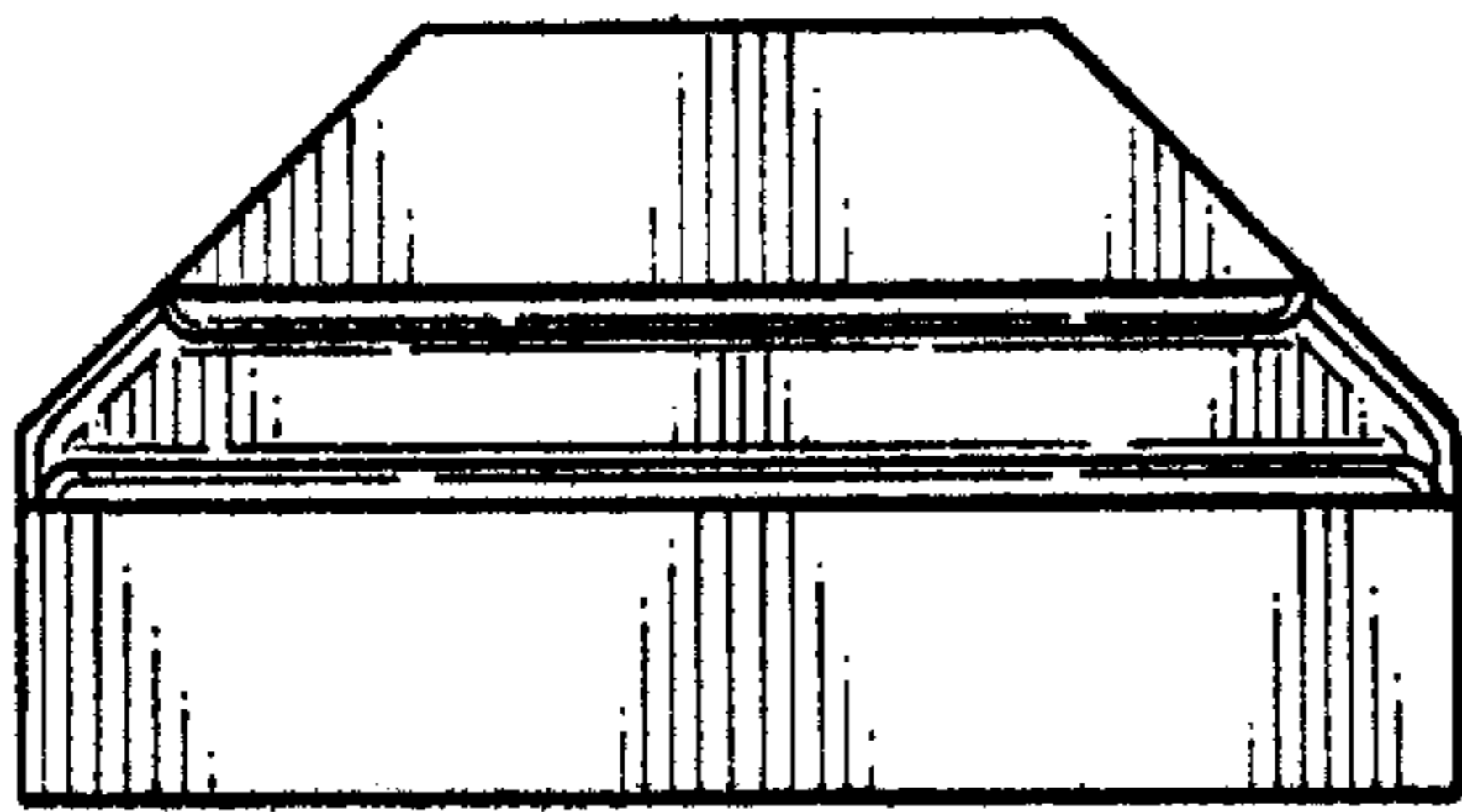

Fig. 5

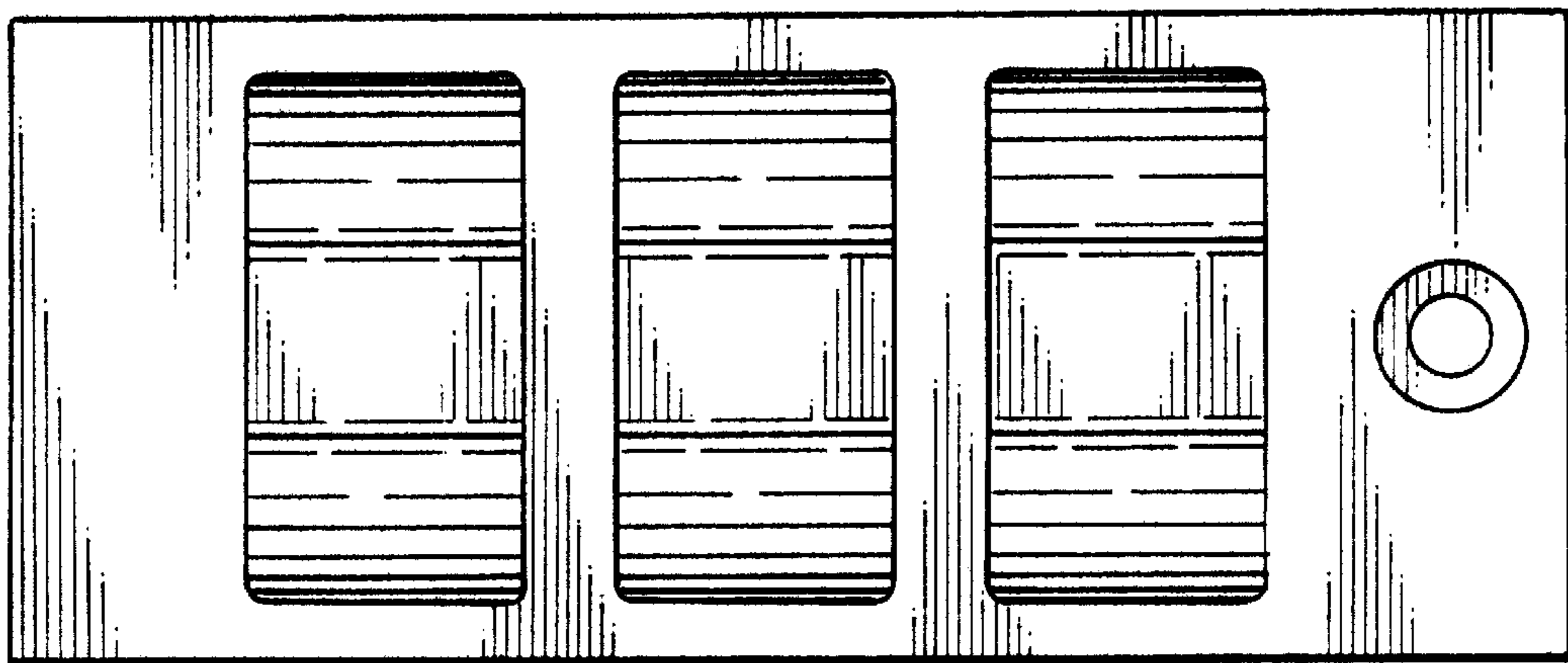
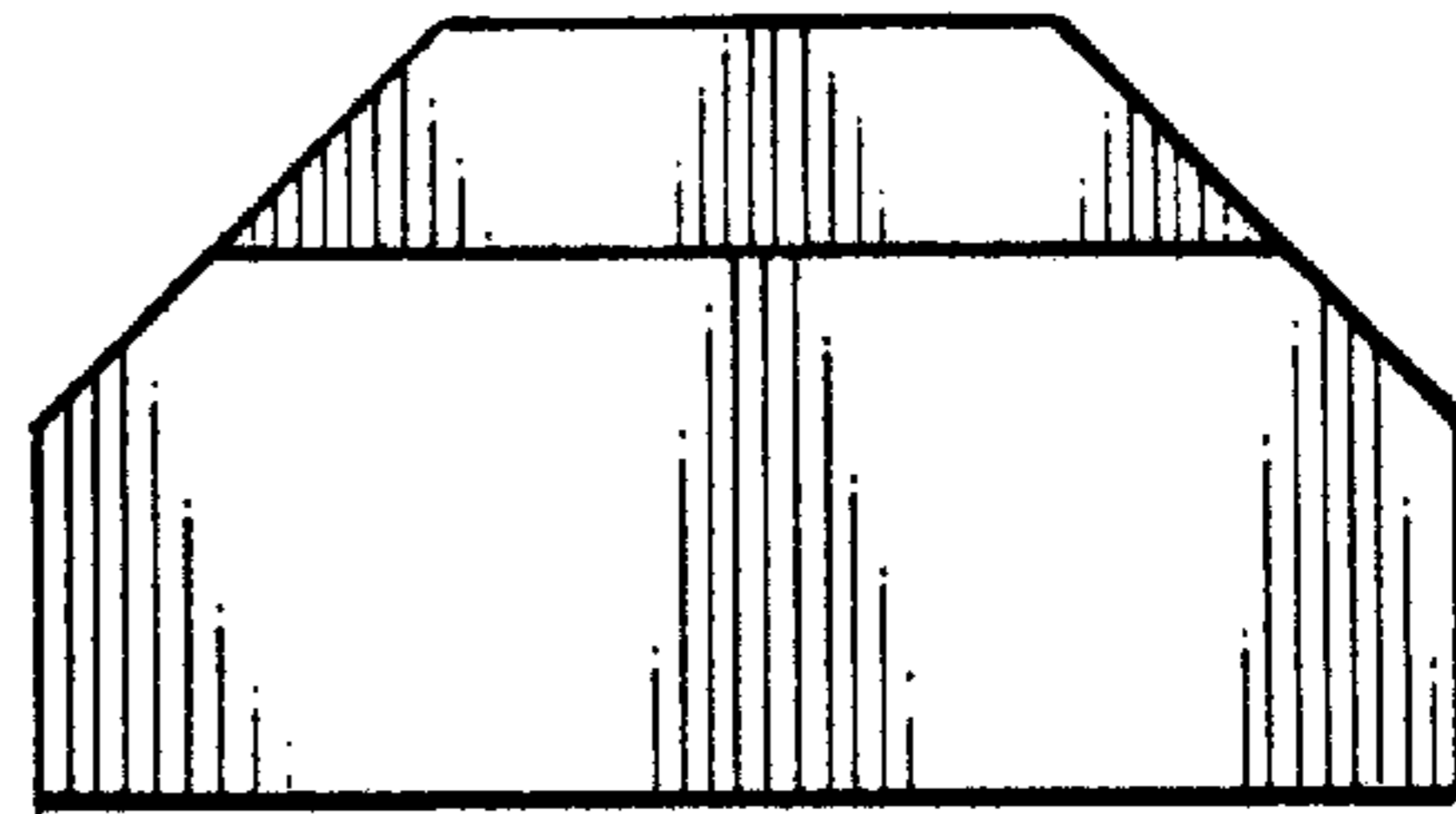

Fig. 6