



US00D422943S

United States Patent [19]

[11] Patent Number: Des. 422,943

Sims et al.

[45] Date of Patent: ** Apr. 18, 2000

[54] AUTOMOBILE

[75] Inventors: Daniel Jerome Sims, Lake Forest;
Roger Zrimec, Laguna Beach, both of Calif.

[73] Assignee: Mitsubishi Jidosha Kogyo Kabushiki Kaisha, Tokyo, Japan

[**] Term: 14 Years

[21] Appl. No.: 29/100,579

[22] Filed: Feb. 12, 1999

[51] LOC (6) Cl. 12-08

[52] U.S. Cl. D12/92

[58] Field of Search D12/90-92; 296/185

[56] References Cited

U.S. PATENT DOCUMENTS

D. 350,086	8/1994	Kong et al.	D12/92
D. 357,887	5/1995	Sacco et al.	D12/92
D. 361,046	8/1995	Watkins et al.	D12/92
D. 406,551	3/1999	Nesbitt et al.	D12/92

Primary Examiner—Melody N. Brown

[57] CLAIM

The ornamental design for an automobile, as shown and described.

DESCRIPTION

FIG. 1 is a front perspective view of an automobile showing

our new design;

FIG. 2 is a rear perspective view thereof;

FIG. 3 is a front elevation view thereof;

FIG. 4 is a rear elevation view thereof;

FIG. 5 is a right side elevation view thereof;

FIG. 6 is a top plan view thereof;

FIG. 7 is a front perspective view of second embodiment of an automobile showing our new design;

FIG. 8 is a rear perspective view of the automobile of FIG. 7;

FIG. 9 is a front elevation view of the automobile of FIG. 7;

FIG. 10 is a rear elevation view of the automobile of FIG. 7;

FIG. 11 is a right side elevation view of the automobile of FIG. 7;

FIG. 12 is a top plan view of the automobile of FIG. 7; and,

FIG. 13 is a right side elevation view of the automobile of FIG. 7 with a roof up.

A left side elevation view of the automobile of FIG. 1 and a left side elevation view of the automobile of FIG. 7 have been omitted since they are symmetrical to FIGS. 5 and 11, respectively.

The broken lines showing of environmental structure in FIGS. 1, 2, 3, 4, 5, 7, 8, 9, 10, 11, and 12 of the drawing are for illustrative purposes only and form no part of the claimed design.

1 Claim, 11 Drawing Sheets

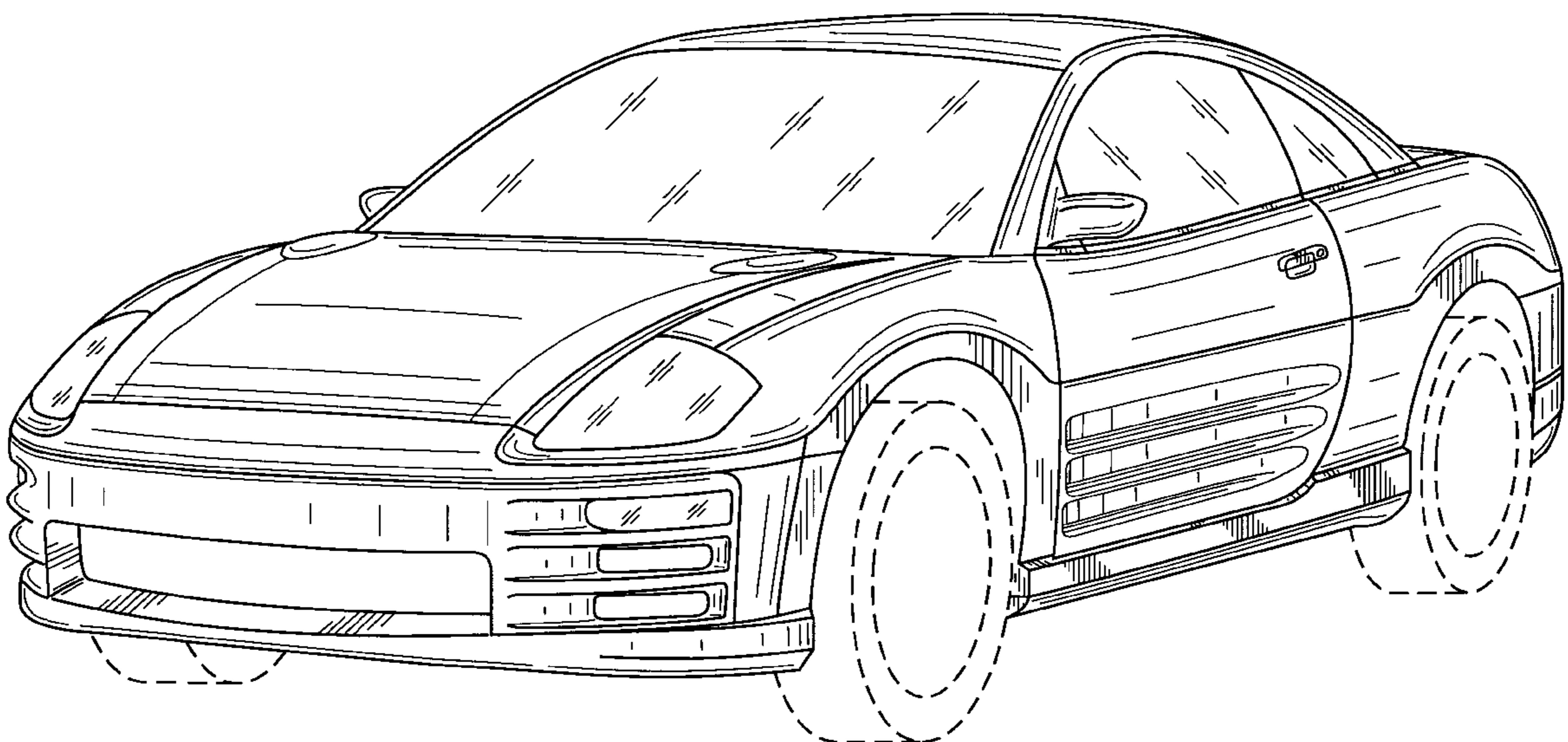

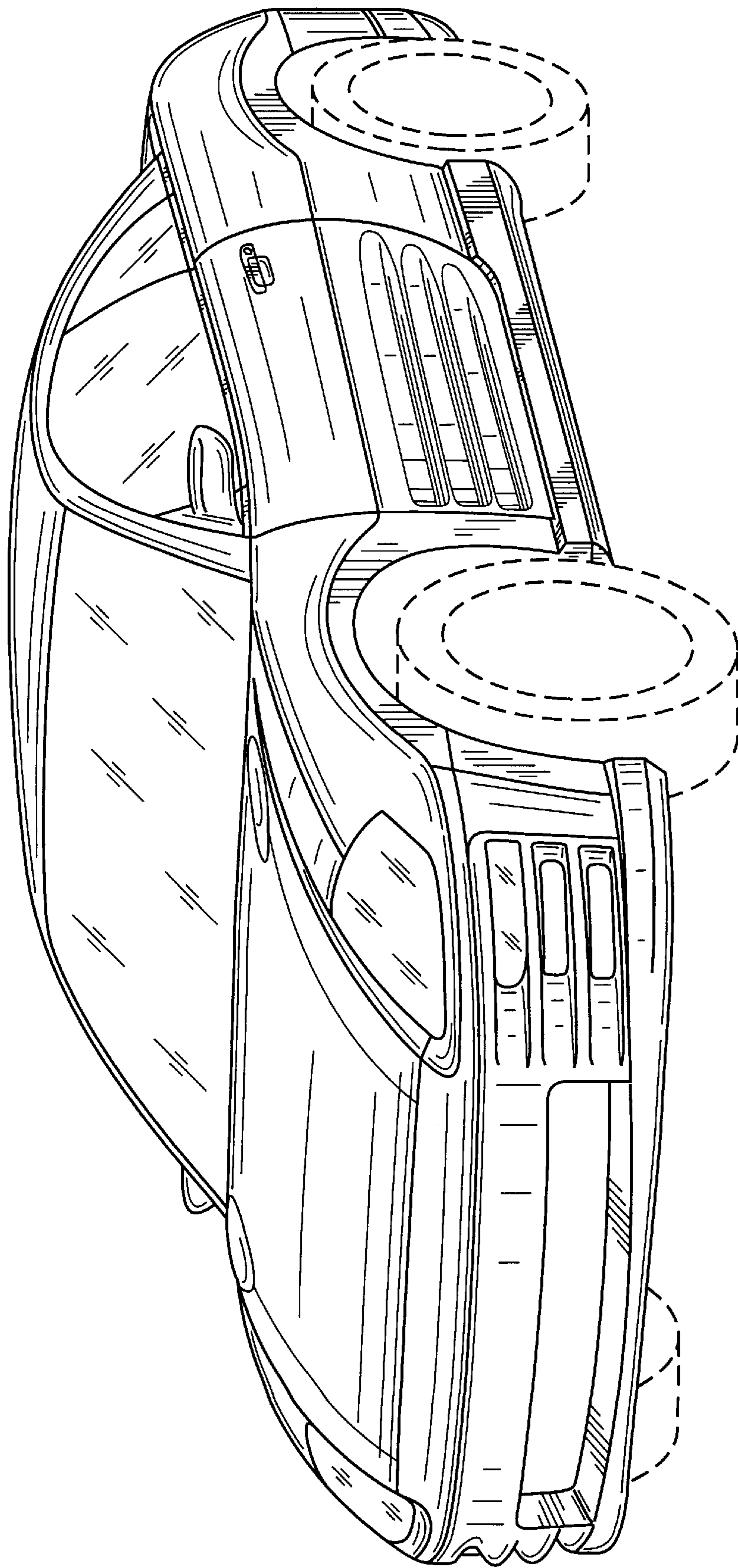

FIG. 1

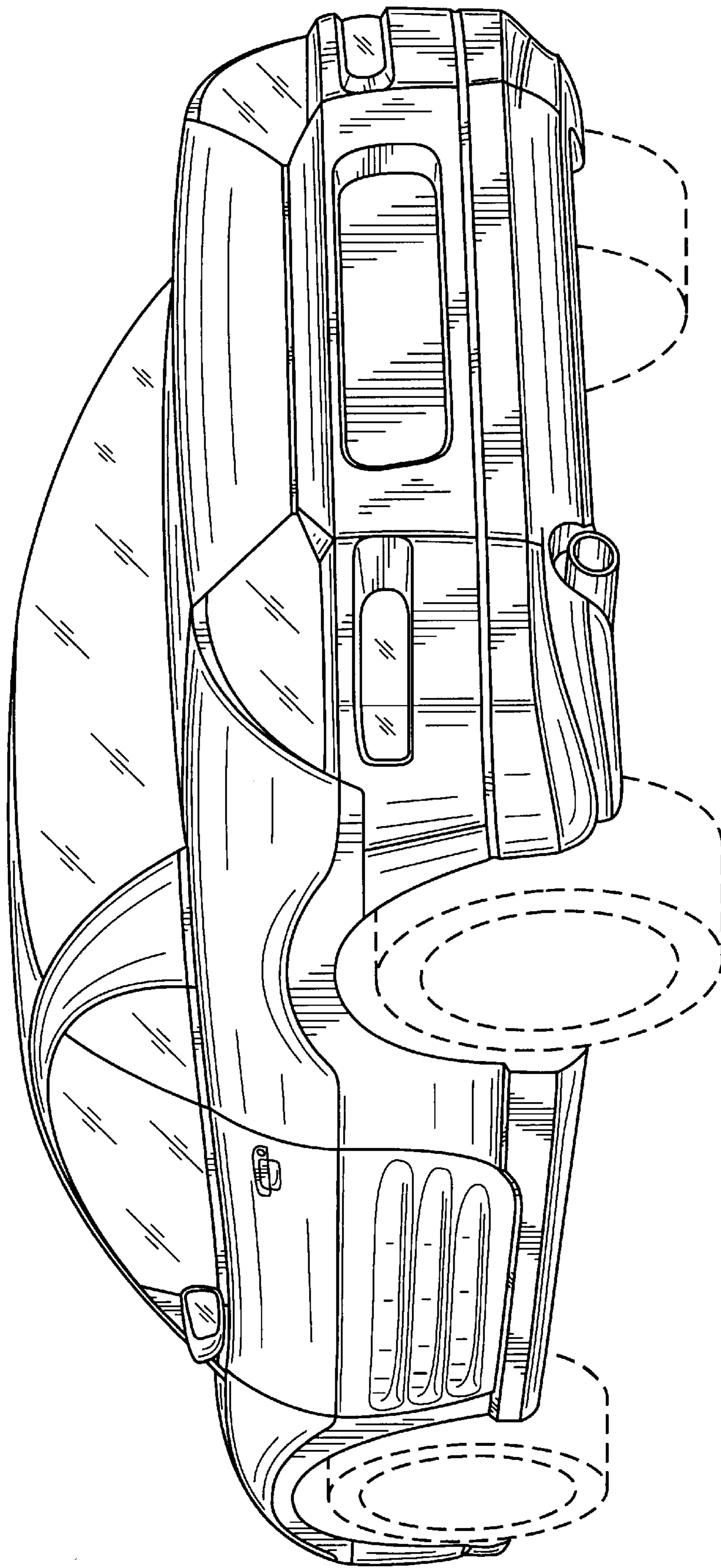

FIG. 2

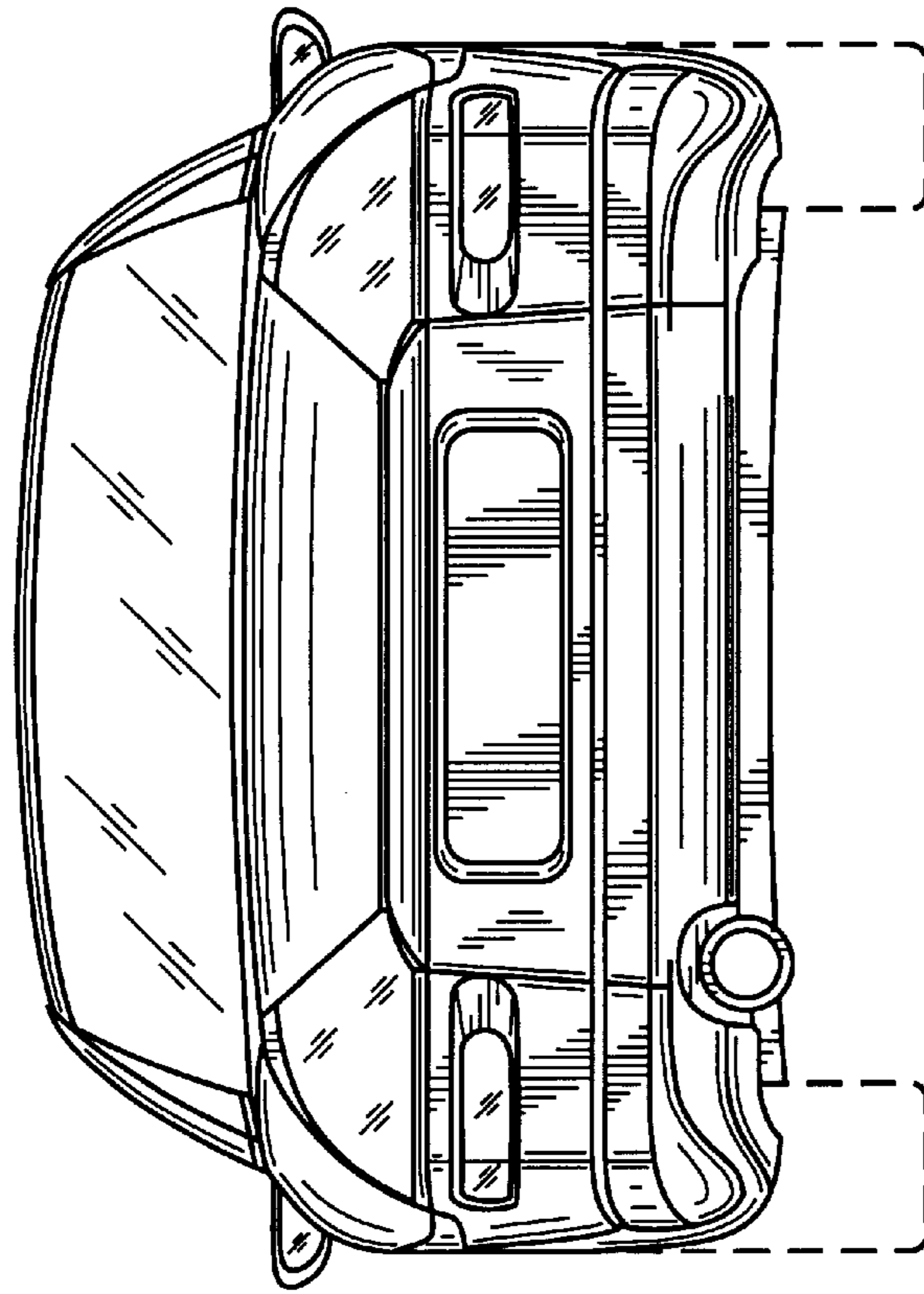

FIG. 4

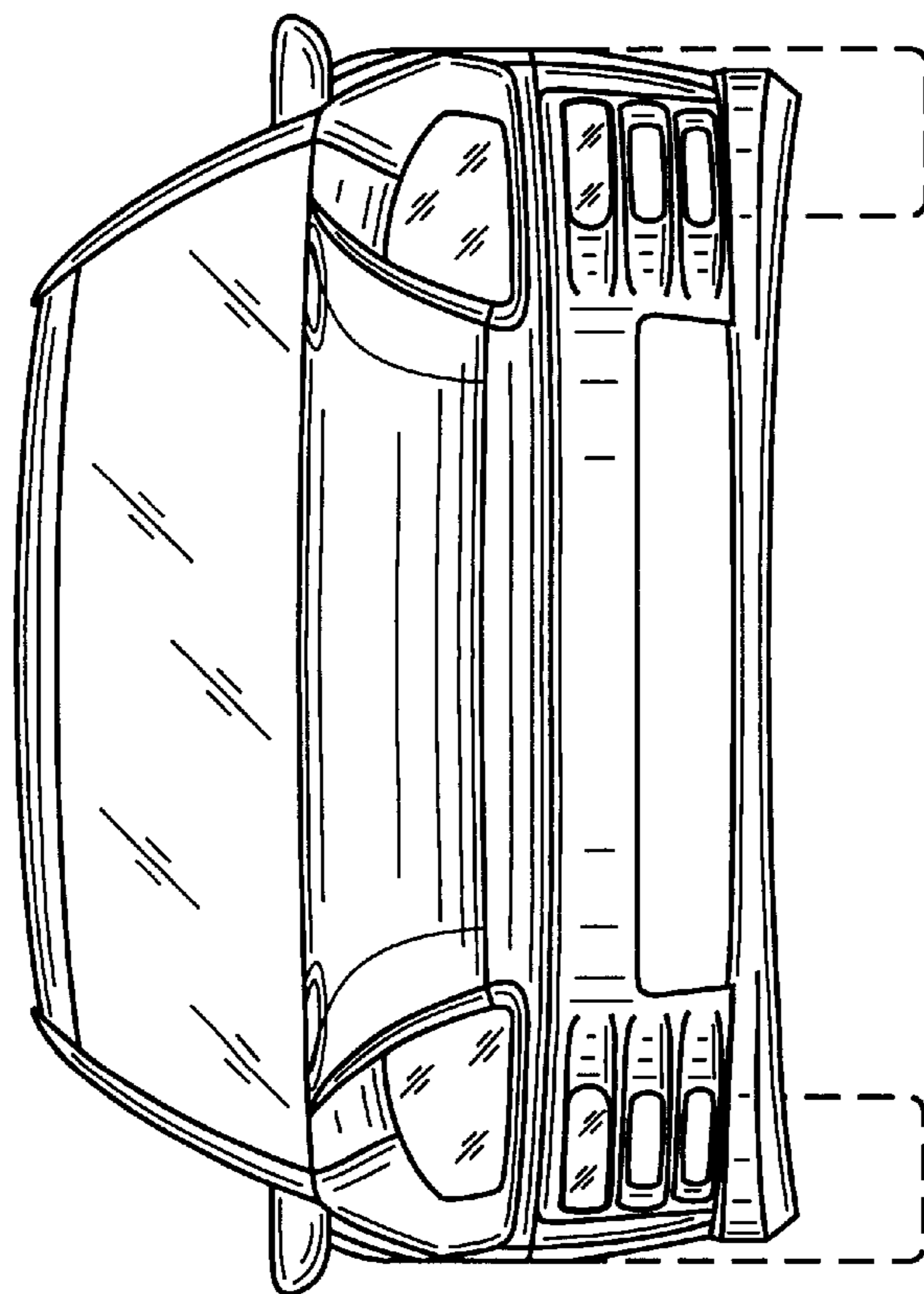

FIG. 3

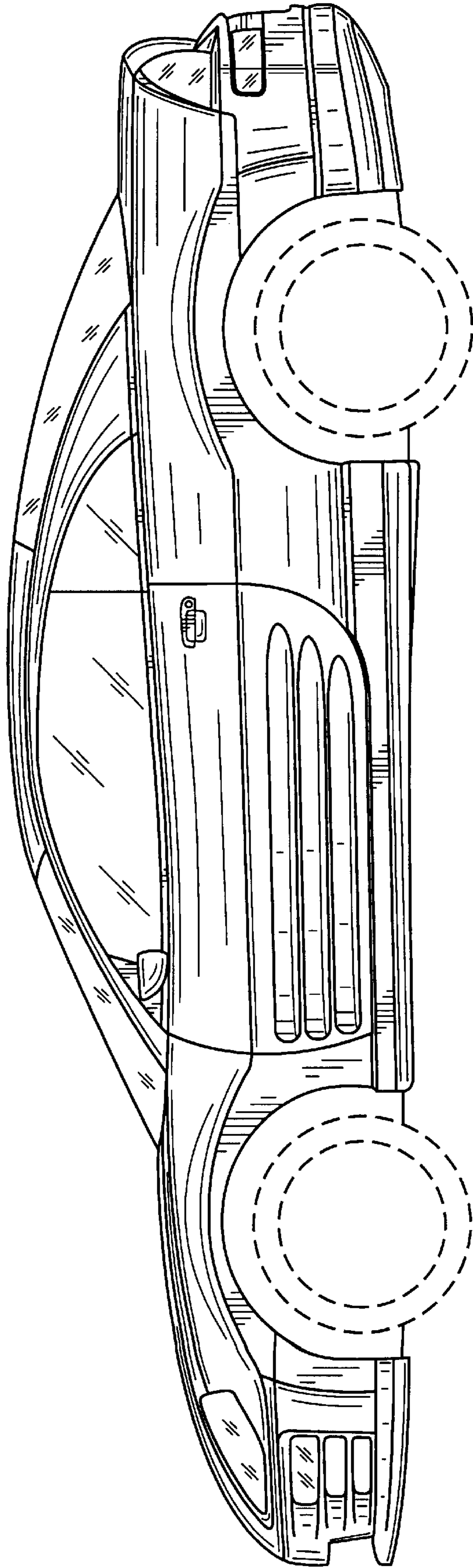

FIG. 5

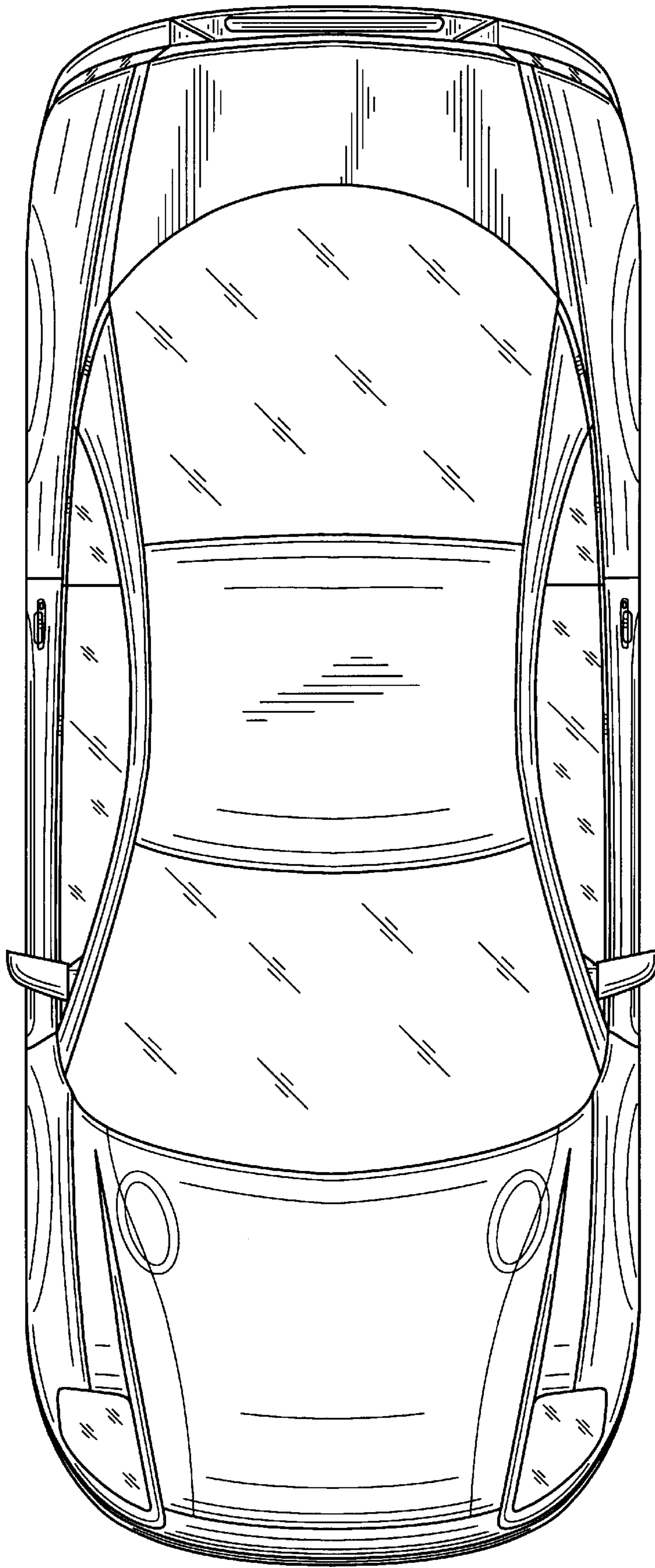

FIG. 6

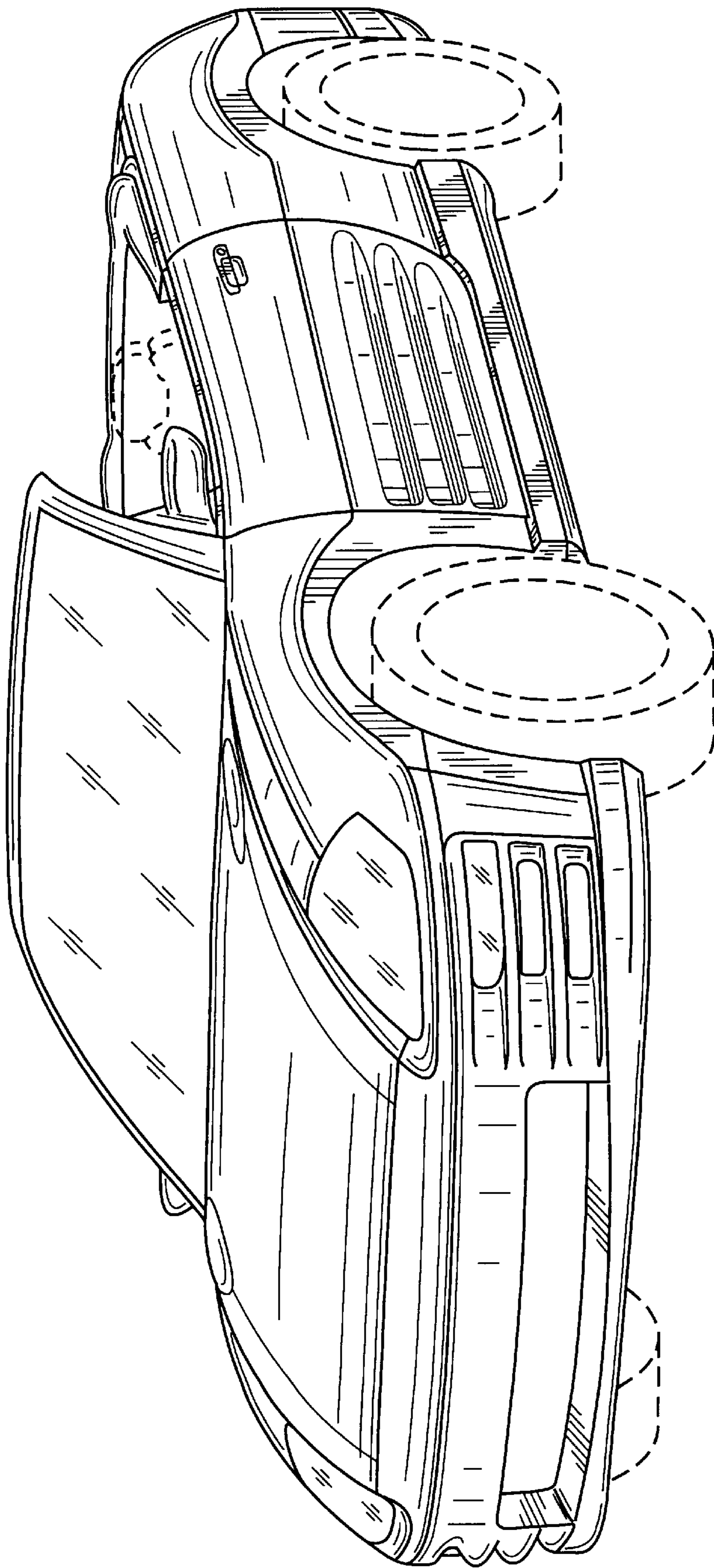

FIG. 7

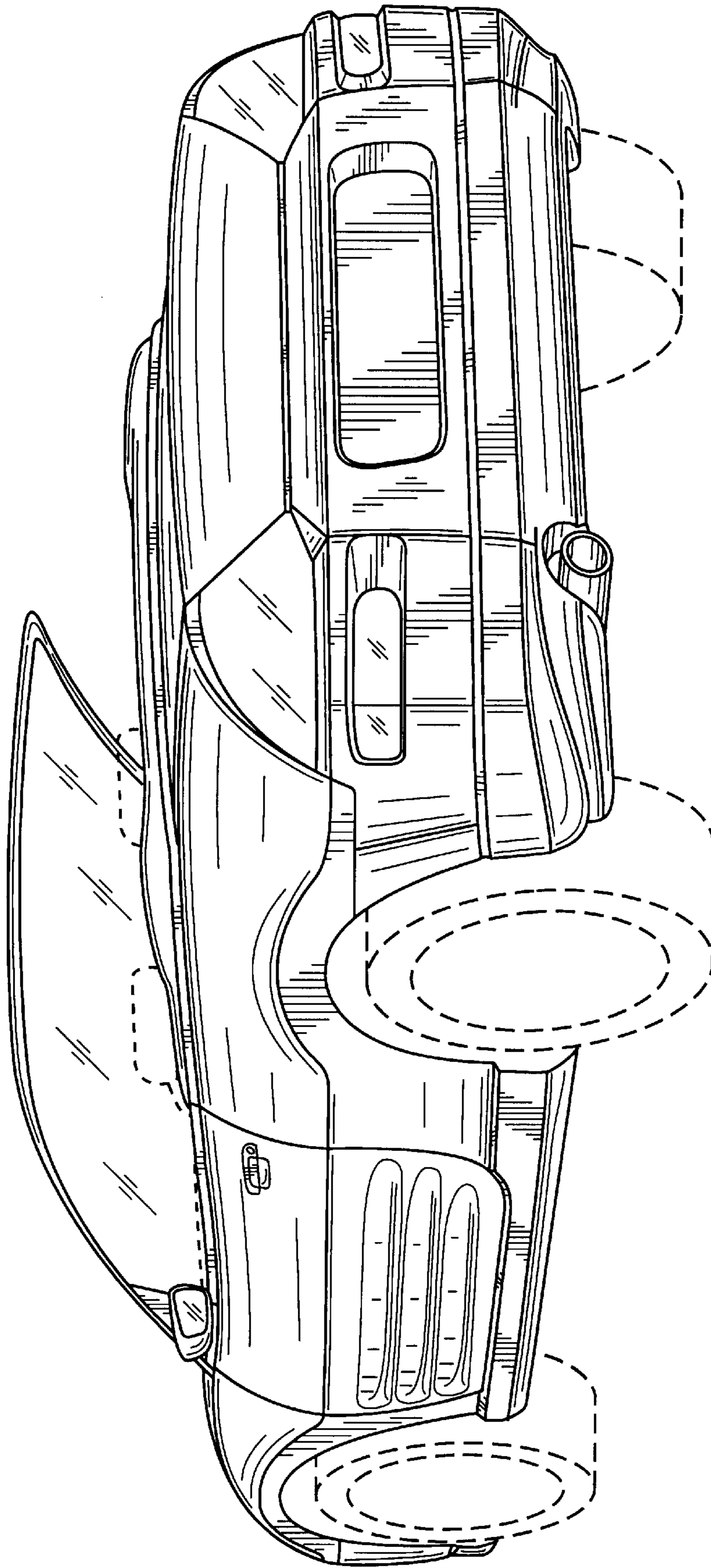

FIG. 8

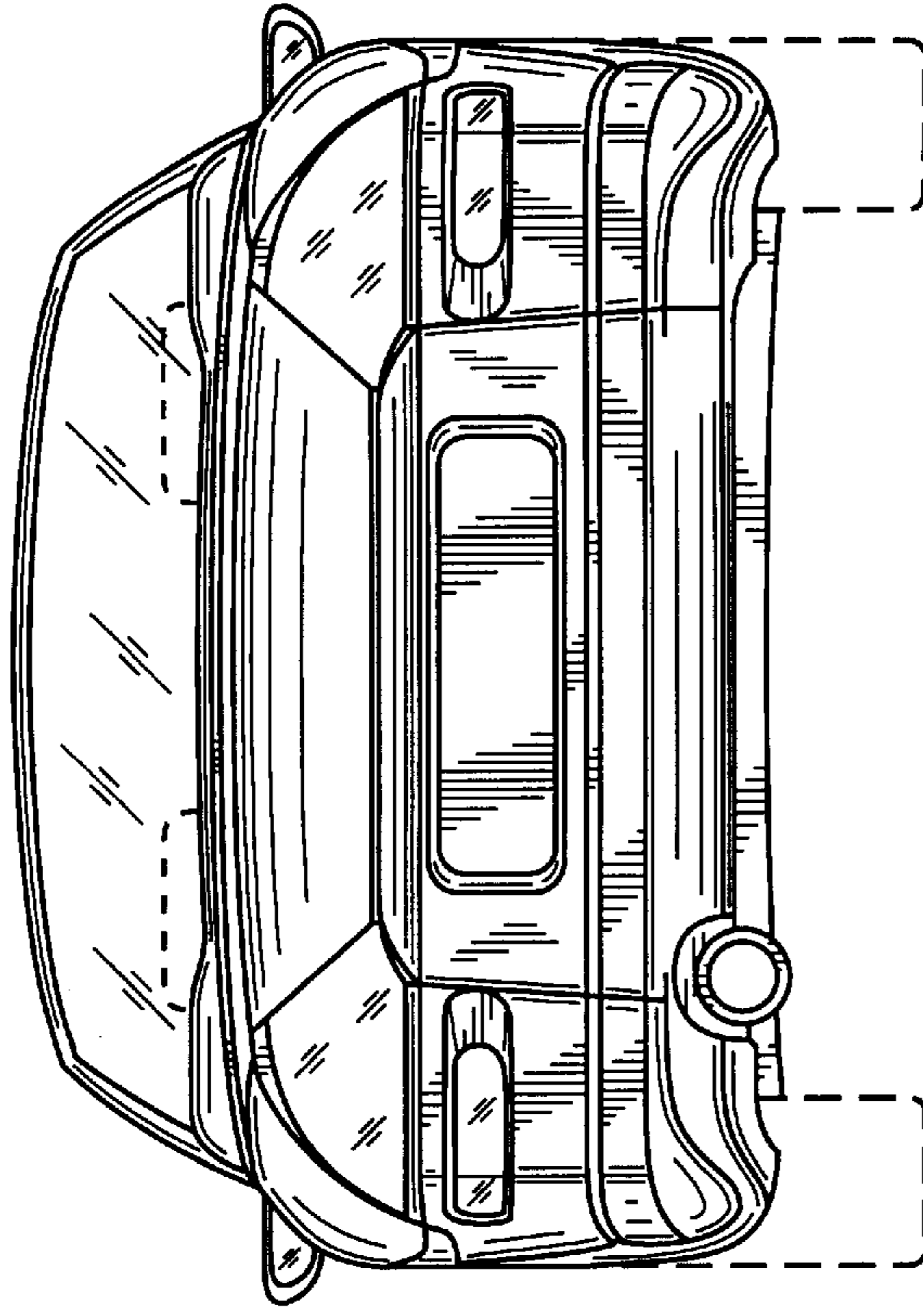

FIG. 9

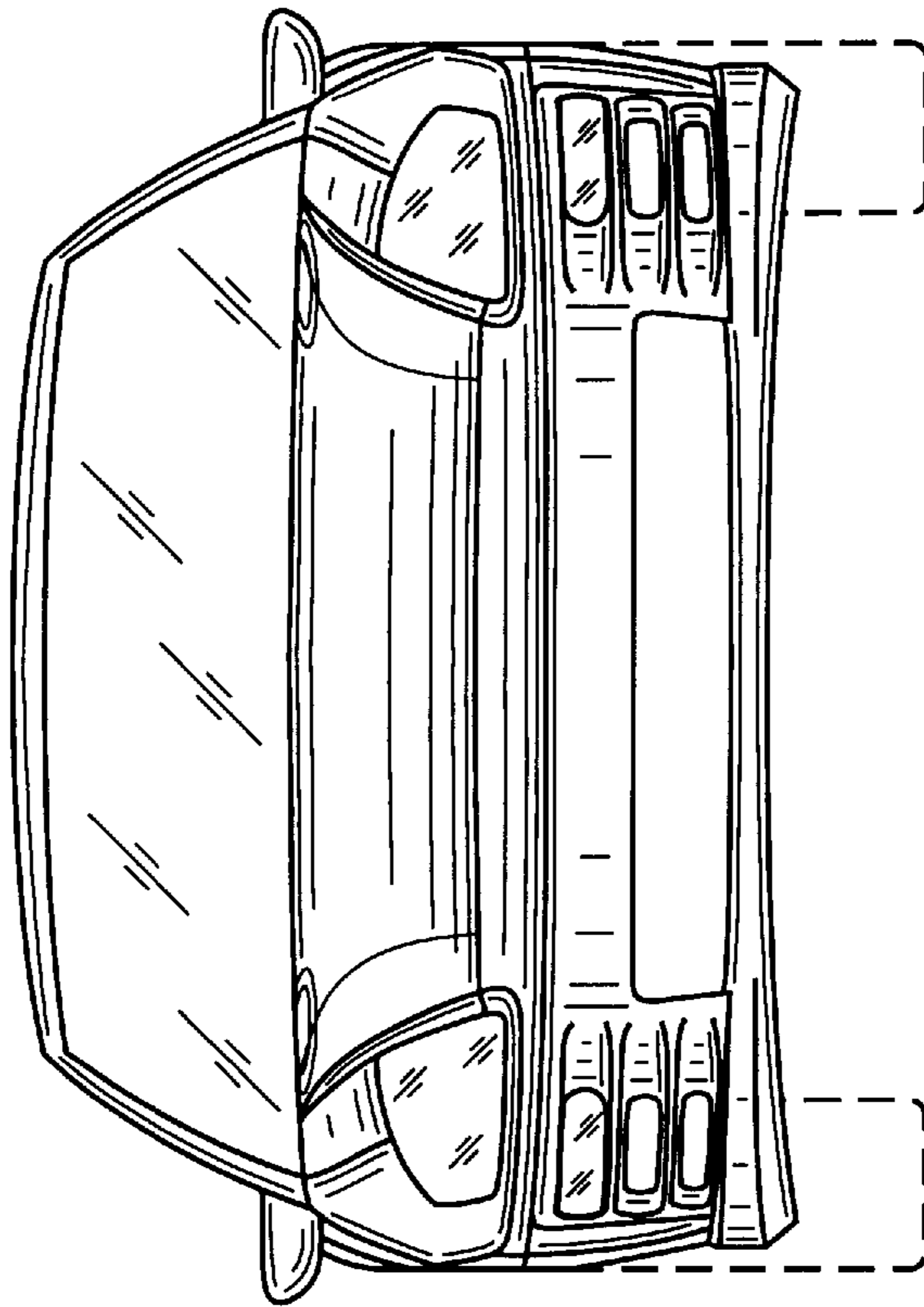

FIG. 10

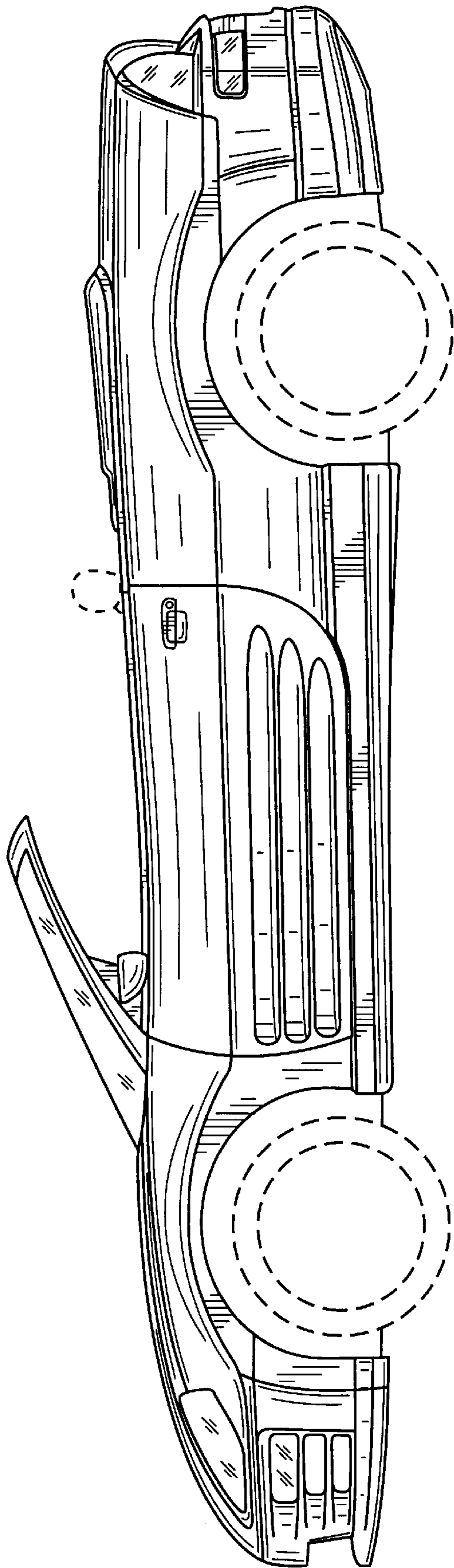

FIG. 11

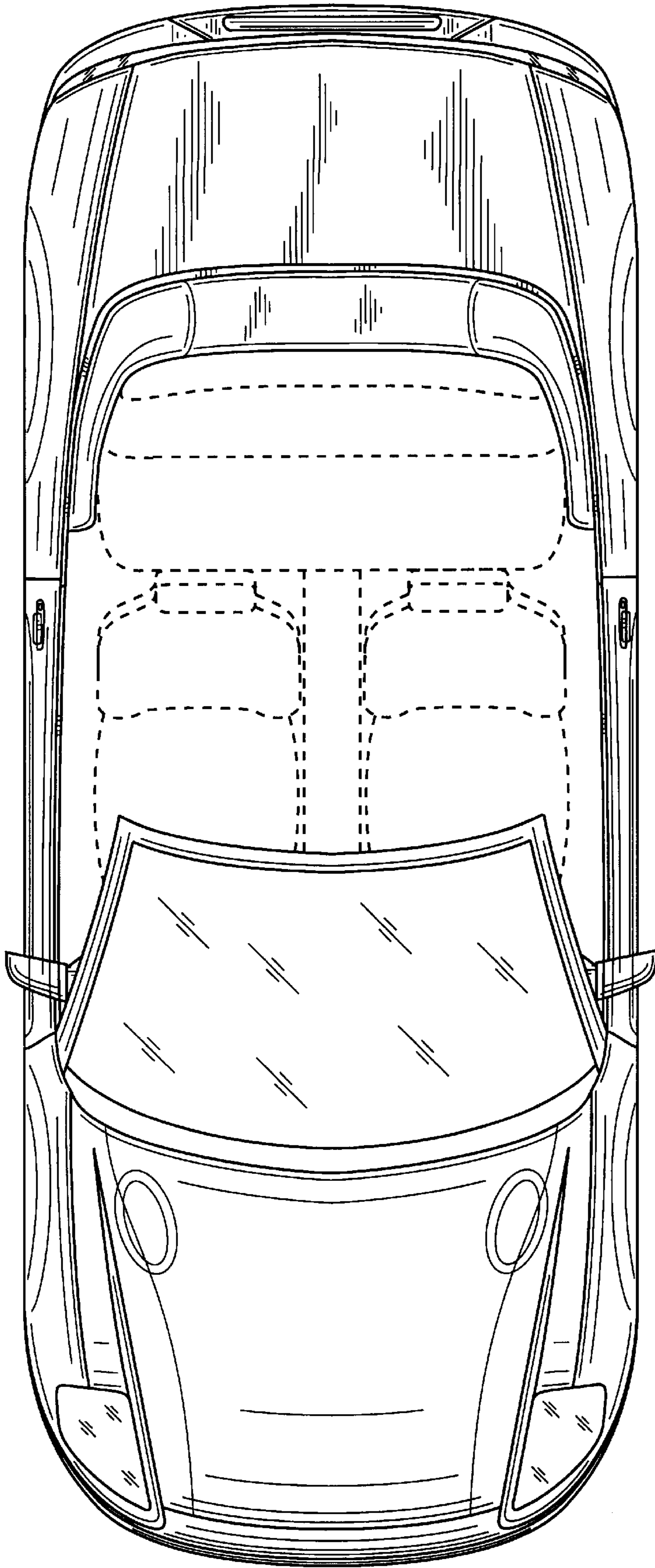

FIG. 12

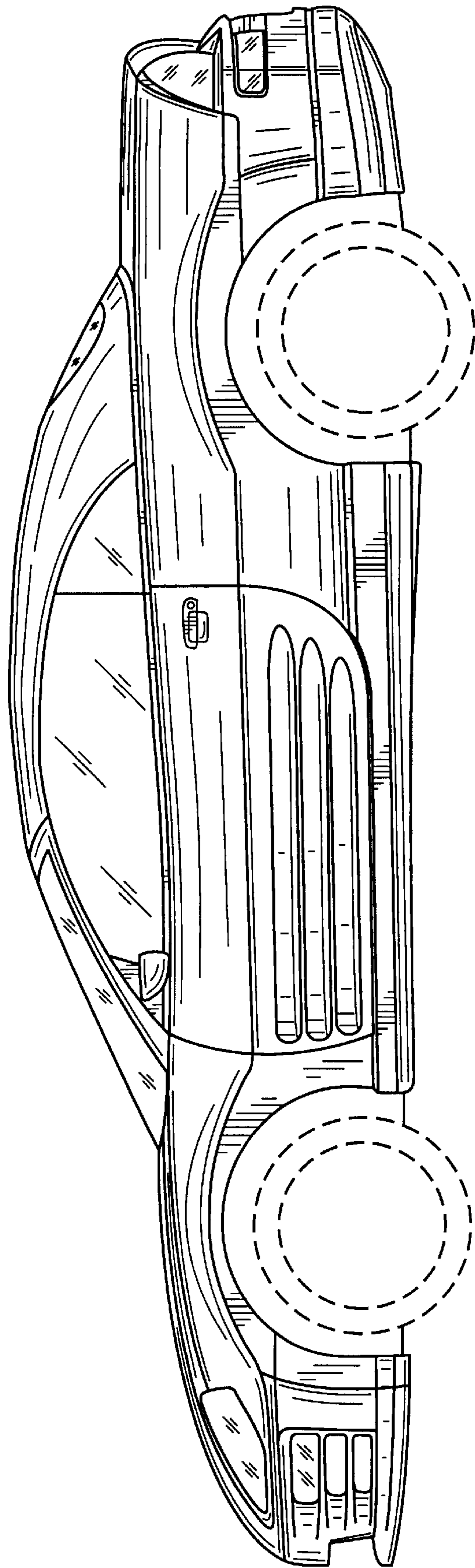

FIG. 13