



US00D422941S

United States Patent [19]
Sigurosson

[11] **Patent Number: Des. 422,941**

[45] **Date of Patent: ** Apr. 18, 2000**

[54] **MOTOR VEHICLE BODY**

[76] Inventor: **Steinn Sigurosson**, Steinaseli 1, 109 Reykjavik, Iceland

[**] Term: **14 Years**

[21] Appl. No.: **29/095,528**

[22] Filed: **Oct. 26, 1998**

[30] **Foreign Application Priority Data**

Jun. 11, 1998 [IS] Iceland 139

[51] **LOC (6) Cl.** **12-08**

[52] **U.S. Cl.** **D12/91**

[58] **Field of Search** D12/90-92, 86, D12/14, 12; 296/185

[56] **References Cited**

U.S. PATENT DOCUMENTS

- D. 242,696 12/1976 Keyes D12/85
- D. 299,705 2/1989 Carpanelli et al. D12/88
- D. 323,305 1/1992 Smith D12/12
- D. 323,899 2/1992 LaPointe D26/28
- D. 328,880 8/1992 Vysotsky et al. D12/97
- D. 340,208 10/1993 Wolfe et al. D12/87
- D. 346,990 5/1994 Abbott et al. D12/91

- D. 373,330 9/1996 Halajko D12/90
- D. 374,197 10/1996 Axe et al. D12/91
- D. 393,609 4/1998 Kanthak et al. D12/91

Primary Examiner—Melody N. Brown
Attorney, Agent, or Firm—Sofer & Haroun, LLP

[57] **CLAIM**

The ornamental design for a motor vehicle body, as shown and described.

DESCRIPTION

FIG. 1 is a perspective view of a motor vehicle body showing my new design; FIG. 2 is a side view thereof; FIG. 3 is a front view thereof; FIG. 4 is a top view thereof; FIG. 5 is a rear view thereof; and, FIG. 6 is a front view thereof, showing the motor vehicle body with two open doors.

Be it known that I, Steinn Sigurosson, have invented a new, original and ornamental design for a motor vehicle body. The wheels, lights and sideview mirrors, shown in broken lines, are for illustrative purposes only and form no part of the claimed design.

1 Claim, 6 Drawing Sheets

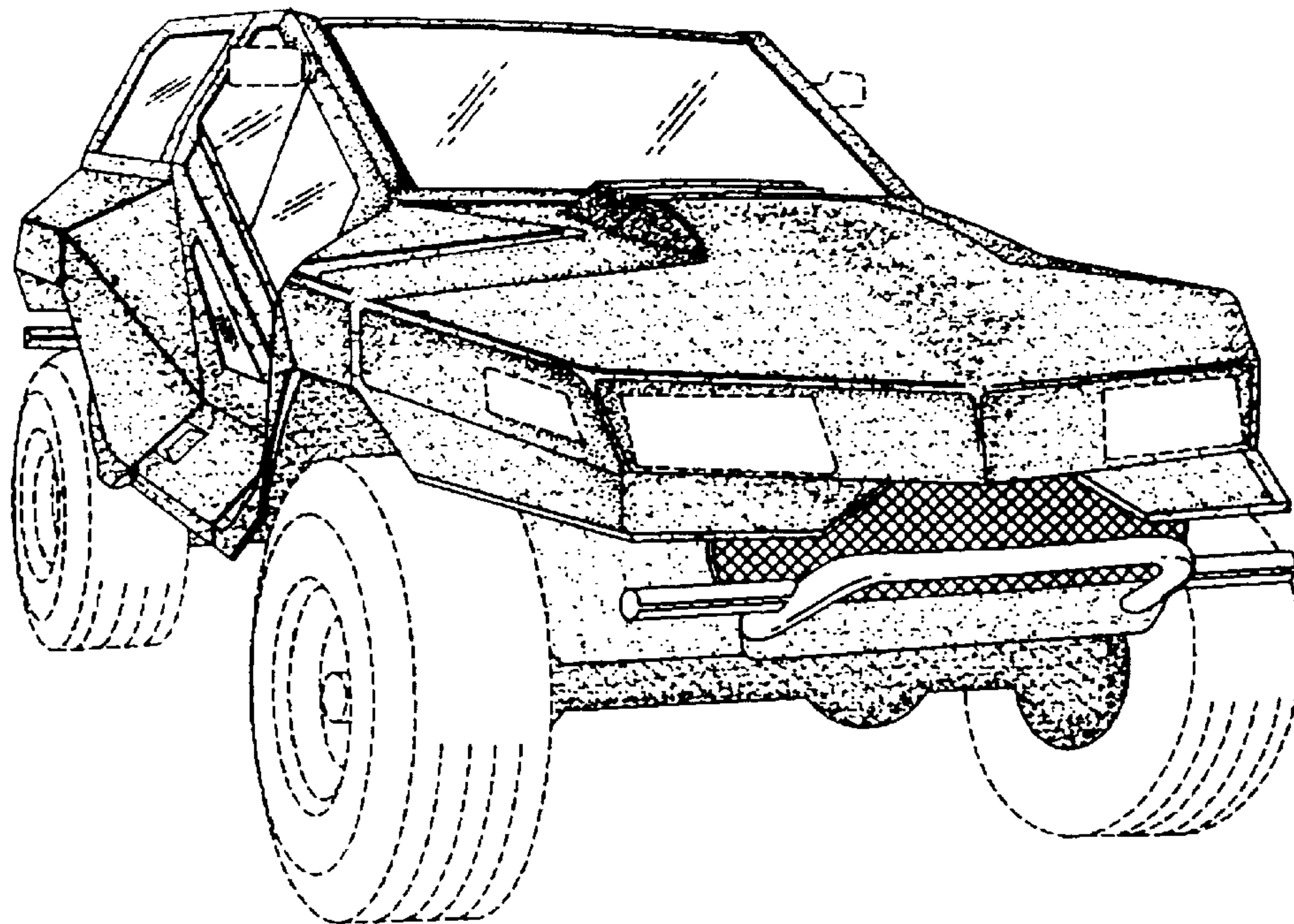
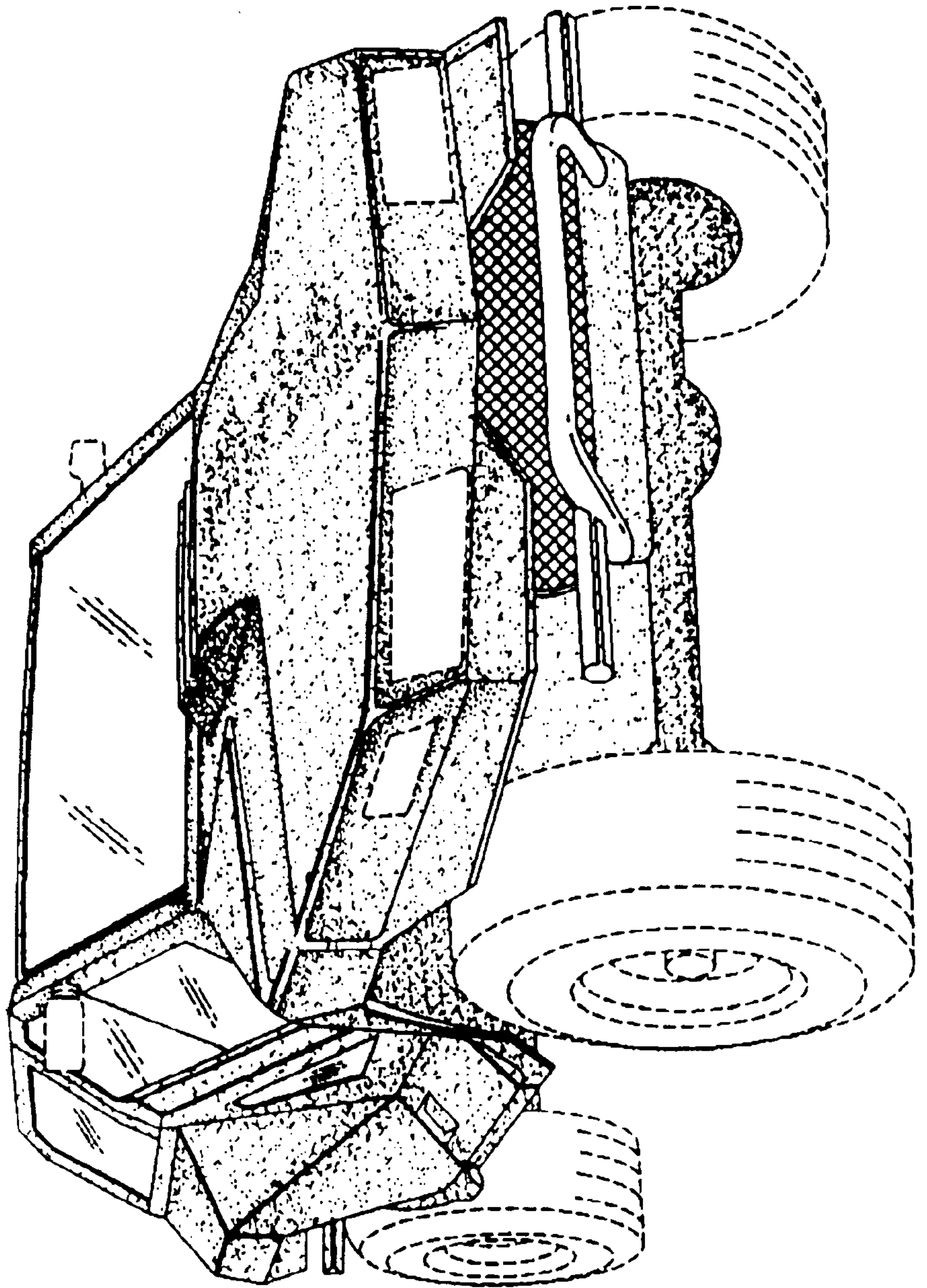

FIG. 1



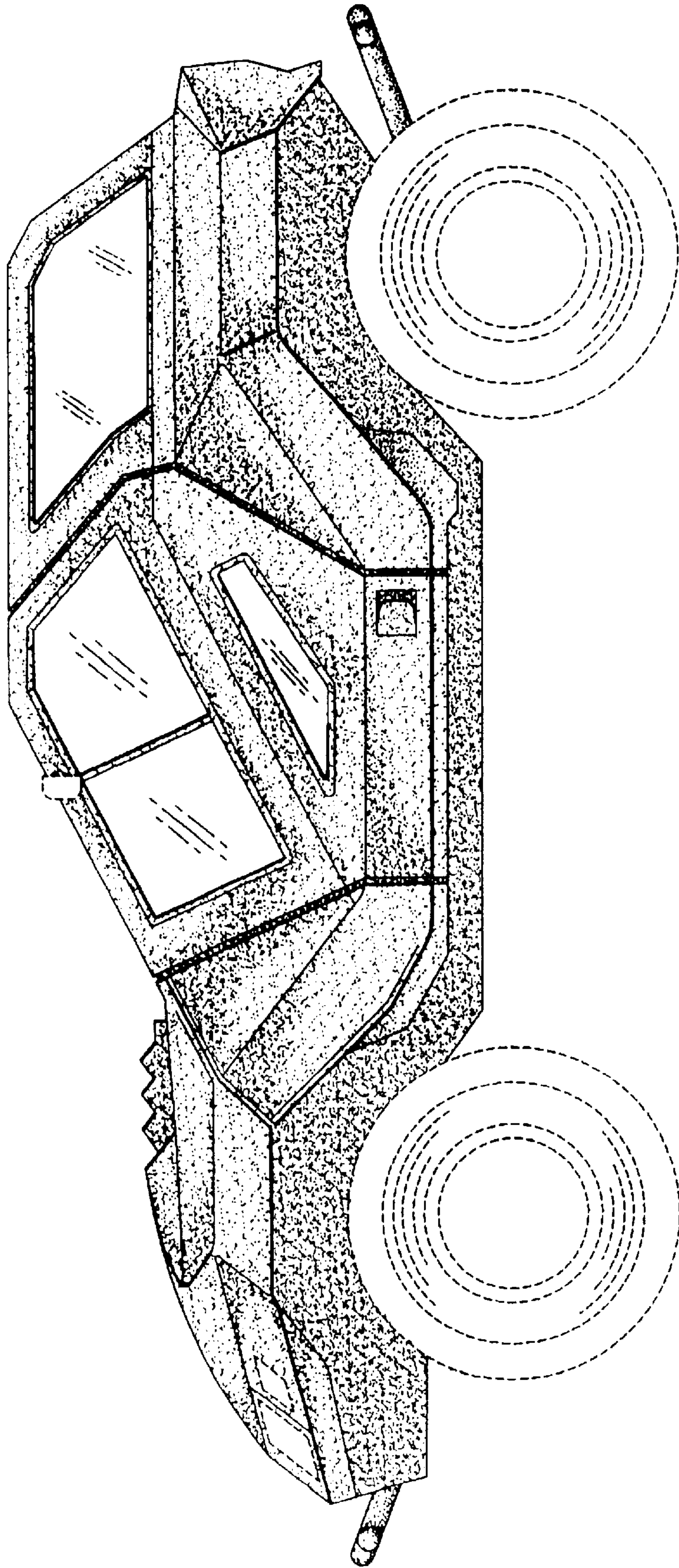

FIG. 2

FIG. 3

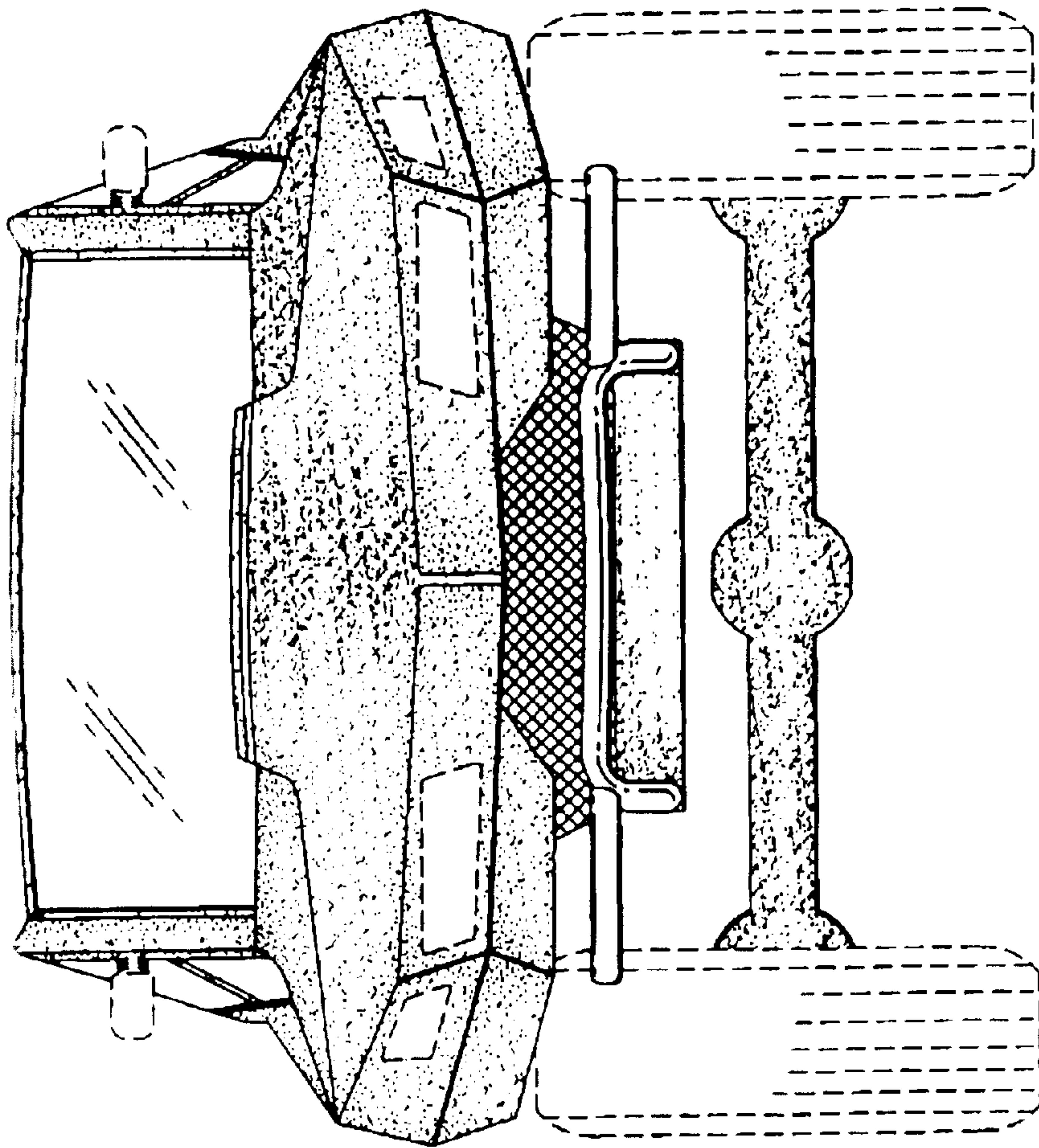

FIG. 4

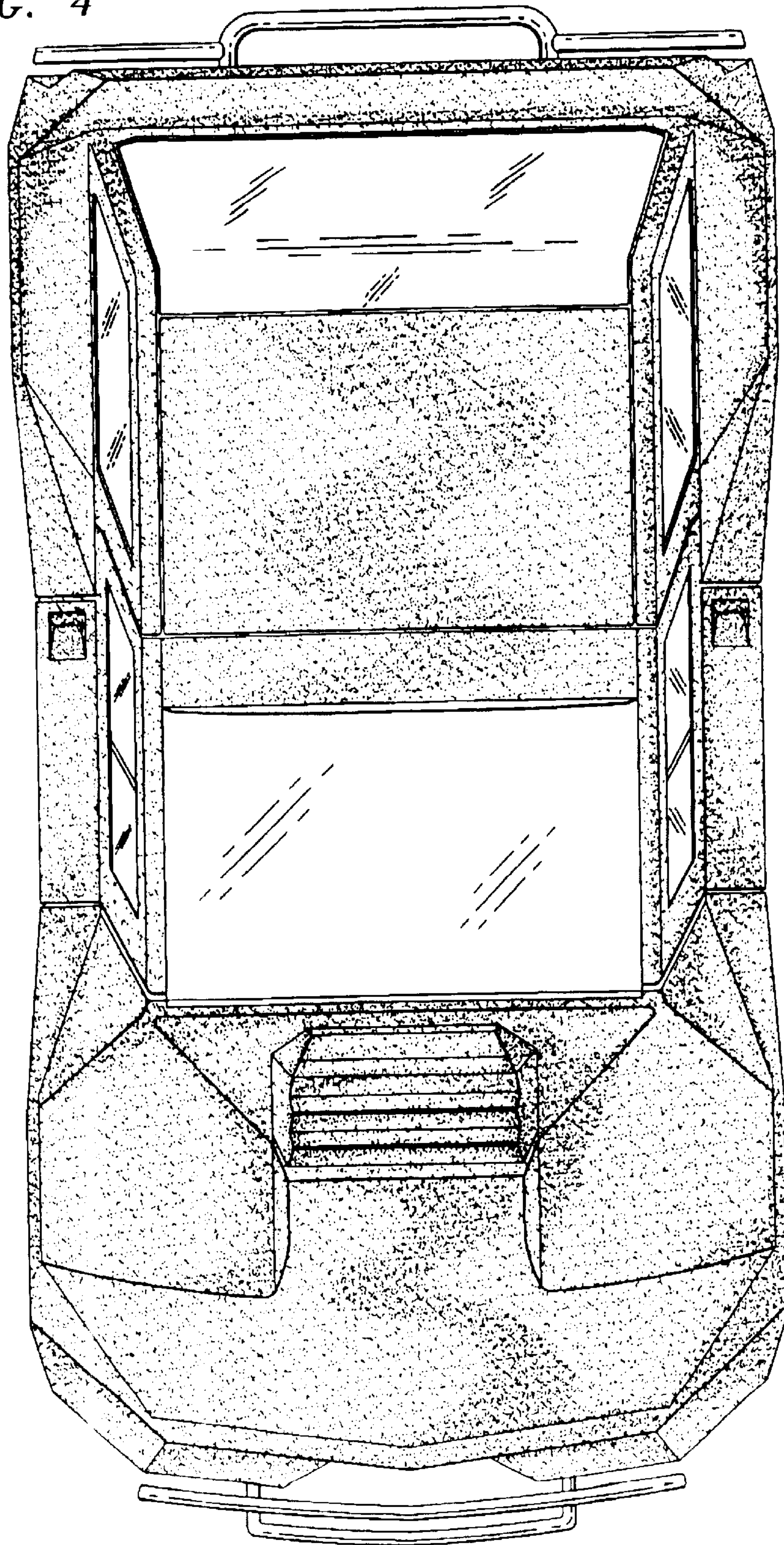

FIG. 5

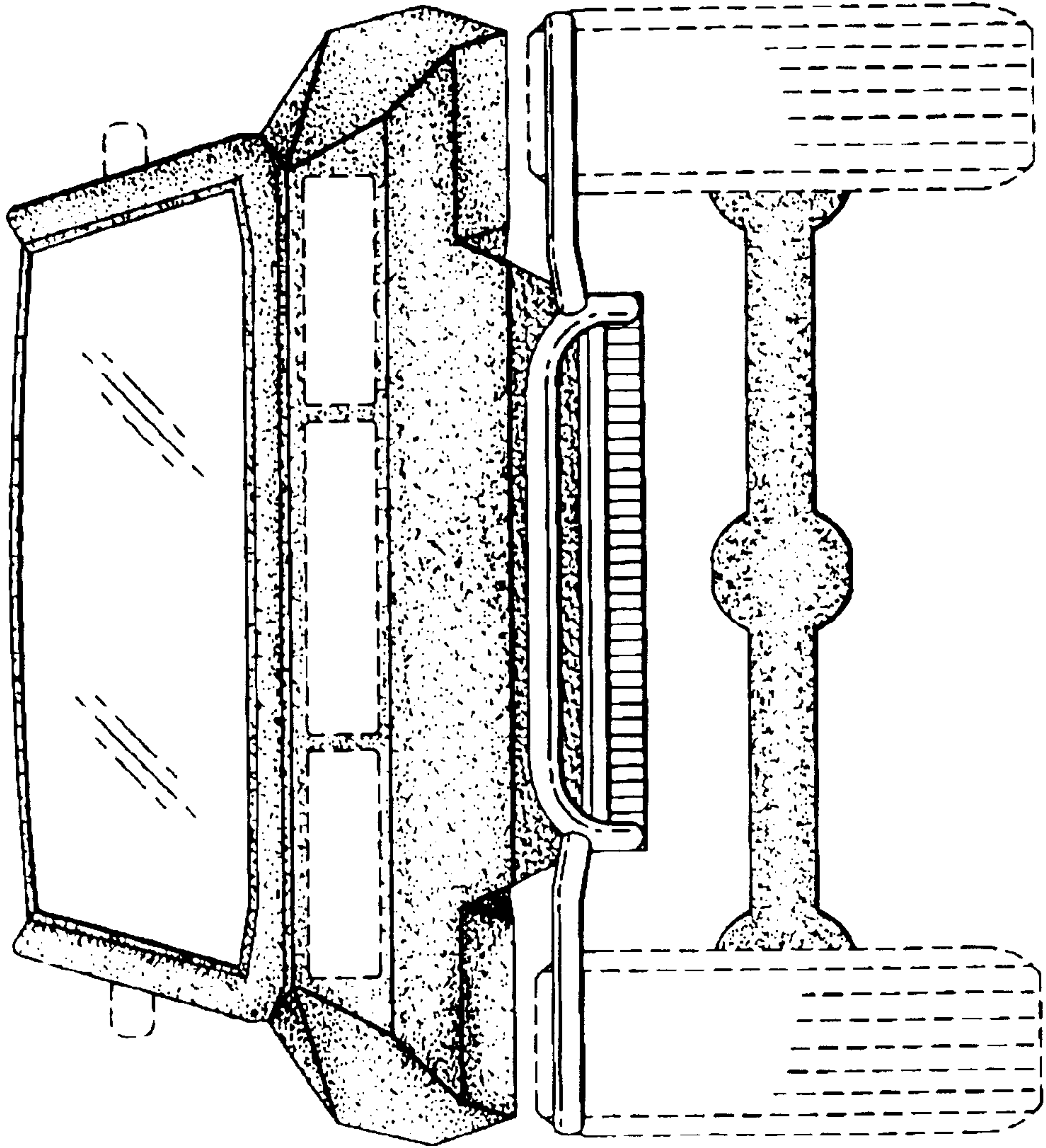

FIG. 6

