



US00D422940S

United States Patent [19]

[11] Patent Number: Des. 422,940

Hanagan et al.

[45] Date of Patent: ** Apr. 18, 2000

[54] VEHICLE

[76] Inventors: **Michael W. Hanagan**, 25980 Paseo Estribo, Monterey, Calif. 93940;
Vincente S. Zavala, 571 Chardonnay Way, Hollister, Calif. 95023

[**] Term: **14 Years**

[21] Appl. No.: **29/096,356**

[22] Filed: **Nov. 11, 1998**

D. 404,688	1/1999	Hanagan et al.	D12/85
3,294,190	12/1966	Suvor et al. .	
3,964,563	6/1976	Allen	180/27
3,983,952	10/1976	McKee	180/65.1
4,216,839	8/1980	Gould et al.	180/65.1
4,313,517	2/1982	Pivar	180/216
4,453,763	6/1984	Richards	296/185
4,573,546	3/1986	Irimajiri et al.	180/89.1
4,671,563	6/1987	Shakespear	196/185
5,305,845	4/1994	Van Dooren	180/65.1
5,343,974	9/1994	Raber	180/216
5,460,234	10/1995	Matsuura et al.	180/65.1

Related U.S. Application Data

[62] Division of application No. 29/078,324, Oct. 21, 1997, Pat. No. Des. 404,688.

[51] LOC (6) Cl. **12-08**

[52] U.S. Cl. **D12/85**

[58] Field of Search D12/85; 296/185; 180/65.1

References Cited

U.S. PATENT DOCUMENTS

D. 242,696	12/1976	Keyes	D12/85
D. 248,461	7/1978	Edmonson	D12/85
D. 260,871	9/1981	Cargile	D12/85
D. 262,871	2/1982	Powers	D12/85
D. 268,402	3/1983	Riley et al.	D12/85
D. 268,920	5/1983	Bragdon	D12/85
D. 273,186	3/1984	Bruning	D12/85
D. 274,995	8/1984	Richards et al.	D12/85
D. 283,113	3/1986	Stollery	D12/85
D. 287,477	12/1986	Takasu	D12/185
D. 320,958	10/1991	Kimura et al.	D12/85
D. 329,211	9/1992	Malewicki	D12/85

FOREIGN PATENT DOCUMENTS

2684606	6/1993	France .
4140508	6/1993	Germany .
5-147562	6/1993	Japan .
5-185940	7/1993	Japan .

Primary Examiner—Melody N. Brown
Attorney, Agent, or Firm—Pepe & Hazard LLP

[57] CLAIM

The ornamental design for a vehicle, as shown and described.

DESCRIPTION

FIG. 1 is a perspective view of a vehicle showing our new design;
FIG. 2 is a top plan view thereof;
FIG. 3 is a front view thereof;
FIG. 4 is a side elevational view thereof;
FIG. 5 is an elevational view of the opposite side thereof; and,
FIG. 6 is a rear elevational view thereof.

1 Claim, 6 Drawing Sheets

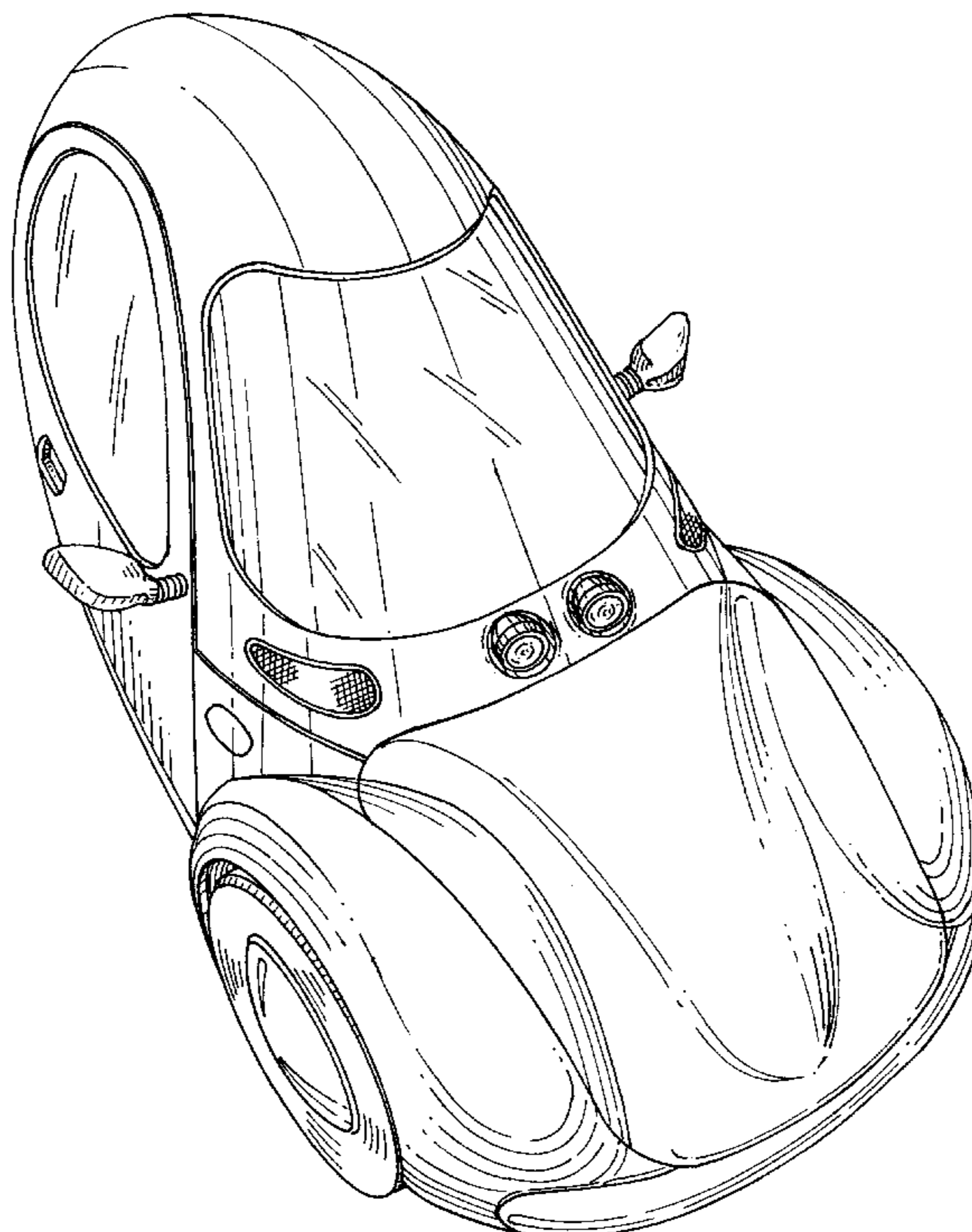

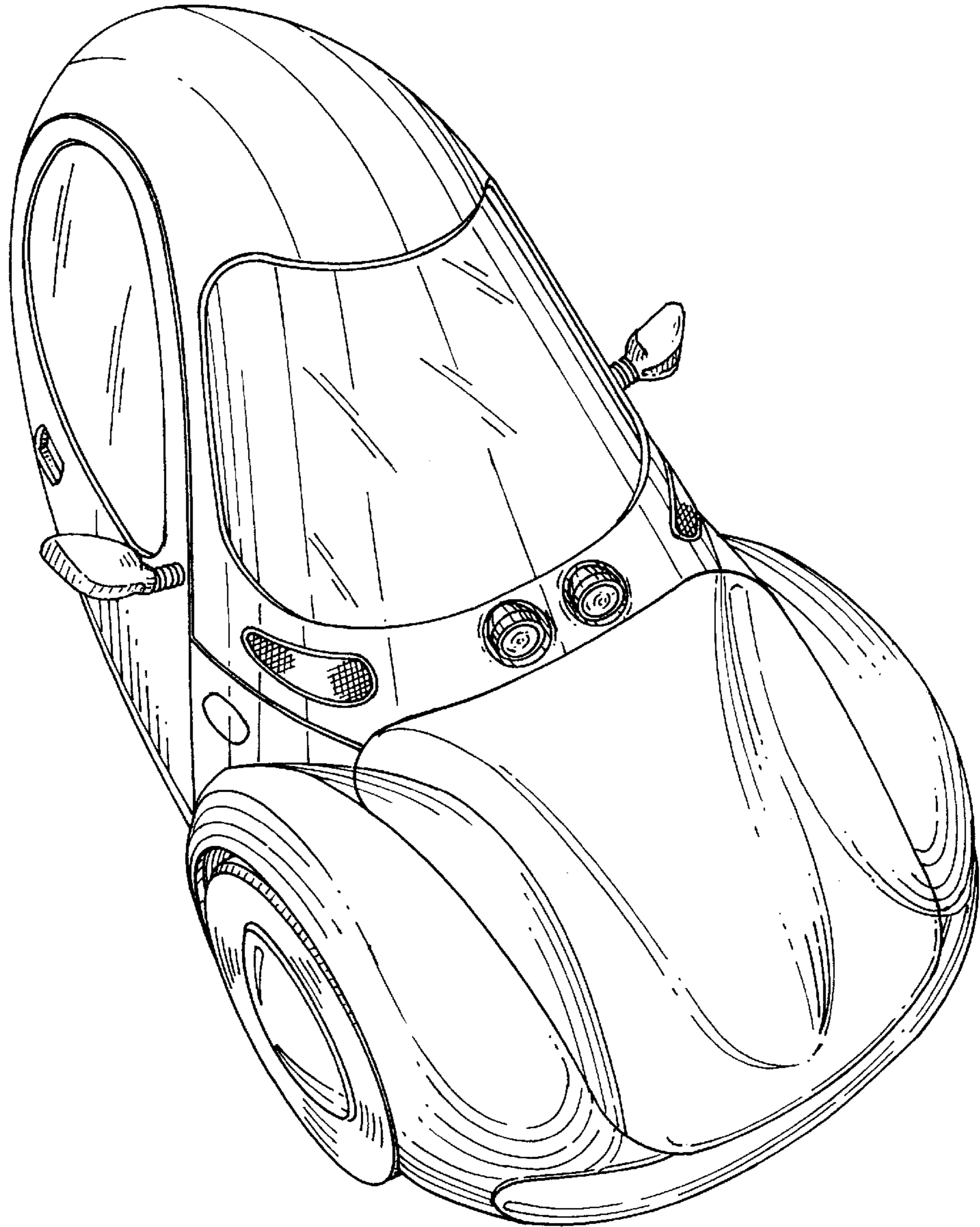

FIG. 1

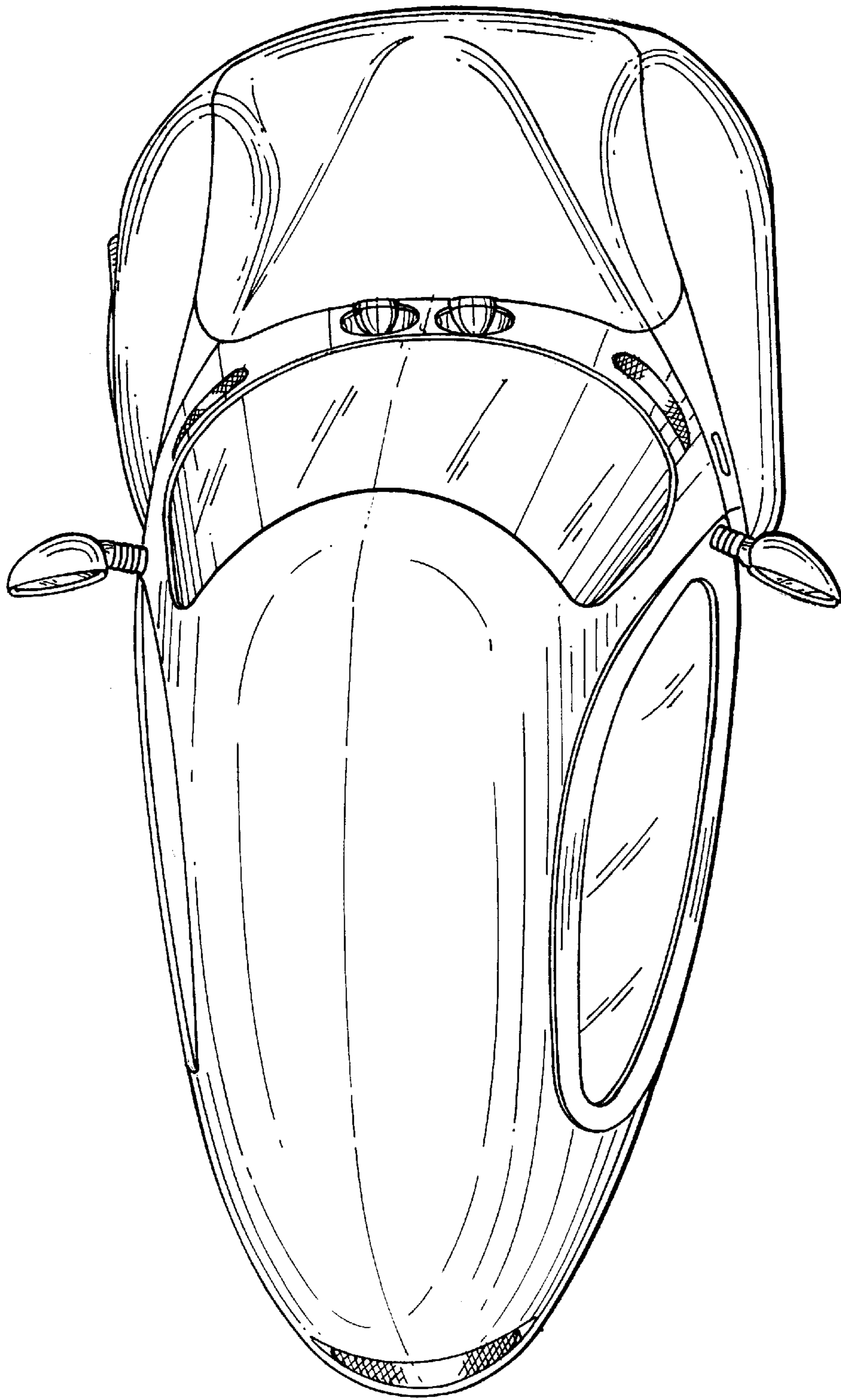

FIG. 2

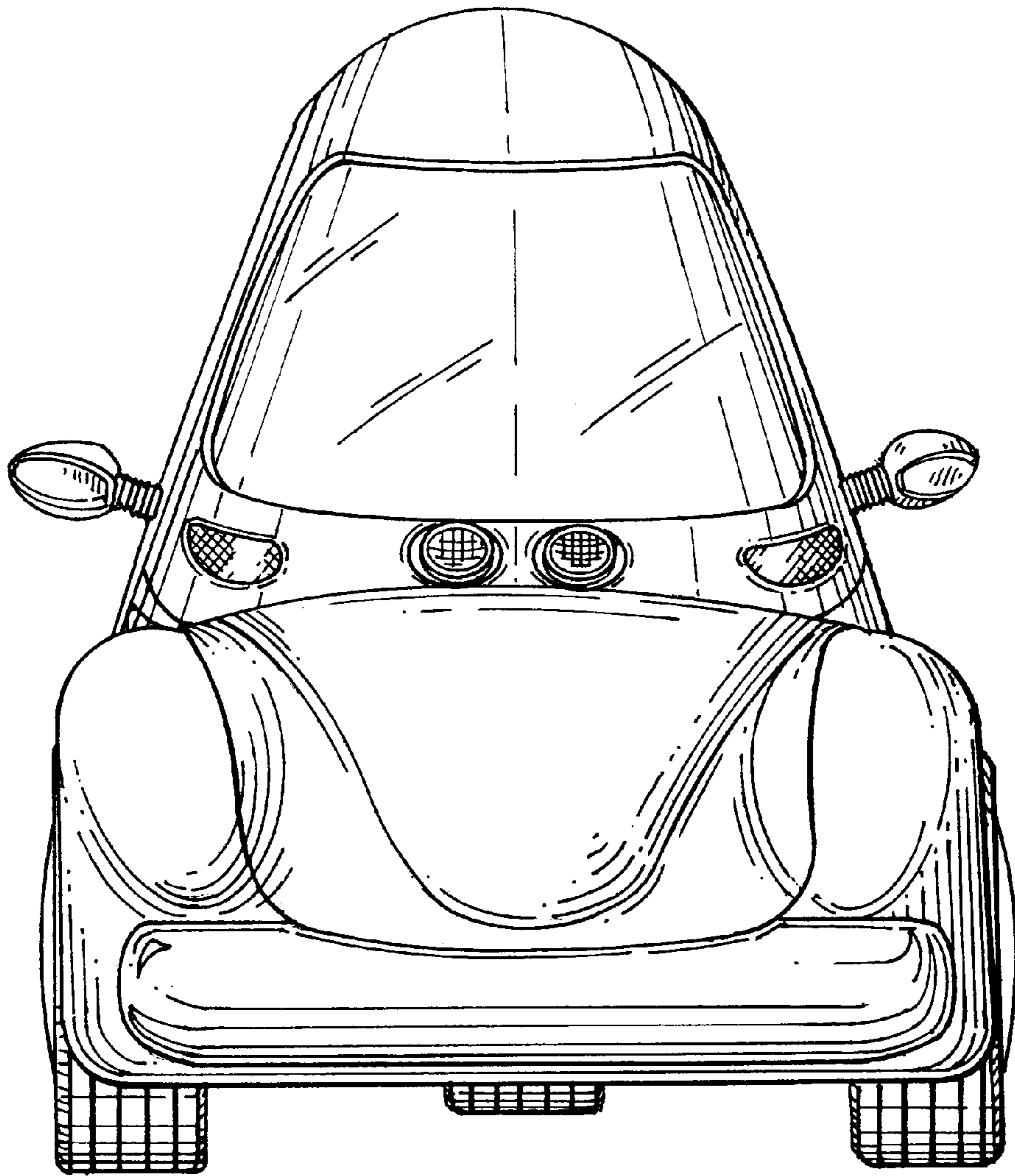

FIG. 3

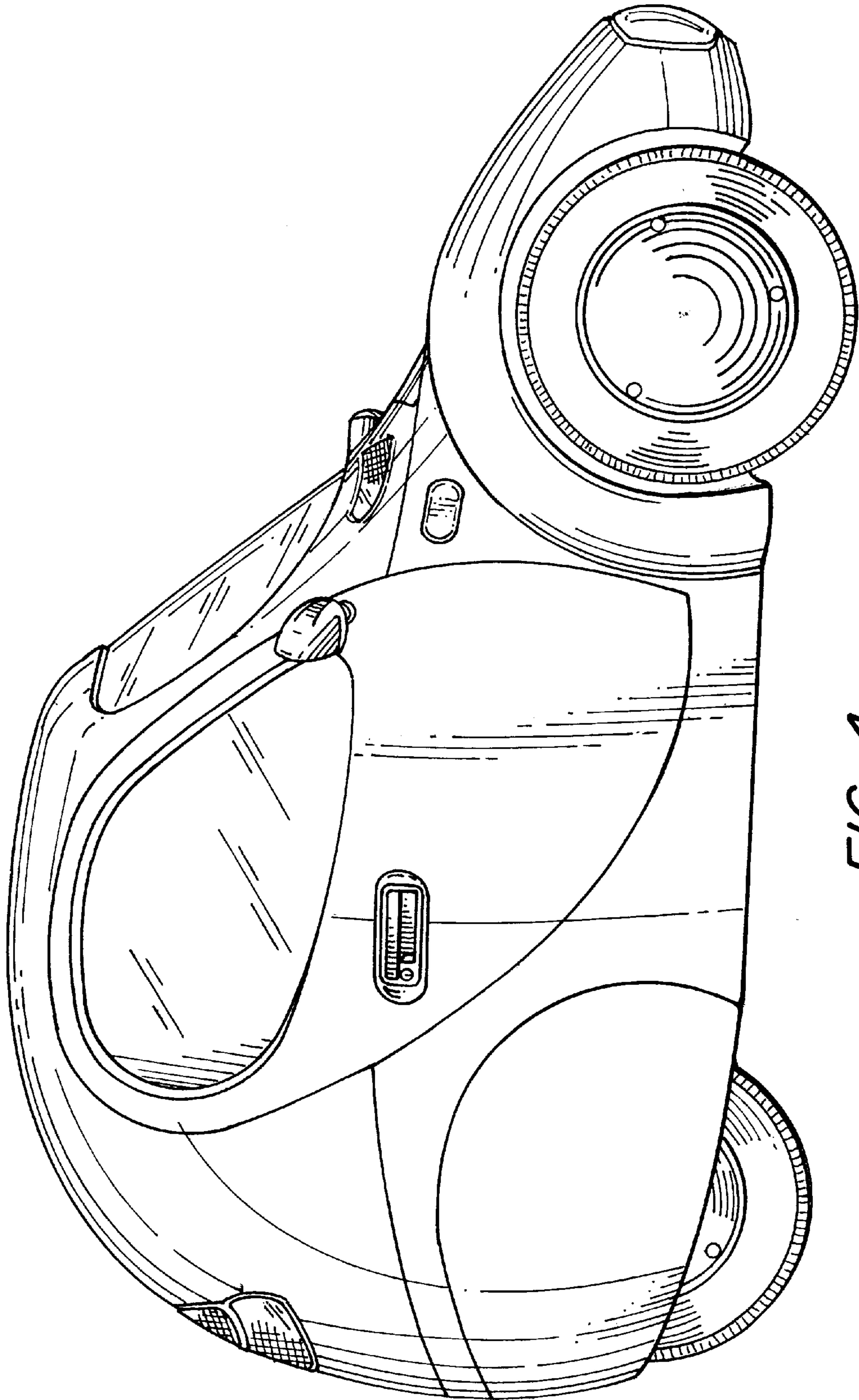

FIG. 4

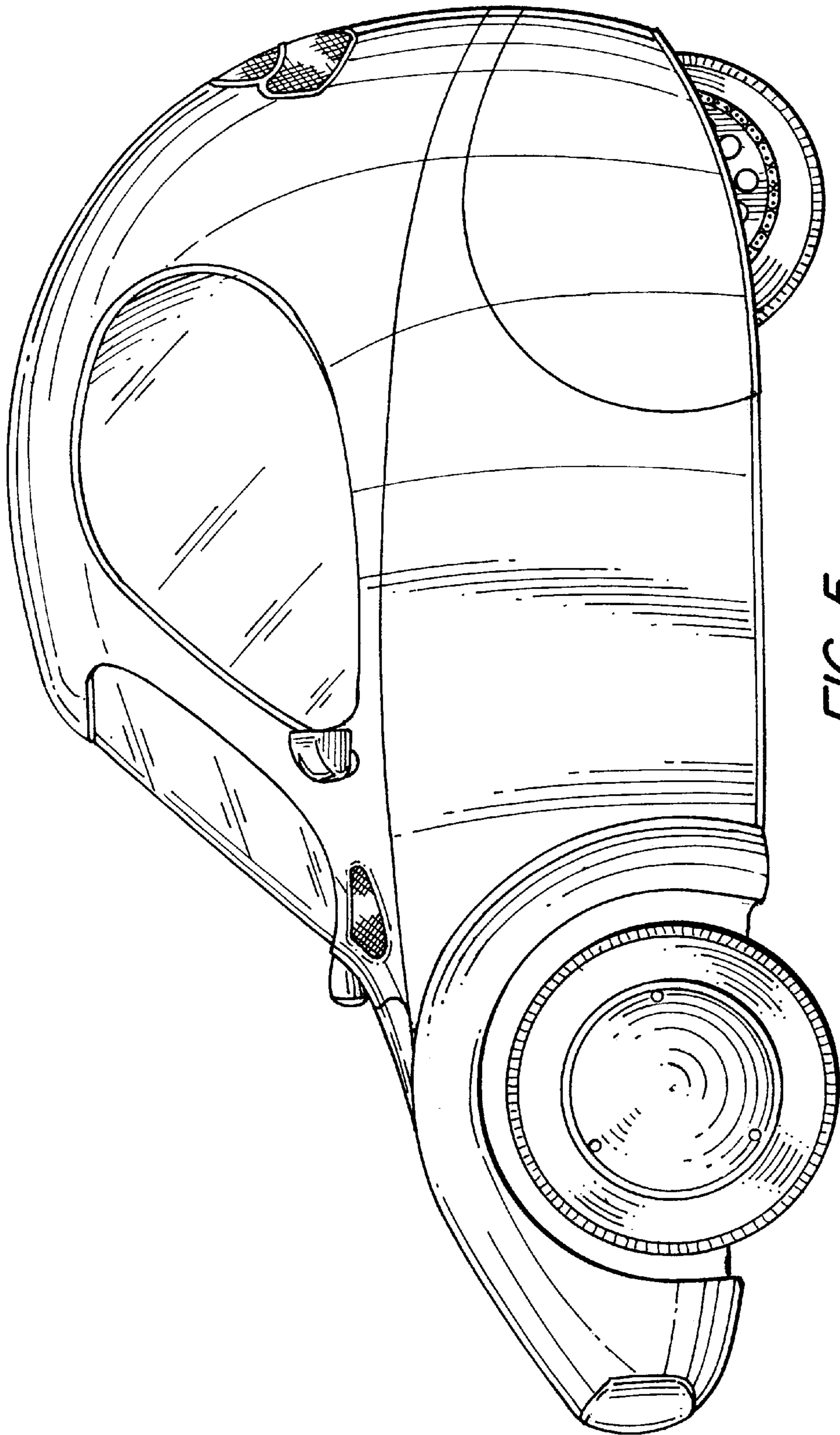

FIG. 5

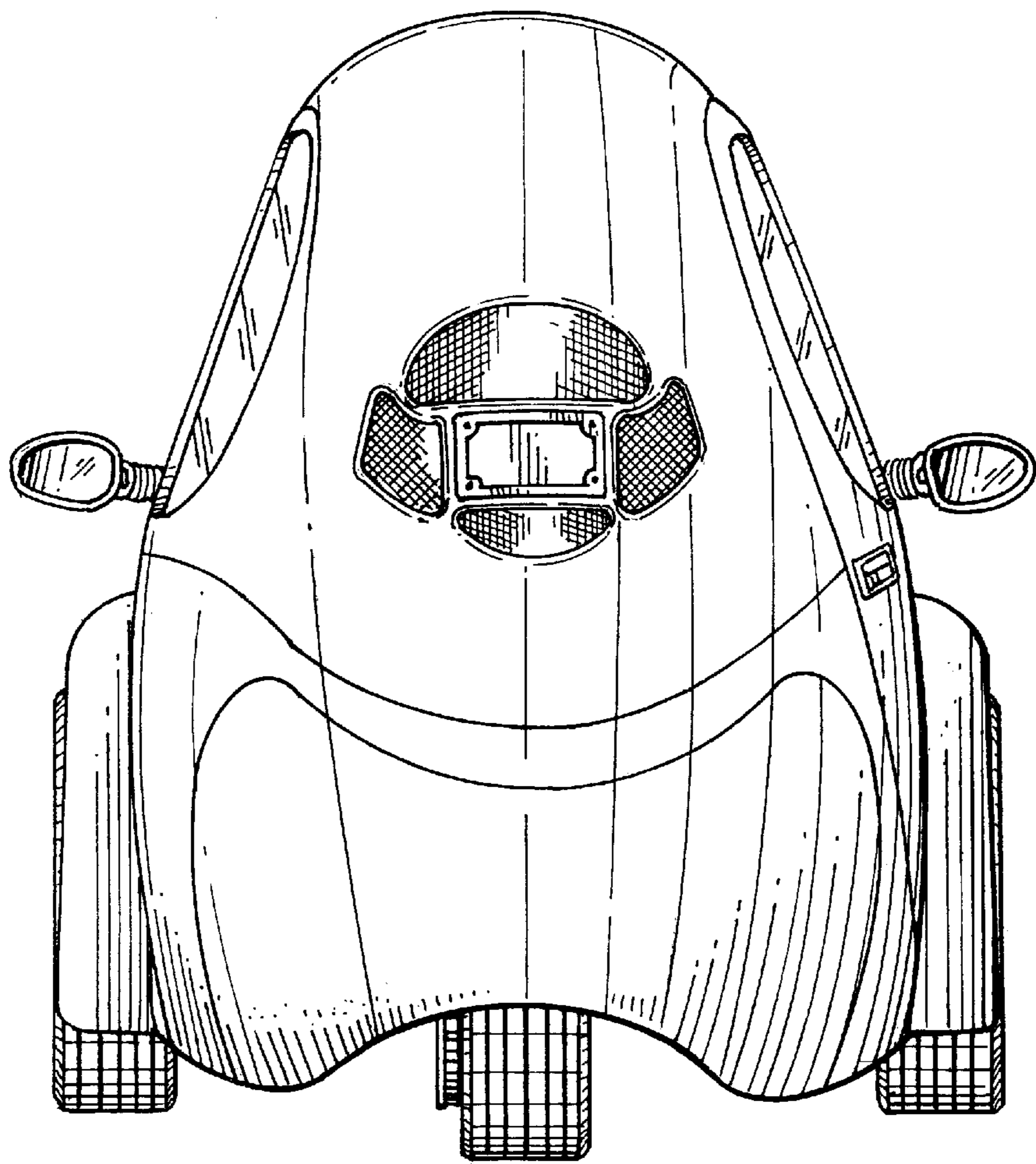

FIG. 6