



US00D422749S

# United States Patent [19]

**Binstock et al.**

[11] **Patent Number: Des. 422,749**

[45] **Date of Patent: \*\* \*Apr. 11, 2000**

[54] **DETERGENT TABLET**

[75] Inventors: **Gary Benjamin Binstock**, Basking Ridge, N.J.; **Bruce Cummings**, New York, N.Y.; **Divaker Kenkare**, Califon, N.J.; **Kevin Mark Kinscherf**, Freehold, N.J.; **Steve Mark Phillips**, Highland Park, N.J.

[73] Assignee: **Colgate-Palmolive Company**, New York, N.Y.

[\*] Notice: This patent is subject to a terminal disclaimer.

[\*\*] Term: **14 Years**

[21] Appl. No.: **29/085,319**

[22] Filed: **Mar. 20, 1998**

[51] **LOC (6) Cl. .... 28-03**

[52] **U.S. Cl. .... D28/8.1**

[58] **Field of Search .... D28/8.1, 8.2; D23/207, D23/208; D24/100-104; 510/137-149, 440, 446-449, 224, 225; 424/457-474**

### [56] **References Cited**

#### U.S. PATENT DOCUMENTS

D. 217,889	6/1970	Koenigsberg	.....	D28/8.1
237,861	2/1881	Hare	.....	248/690
D. 269,721	7/1983	Tovey	.....	D28/8.1 X
D. 283,931	5/1986	Baum	.....	D24/101
D. 285,490	9/1986	Tovey	.....	D28/801 X
D. 286,086	10/1986	Tovey	.....	D24/101
D. 298,062	10/1988	Bussell	.....	D28/8.1
D. 301,762	6/1989	Oshlack	.....	D24/103
D. 376,643	12/1996	Hatton et al.	.....	D24/101
D. 403,396	12/1998	Lundbom et al.	.....	D24/101
790,319	5/1905	Samuel	.....	510/440
1,981,249	11/1934	Rosenblatt	.....	510/142
2,271,959	2/1942	Swanson	.....	510/449
3,557,003	1/1971	Morris et al.	.....	510/298
4,253,842	3/1981	Erlich	.....	510/277
4,460,490	7/1984	Barford et al.	.....	510/192
4,578,207	3/1986	Holdt et al.	.....	510/192

4,946,685	8/1990	Edgren et al.	.....	424/473 X
5,084,277	1/1992	Greco et al.	.....	424/464 X
5,262,132	11/1993	Bricker et al.	.....	422/263

#### FOREIGN PATENT DOCUMENTS

292291 6/1928 United Kingdom .

#### OTHER PUBLICATIONS

Australian Trade Mark No. 36,569, registered Jul. 17, 1923. Drug Standards Sep./Oct. 1959, p. 126: tablet and capsule shapes in rows A and B.

Blair Co. Cat No. 766 of 1969, p. 24: soaps indicated by arrows.

Physician's Desk Reference 49 Edition 1995; 1) p. 305: Demadex™ 100 mg tablet on right 2) p. 330: Flagyl® 500 mg tablet 3) p. 331: Ralefen® 750 mg tablet 4) p. 334: Motrin® 600 & 800 mg tablets.

*Primary Examiner*—Ted Shooman

*Assistant Examiner*—C Tuttle

*Attorney, Agent, or Firm*—Michael McGreal

#### [57] **CLAIM**

The ornamental design for a detergent tablet, shown and described.

#### DESCRIPTION

FIG. 1 is a perspective view of the detergent tablet of our design;

FIG. 2 is a front and rear elevation view thereof;

FIG. 3 is a left and right side elevation view thereof;

FIG. 4 is a top and bottom plan view thereof;

FIG. 5 is a perspective view of a second embodiment of the detergent tablet of our design;

FIG. 6 is a front and rear elevation view thereof;

FIG. 7 is a left and right side elevation view thereof;

FIG. 8 is a top and bottom plan view thereof;

FIG. 9 is a perspective view of a third embodiment of the detergent tablet of our design;

FIG. 10 is a front and rear elevation view thereof;

FIG. 11 is a left and right side elevation view thereof; and,

FIG. 12 is a top and bottom plan view thereof.

**1 Claim, 1 Drawing Sheet**

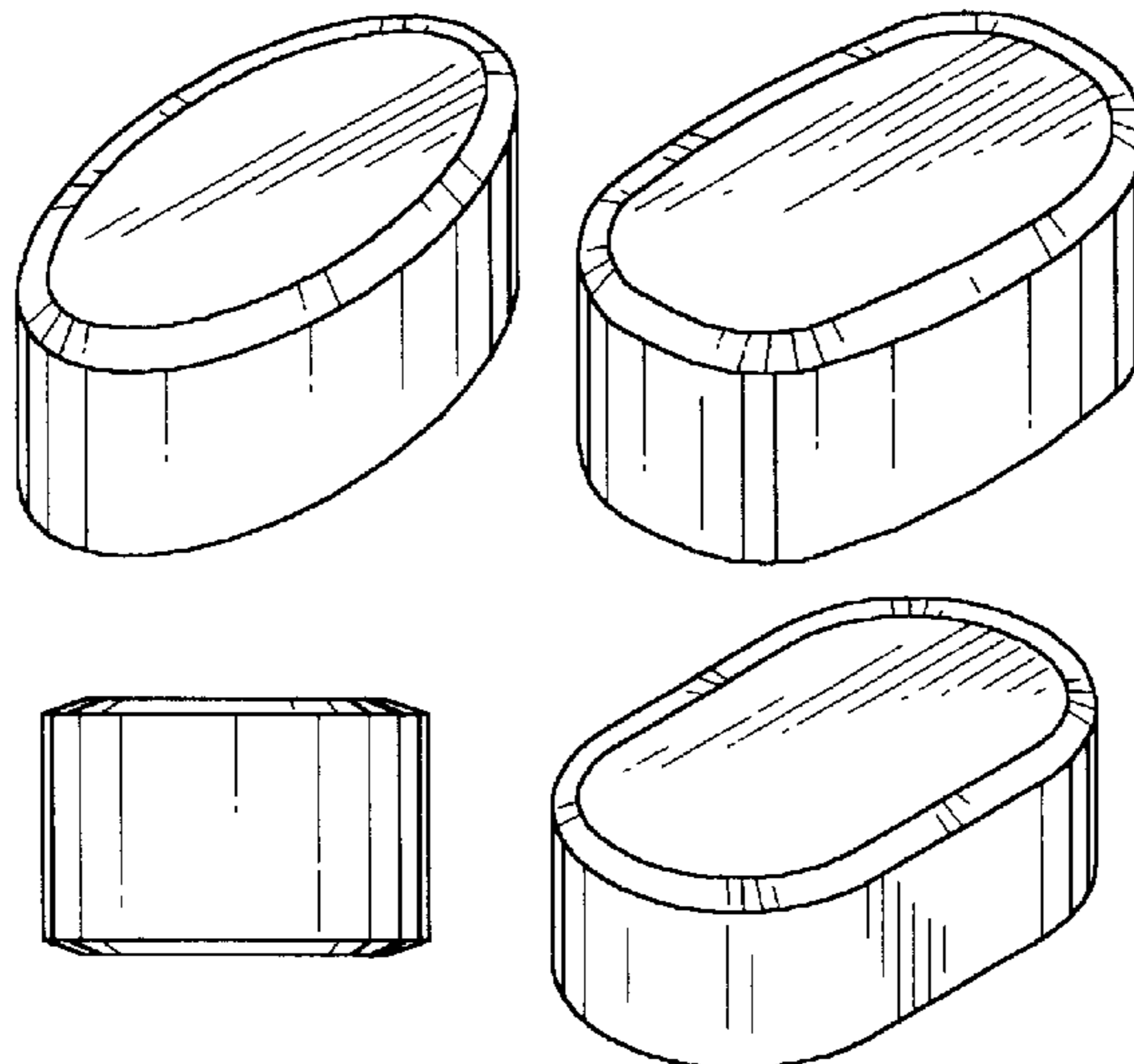

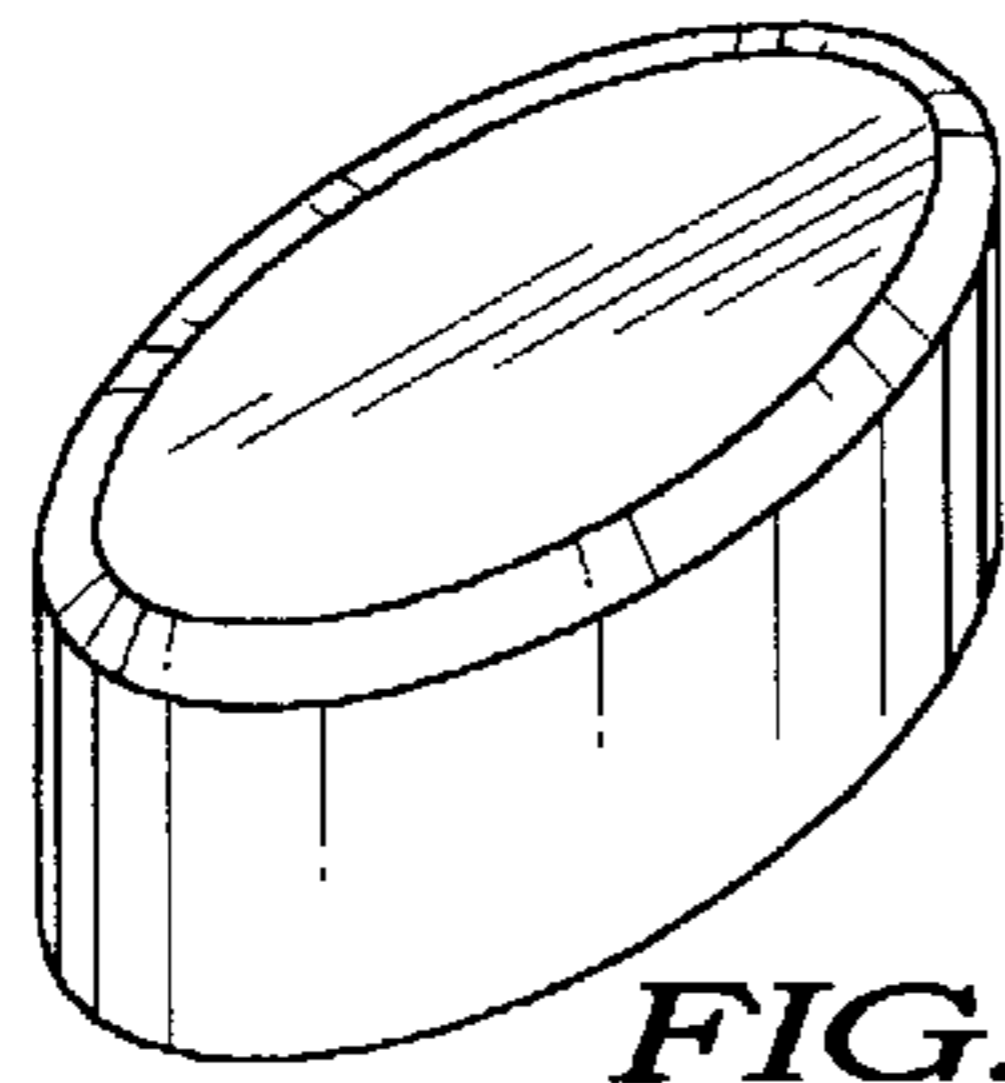

FIG. 1

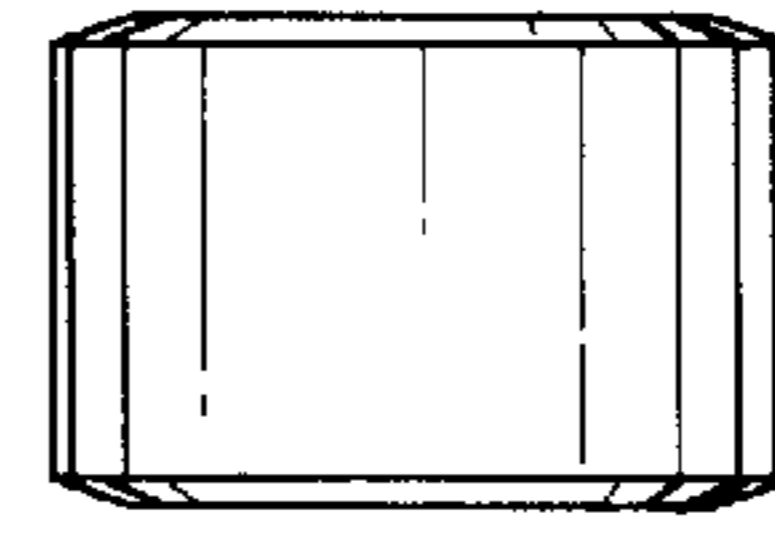

FIG. 3

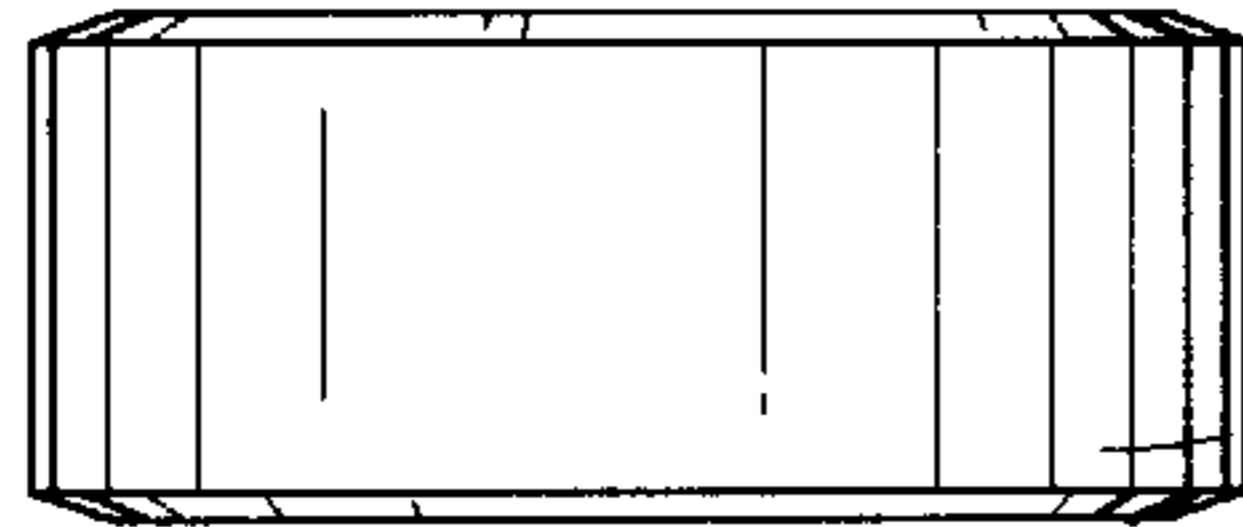

FIG. 2

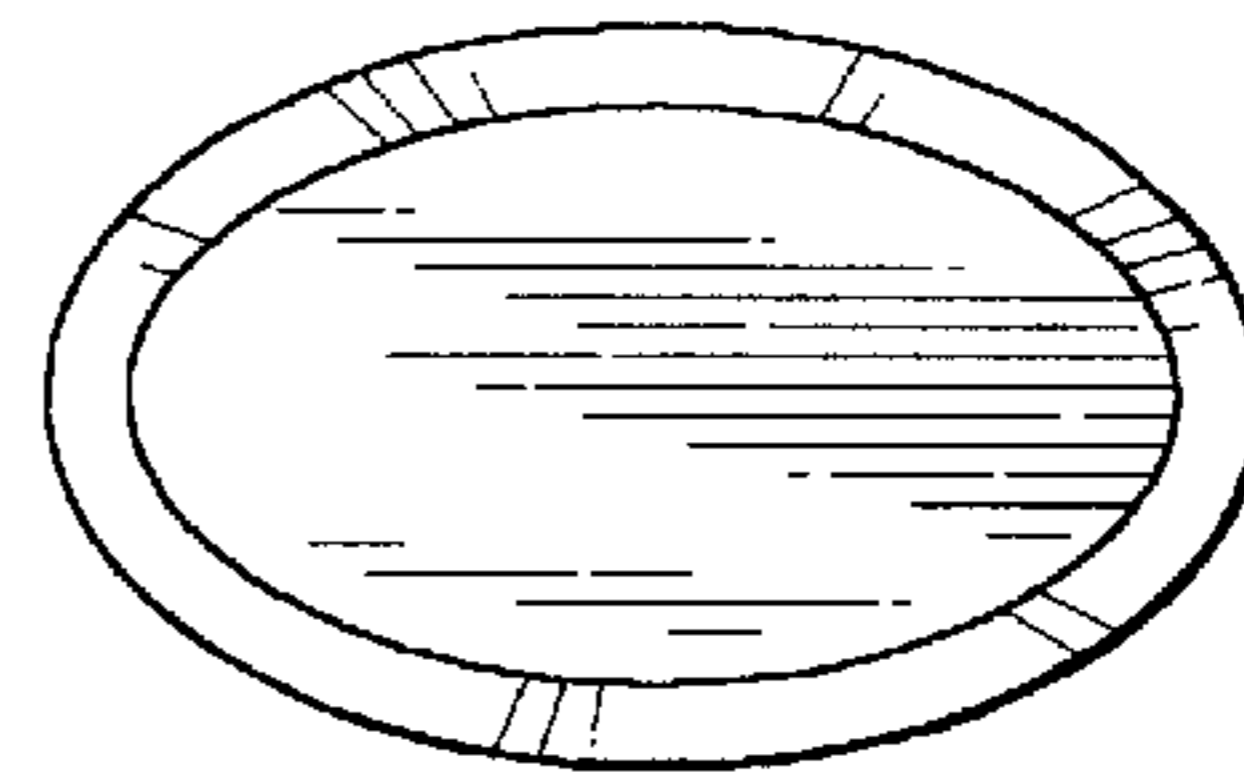

FIG. 4

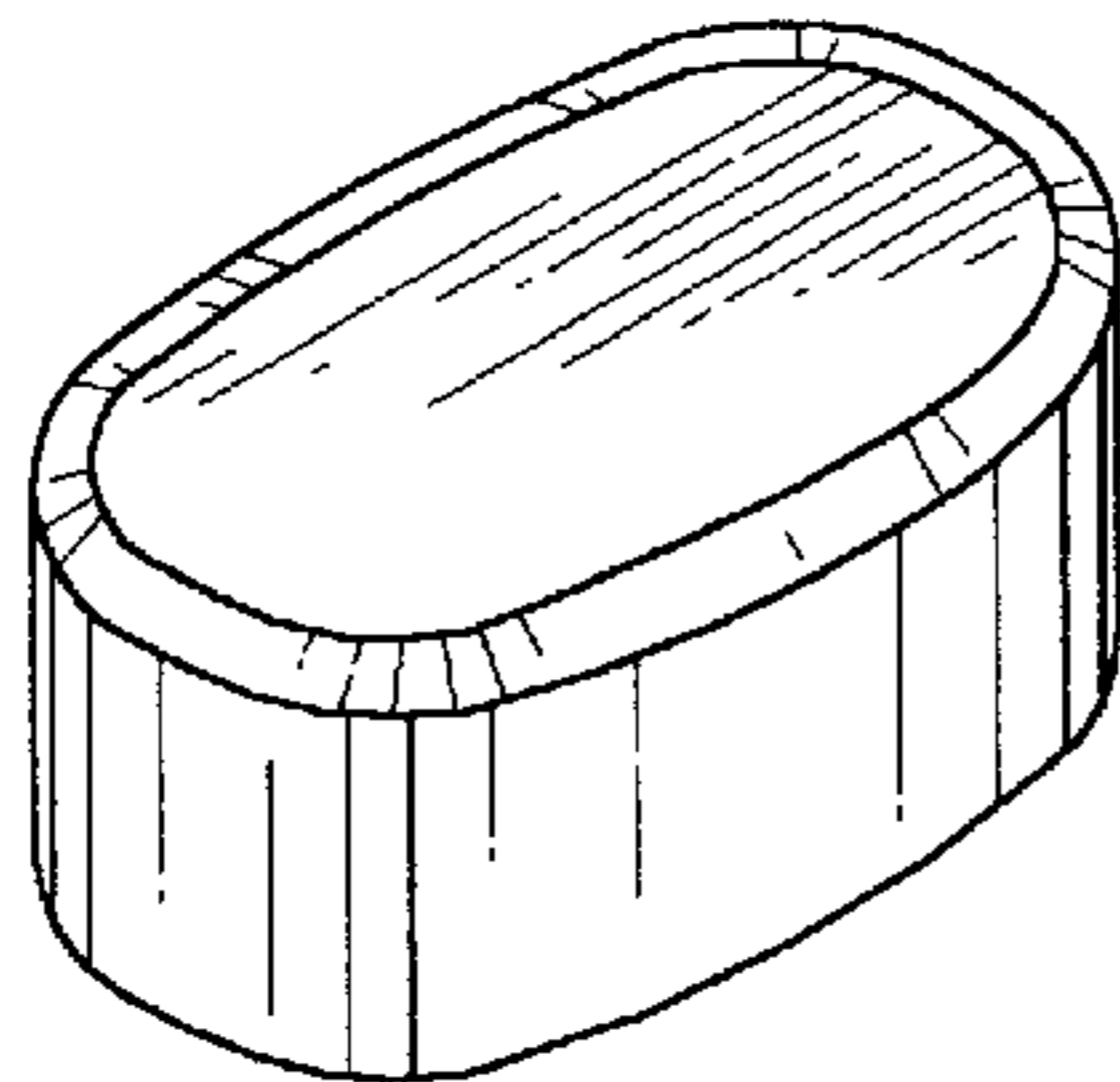

FIG. 5

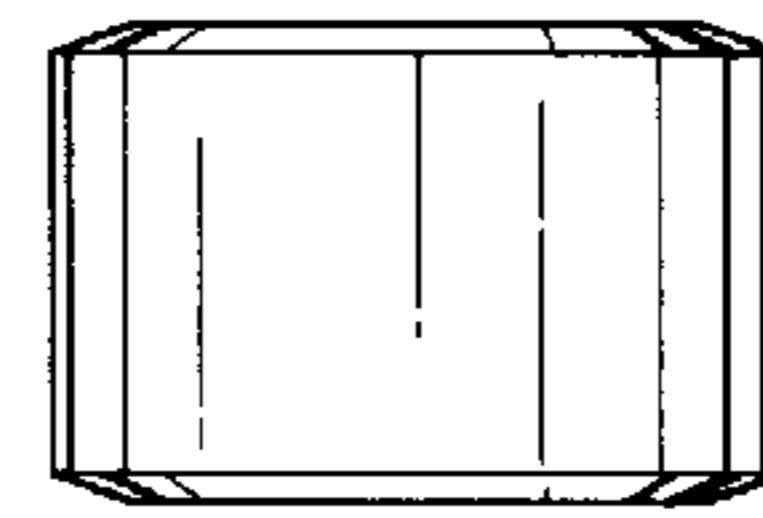

FIG. 7

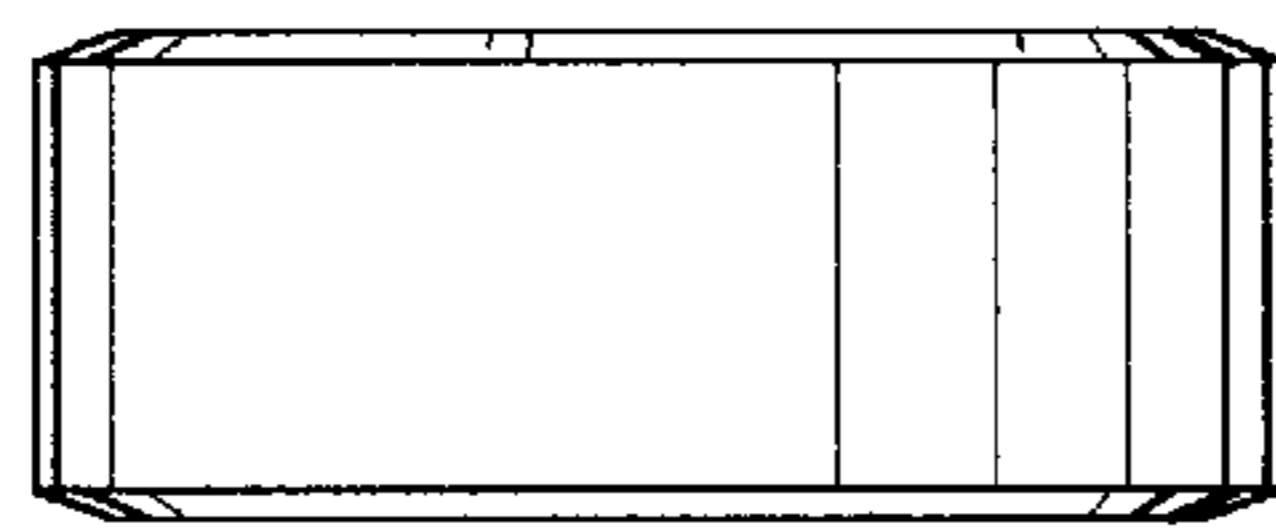

FIG. 6

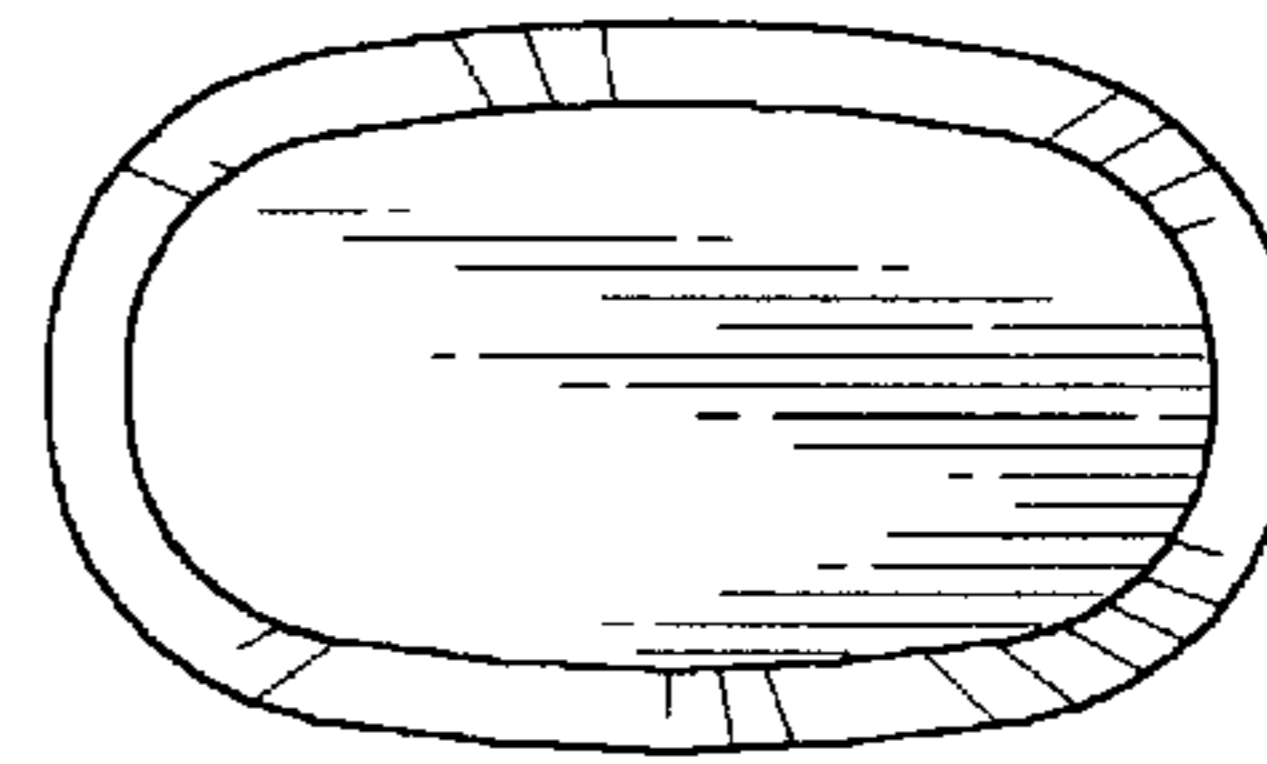

FIG. 8

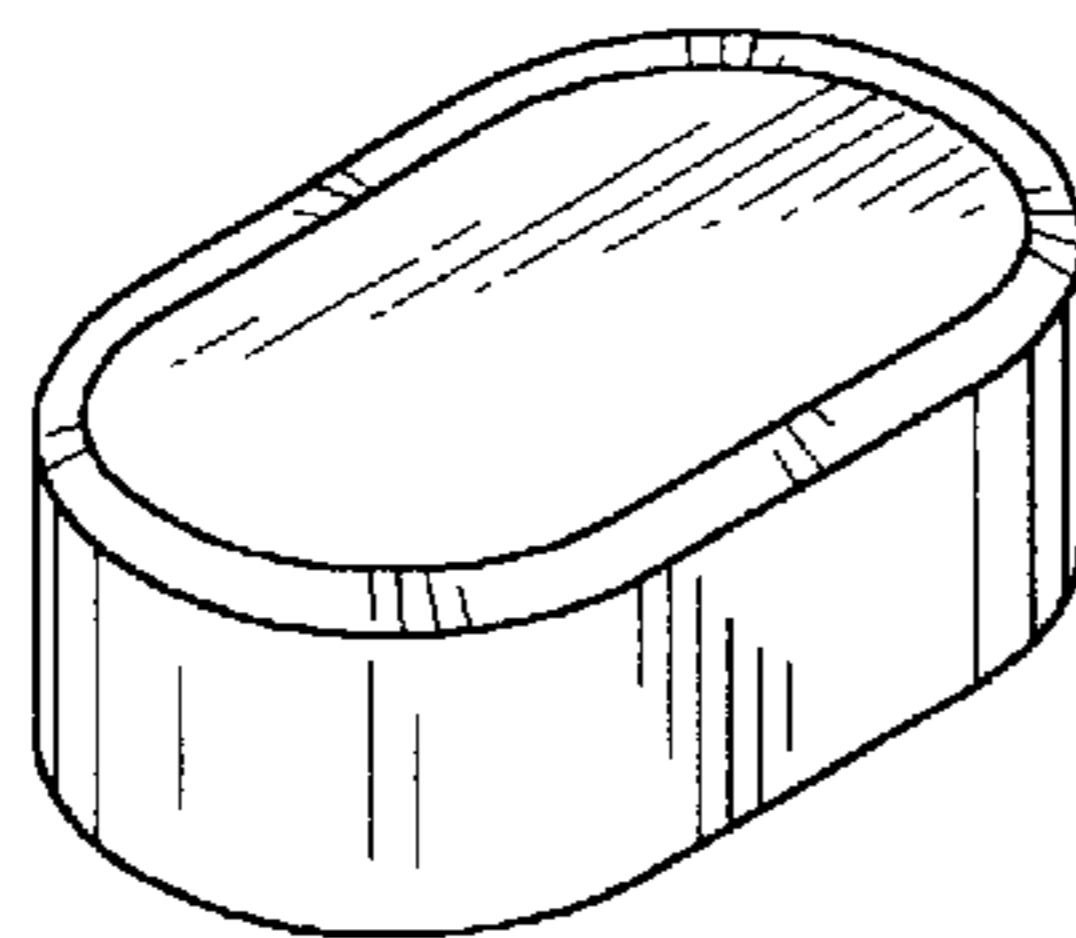

FIG. 9

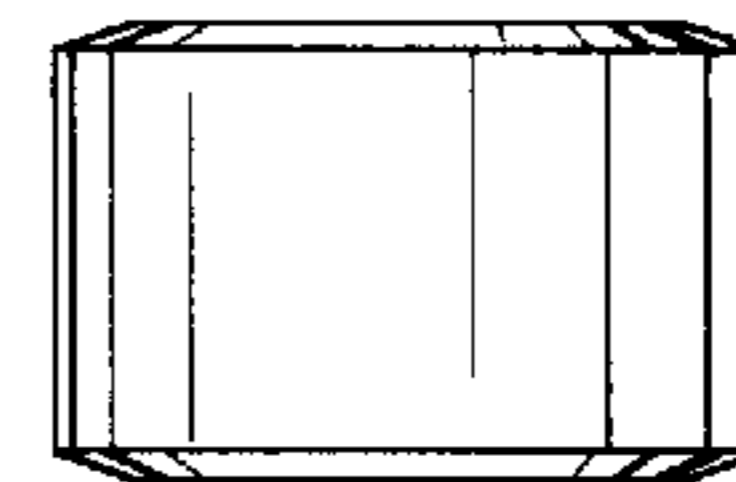

FIG. 11

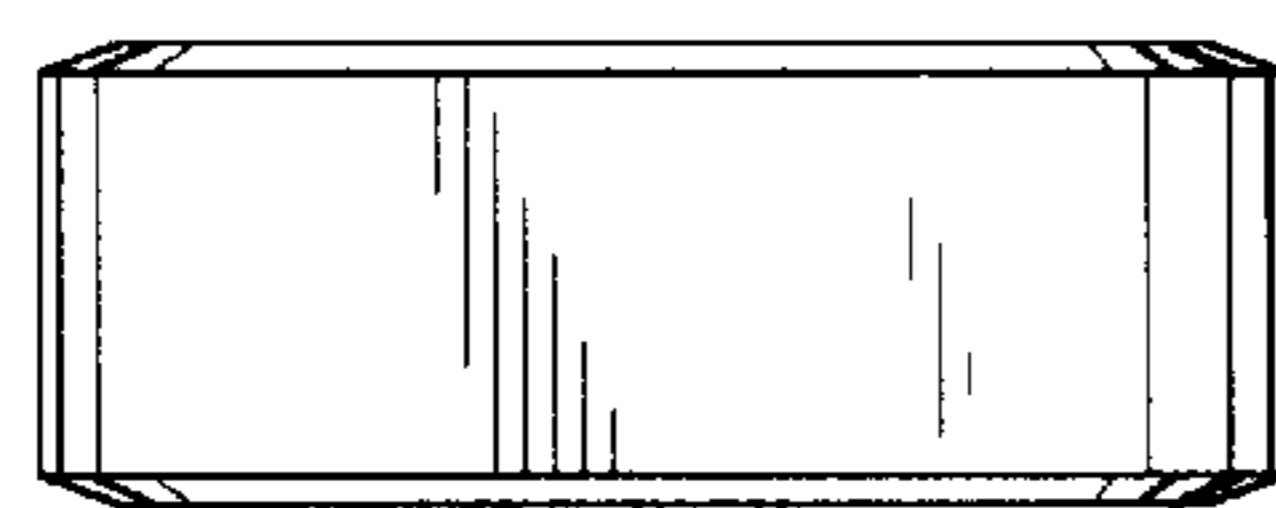

FIG. 10

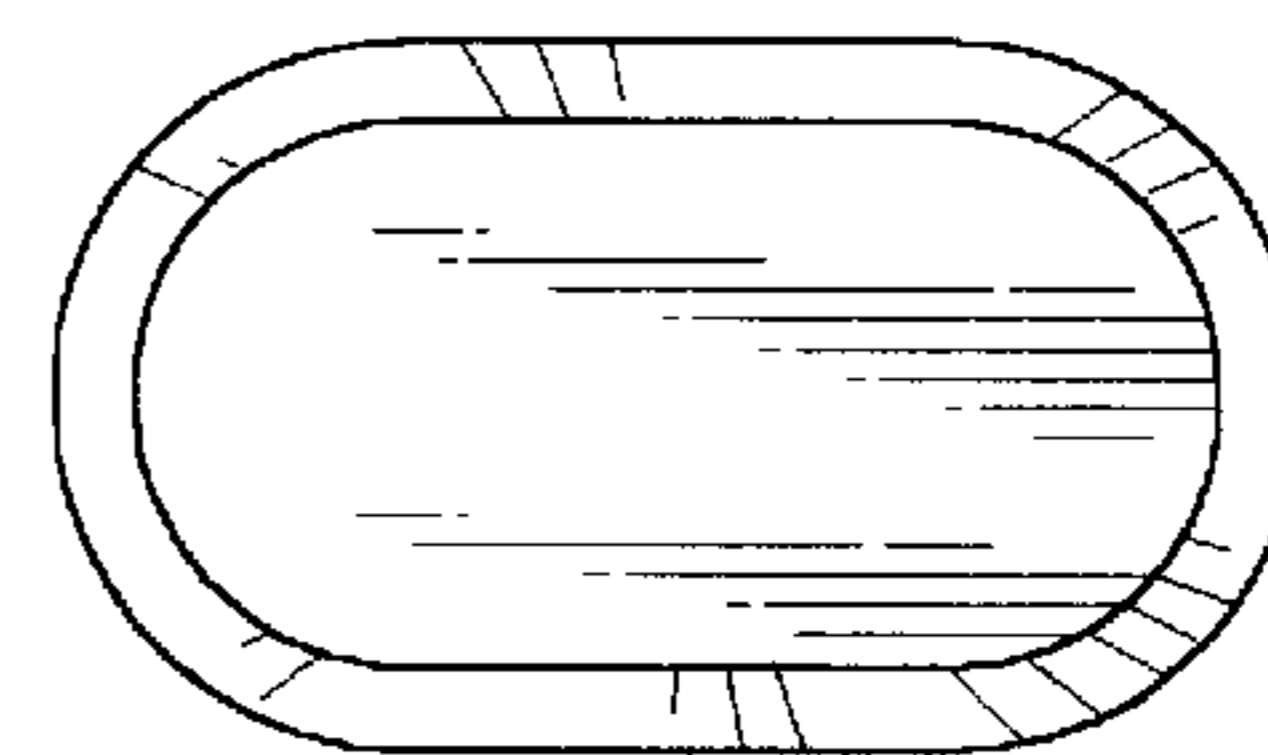

FIG. 12