



US00D422254S

United States Patent [19]

[11] **Patent Number: Des. 422,254**

Toyoda

[45] **Date of Patent: ** Apr. 4, 2000**

[54] **REAR PORTION OF A MOTOR VEHICLE**

*Attorney, Agent, or Firm—*Sidley & Austin; Hugh A. Abrams

[75] Inventor: **Tsuyoshi Toyoda**, Aki-gun, Japan

[57] **CLAIM**

[73] Assignee: **Mazda Motor Corporation**, Hiroshima-Ken, Japan

The ornamental design for a rear portion of a motor vehicle, as shown and described.

[**] Term: **14 Years**

DESCRIPTION

[21] Appl. No.: **29/094,306**

FIG. 1 is a perspective view of a first rear portion of a motor vehicle;

[22] Filed: **Sep. 30, 1998**

FIG. 2 is a front view of the first rear portion;

[30] **Foreign Application Priority Data**

FIG. 3 is a left side view of the first rear portion, the opposite side being a mirror image of the side shown herein;

Mar. 31, 1998 [JP] Japan 10-9224

FIG. 4 is a top view of the first rear portion;

[51] **LOC (6) Cl.** **12-16**

FIG. 5 is a perspective view of a second rear portion of a motor vehicle;

[52] **U.S. Cl.** **D12/196**

FIG. 6 is a front view of the second rear portion;

[58] **Field of Search** D12/196, 90-92;

FIG. 7 is a left side view of the second rear portion, the opposite side being a mirror image of the side shown herein;

296/185

and,

[56] **References Cited**

FIG. 8 is a top view of the second rear portion.

U.S. PATENT DOCUMENTS

The portion of the motor vehicle shown in broken lines is for illustrative purpose only and forms no part of the claimed design.

D. 373,342 9/1996 Moore D12/196

D. 395,259 6/1998 Ohsawa et al. D12/91

D. 395,619 6/1998 Cho D12/91

*Primary Examiner—*Melody N. Brown

1 Claim, 8 Drawing Sheets

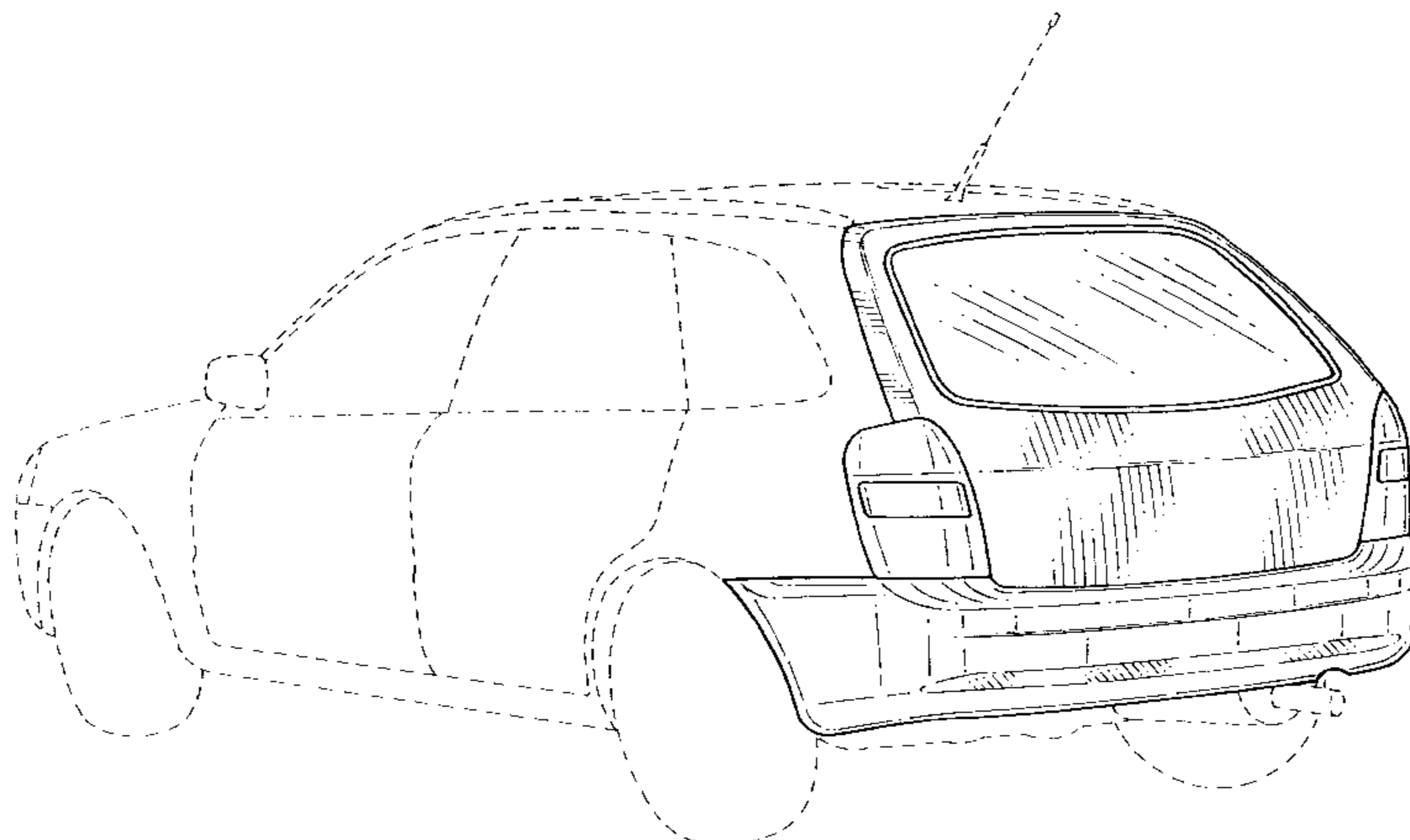
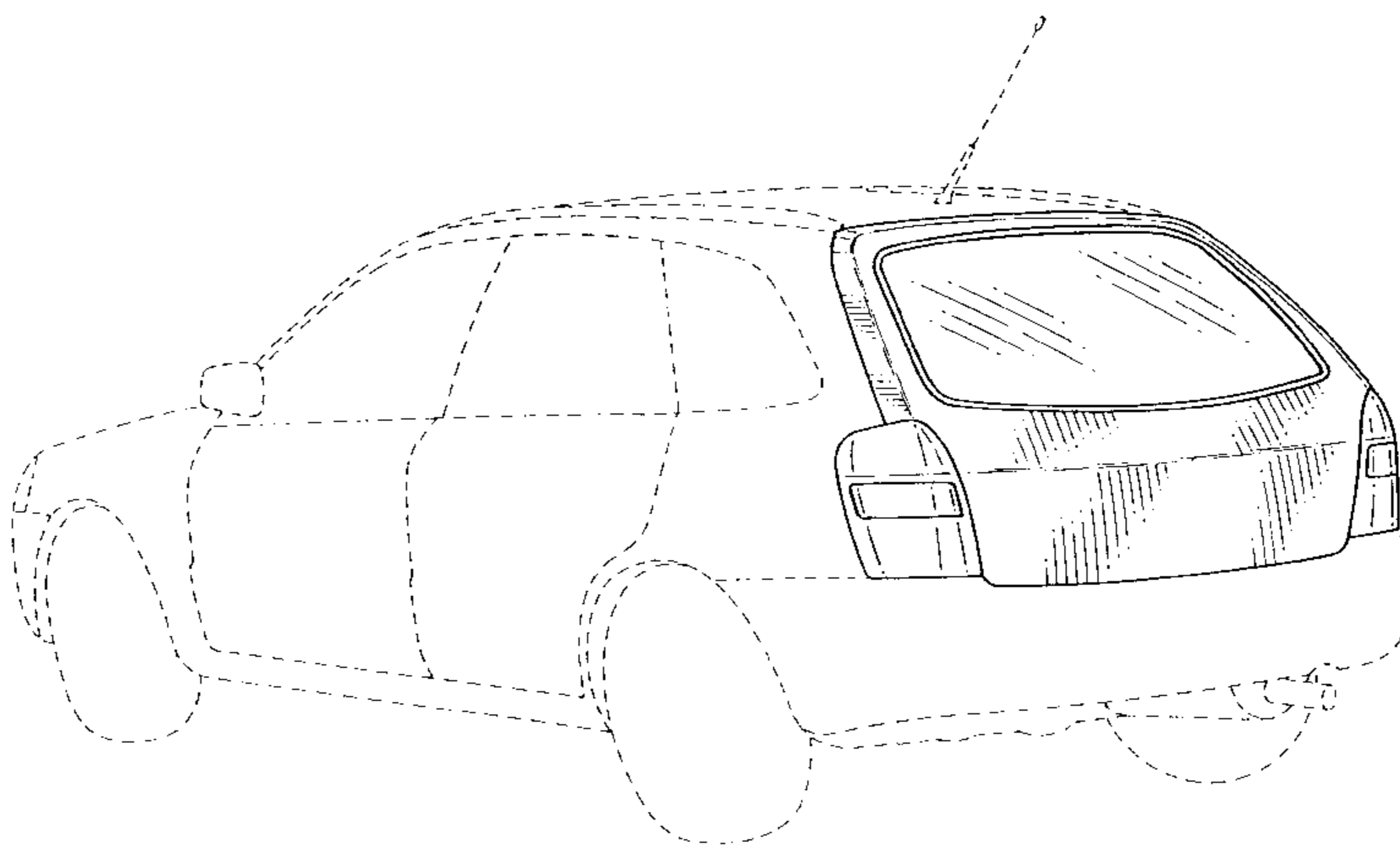

FIG. 1

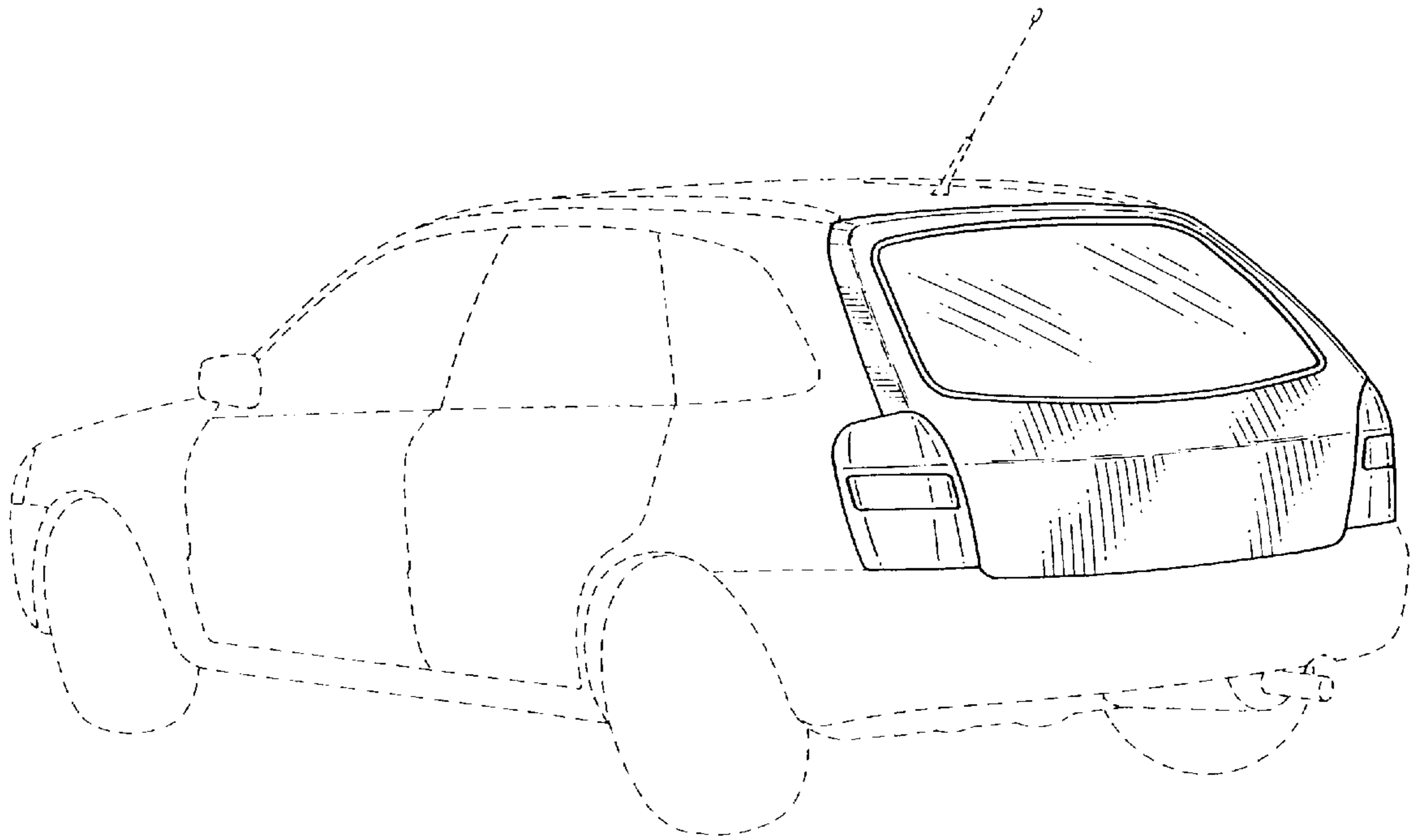

FIG. 2

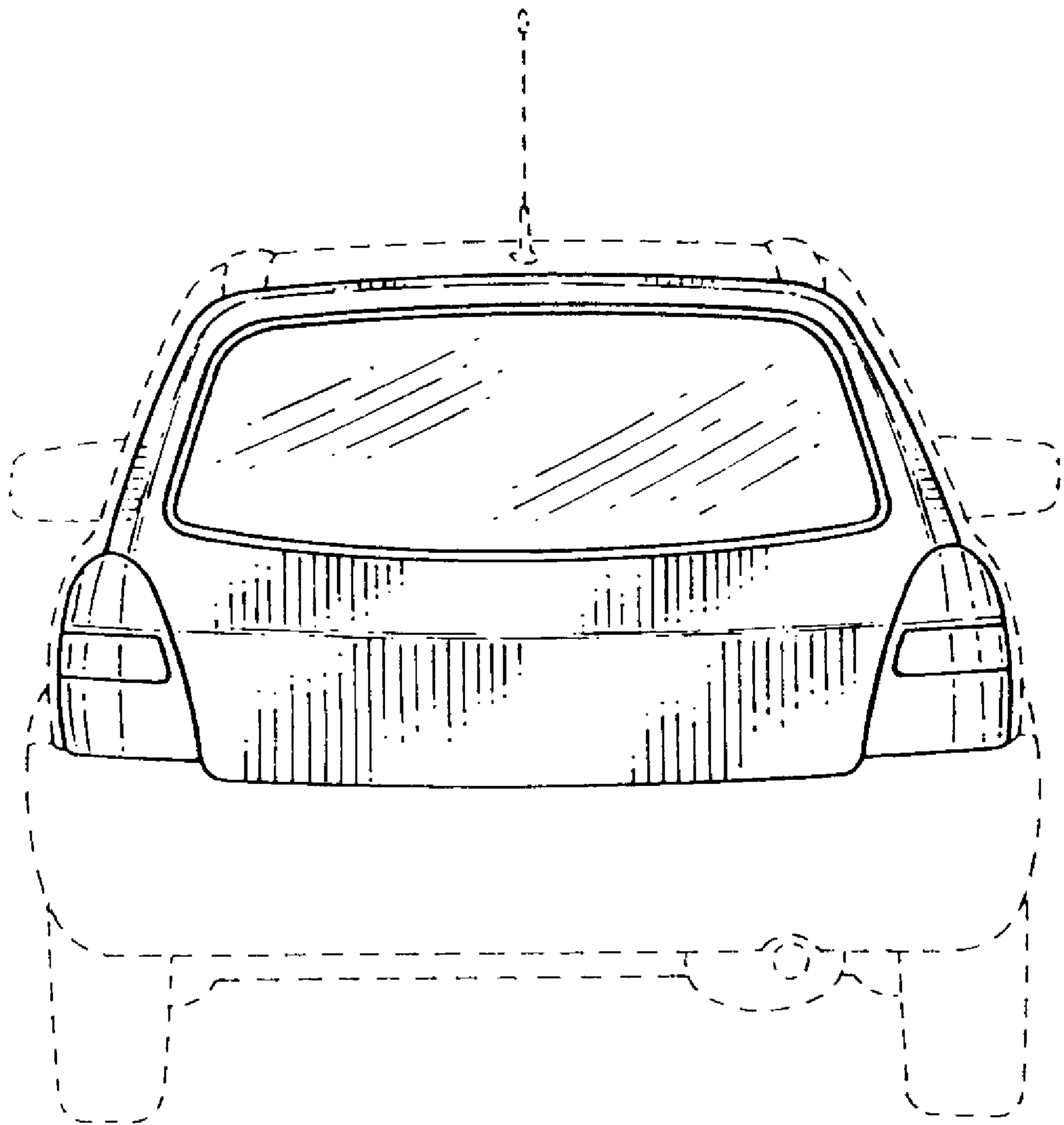

FIG. 3

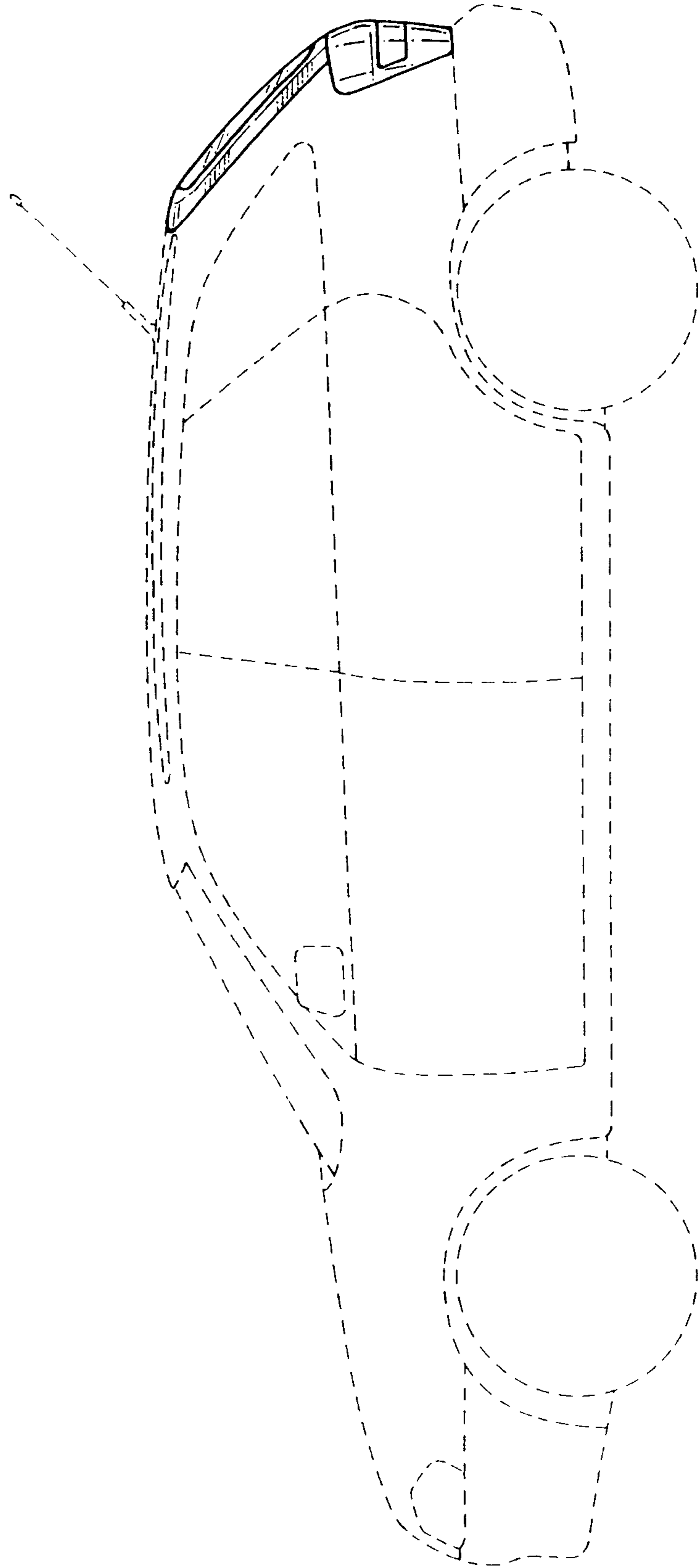

FIG. 4

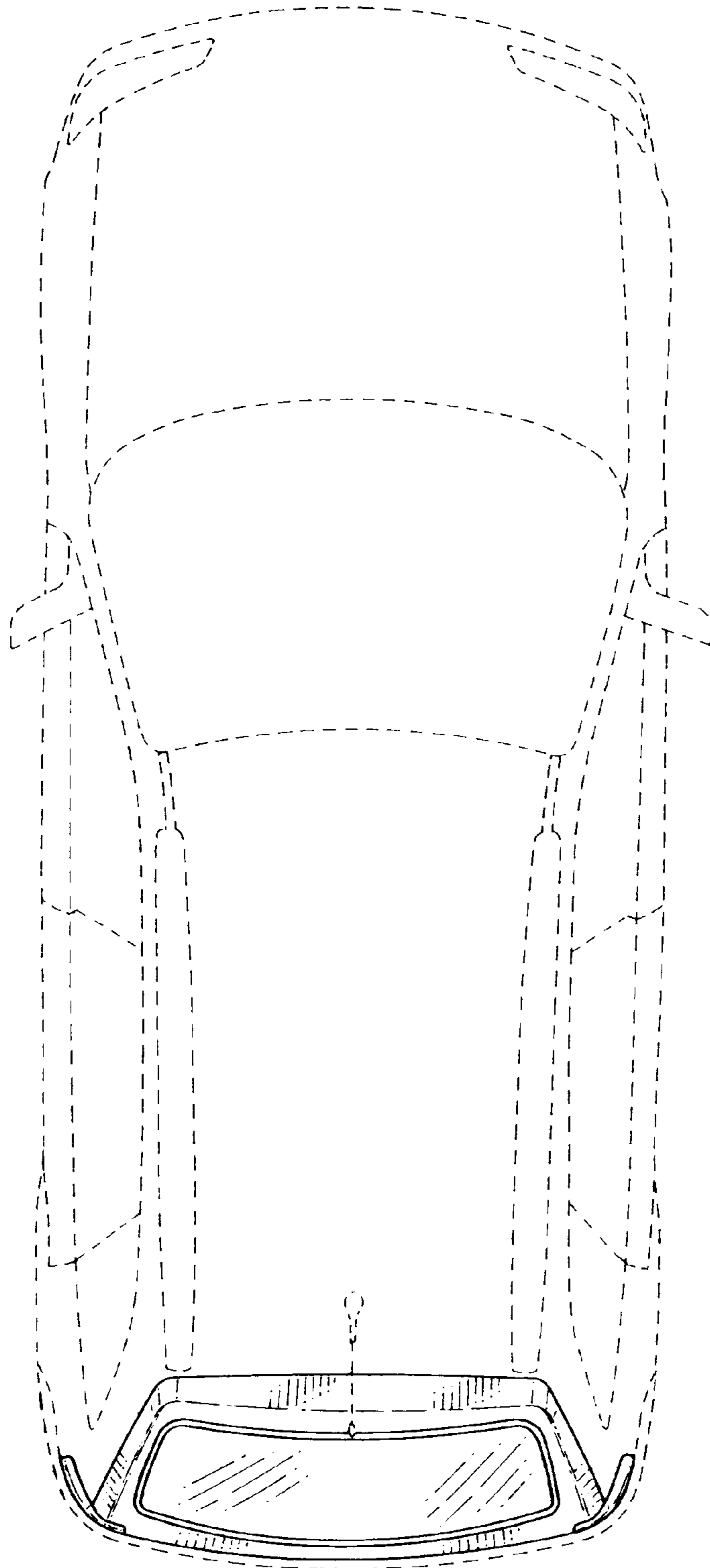

FIG. 5

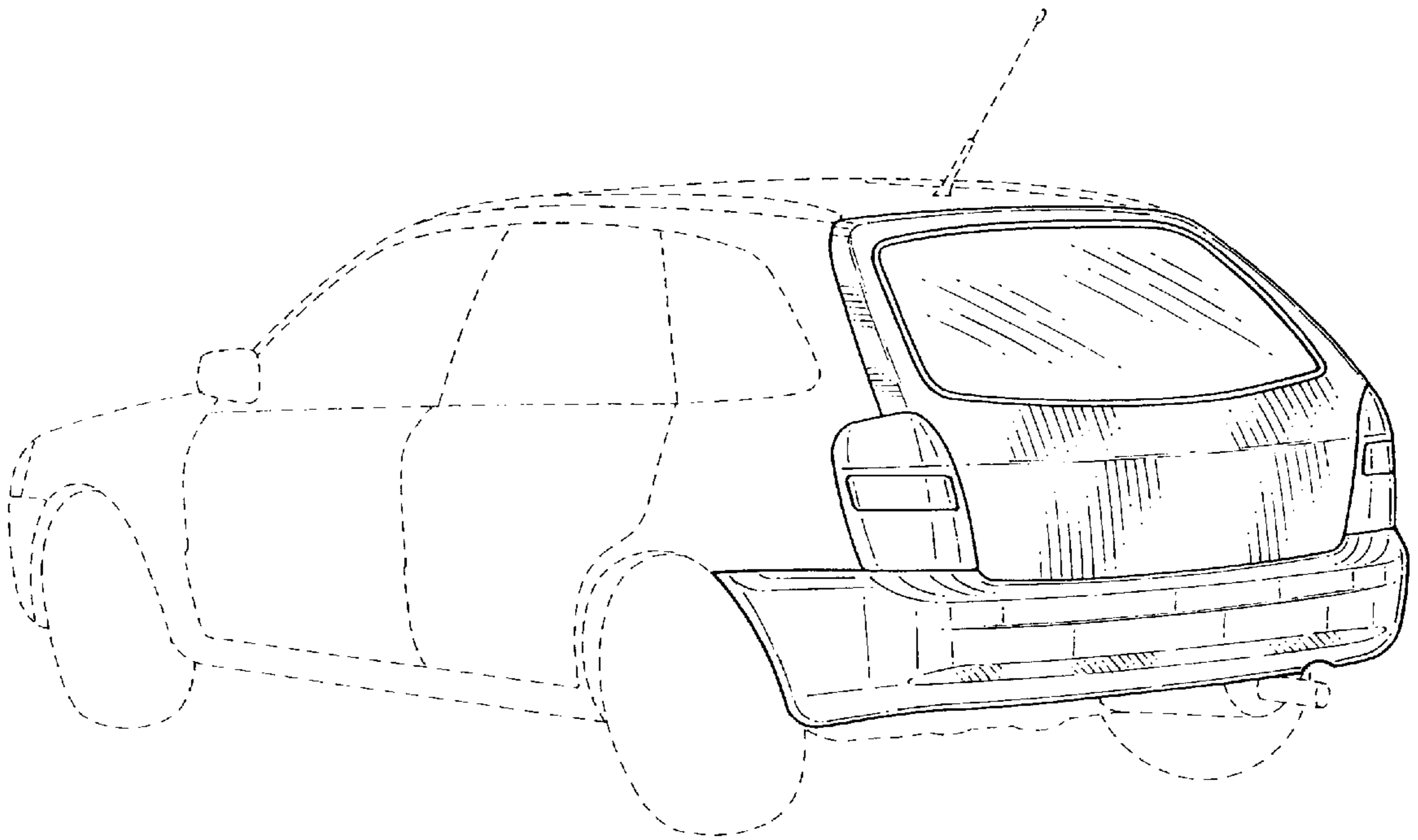

FIG. 6

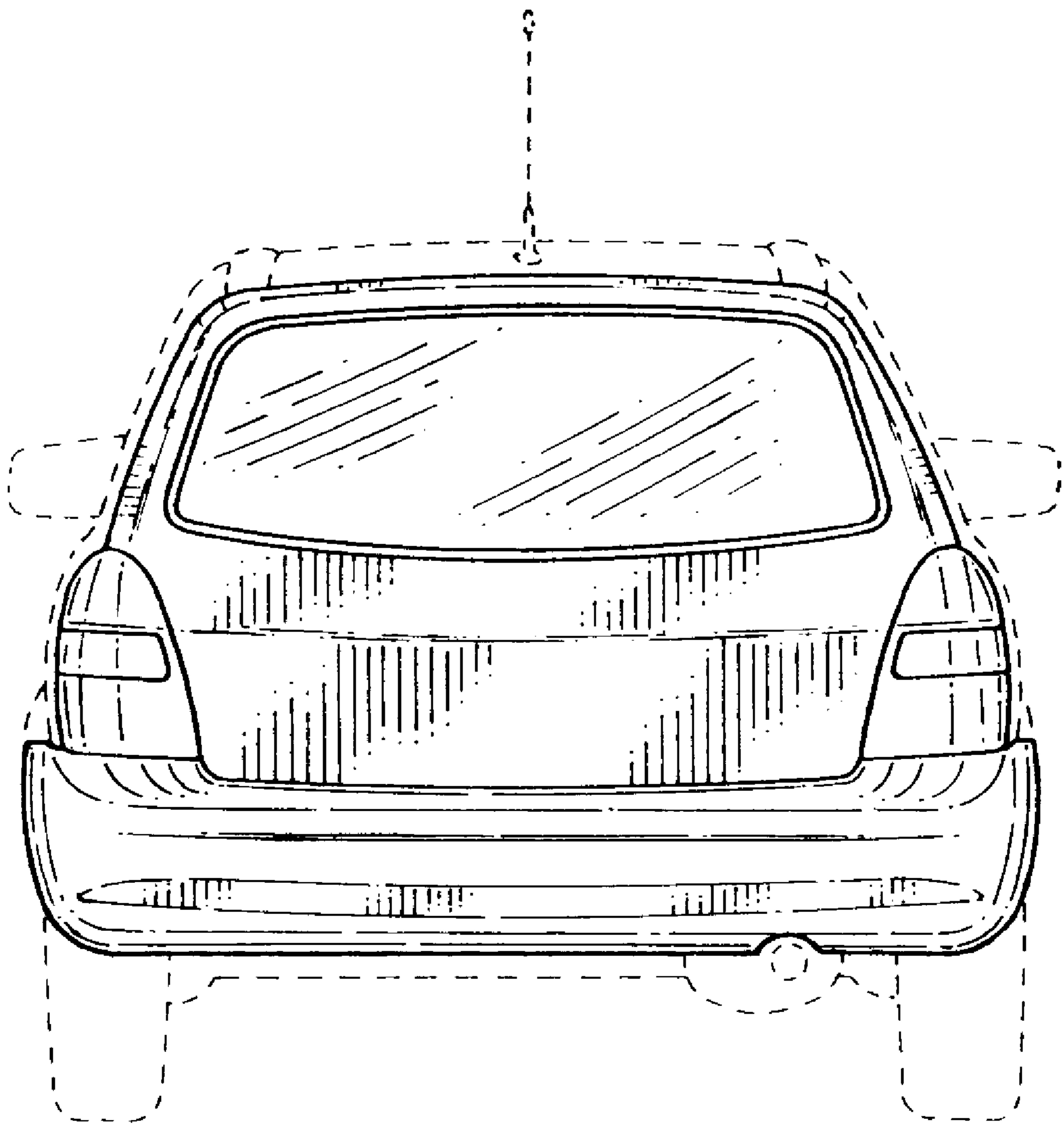

FIG. 7

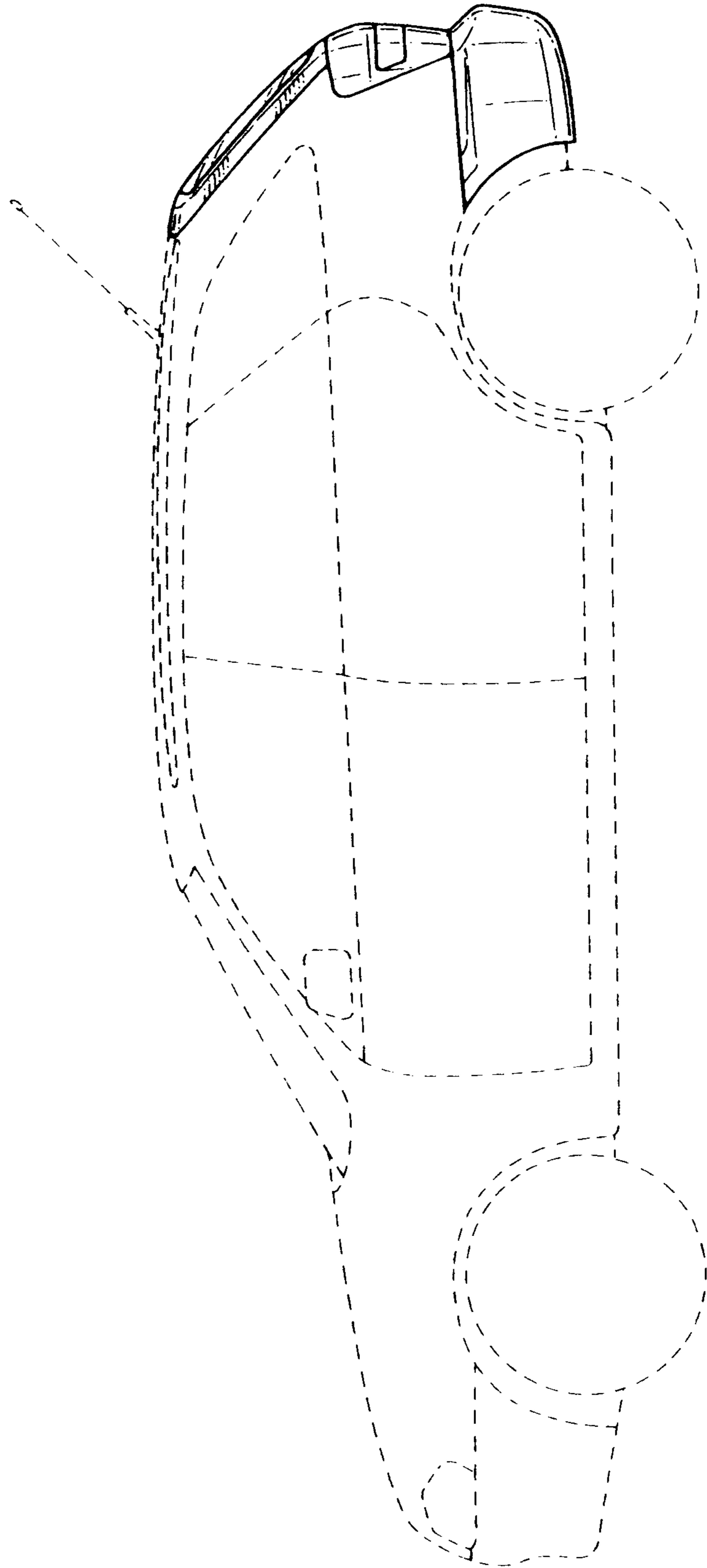

FIG. 8

