



US00D422251S

United States Patent [19]

Bader et al.

[11] Patent Number: **Des. 422,251**

[45] Date of Patent: **** Apr. 4, 2000**

[54] **COMBINED TRUCK HOOD AND FENDERS**

[75] Inventors: **Mark D. Bader**, Arlington; **Bryan W. Delashaw**, Frisco; **John F. Myers**; **Eric N. Tucker**, both of Denton, all of Tex.

[73] Assignee: **Paccar Inc**, Bellevue, Wash.

[**] Term: **14 Years**

[21] Appl. No.: **29/083,806**

[22] Filed: **Feb. 18, 1998**

[51] **LOC (6) Cl.** **12-16**

[52] **U.S. Cl.** **D12/173**

[58] **Field of Search** D12/173, 96; 180/69.2, 180/89.12, 89.13; 296/183, 190

[56] **References Cited**

U.S. PATENT DOCUMENTS

- D. 306,421 3/1990 Allendorph D12/173
- D. 306,714 3/1990 Allendorph D12/173
- D. 307,126 4/1990 Allendorph et al. D12/173
- D. 328,273 7/1992 McGrew, Jr. et al. D12/173
- D. 335,272 5/1993 Allendorph et al. D12/173

- D. 366,638 1/1996 Tucker et al. D12/173
- D. 367,027 2/1996 Onopa D12/173
- D. 382,841 8/1997 Norwood et al. D12/173
- D. 393,436 4/1998 William D12/173
- D. 401,198 11/1998 Wueller et al. D12/173

Primary Examiner—Melody N. Brown
Attorney, Agent, or Firm—Sidley & Austin

[57] **CLAIM**

The ornamental design for a combined truck hood and fenders, as shown and described.

DESCRIPTION

FIG. 1 is a perspective view of a combined truck hood and fenders showing our new design, it being understood that the broken lines are for illustrative purposes only and form no part of the claimed design;

FIG. 2 is a perspective view thereof having no broken lines;

FIG. 3 is a top view thereof;

FIG. 4 is a front view thereof;

FIG. 5 is a side view thereof; and,

FIG. 6 is the opposite side view thereof.

1 Claim, 4 Drawing Sheets

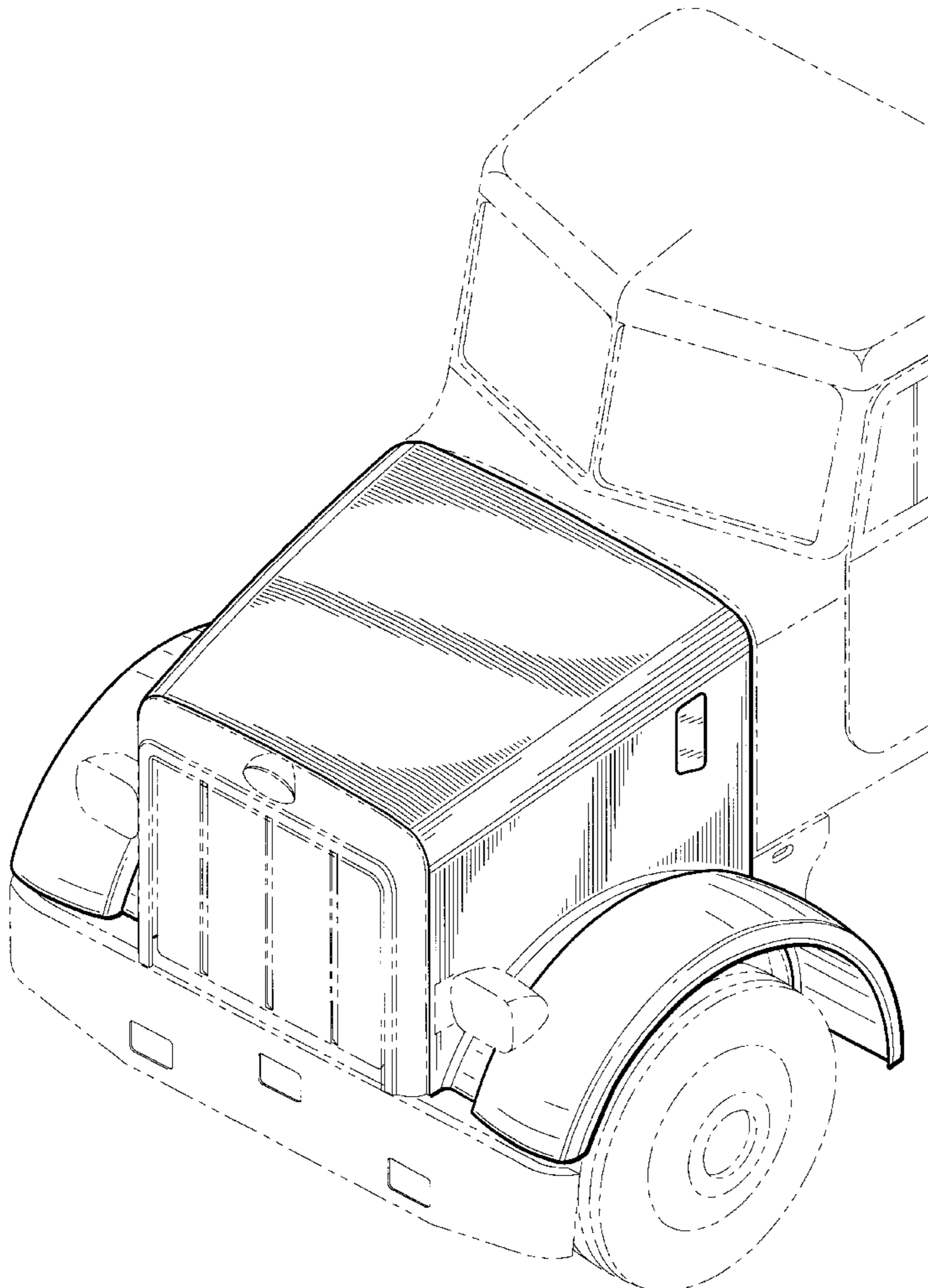

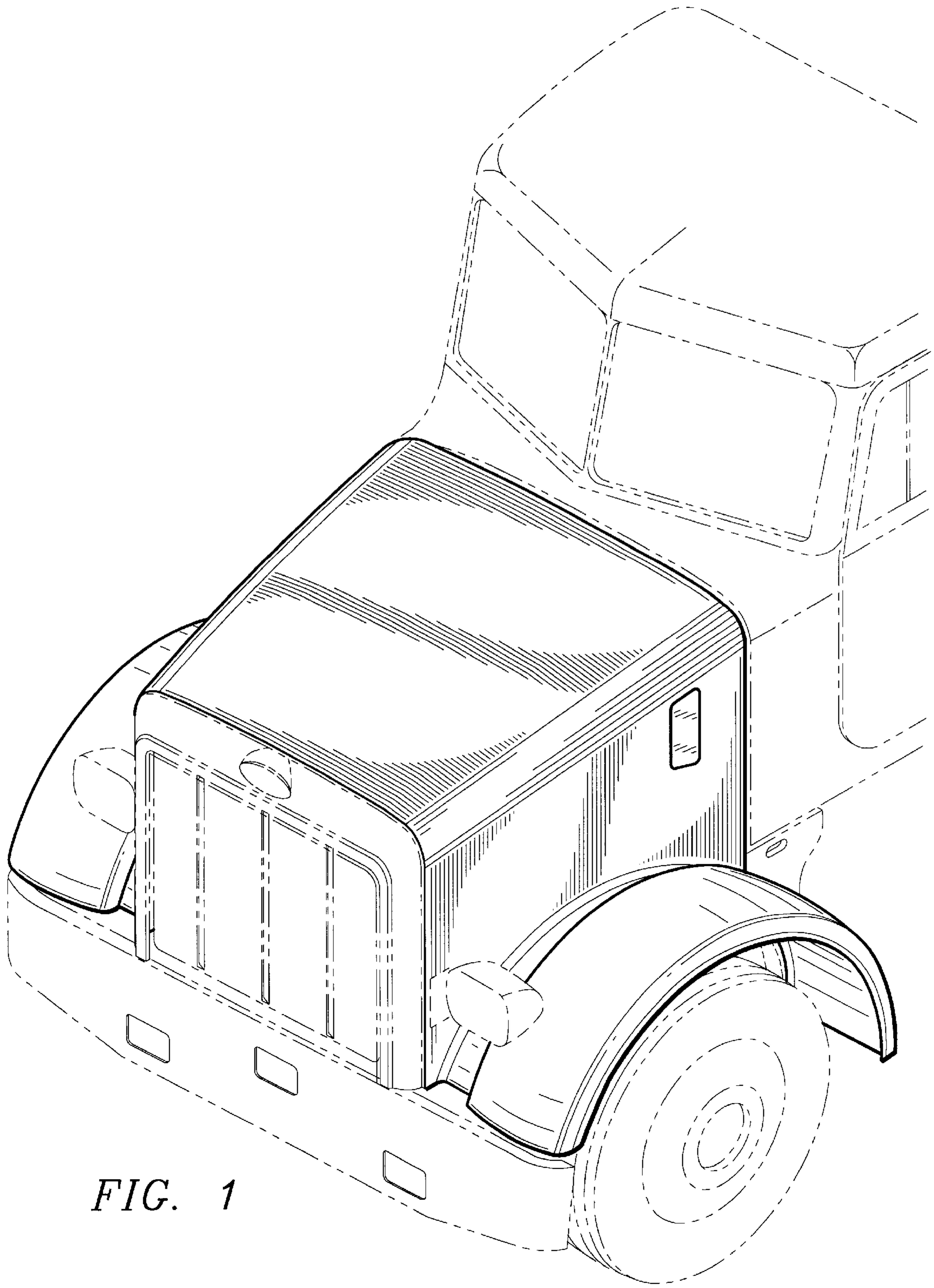

FIG. 1

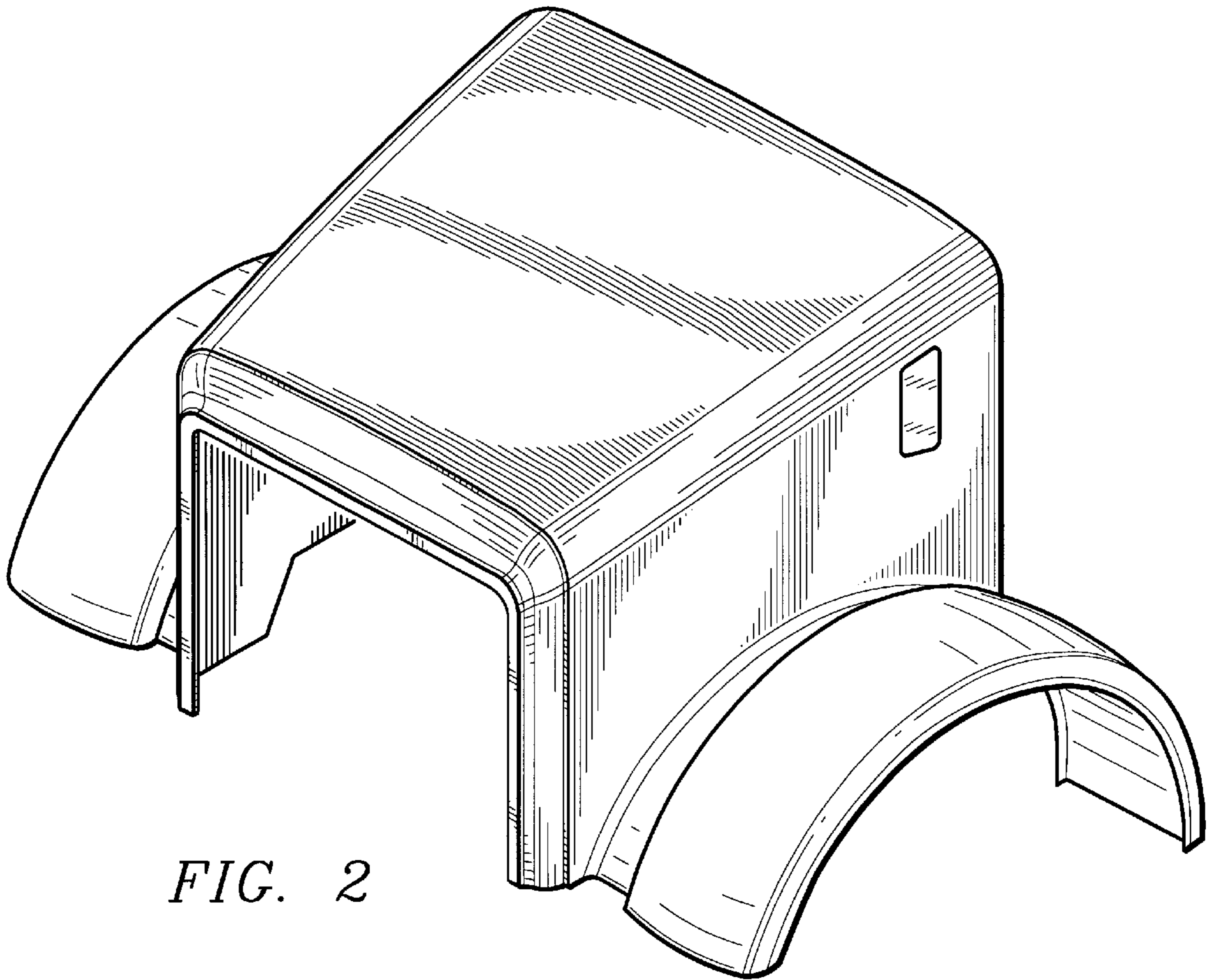

FIG. 2

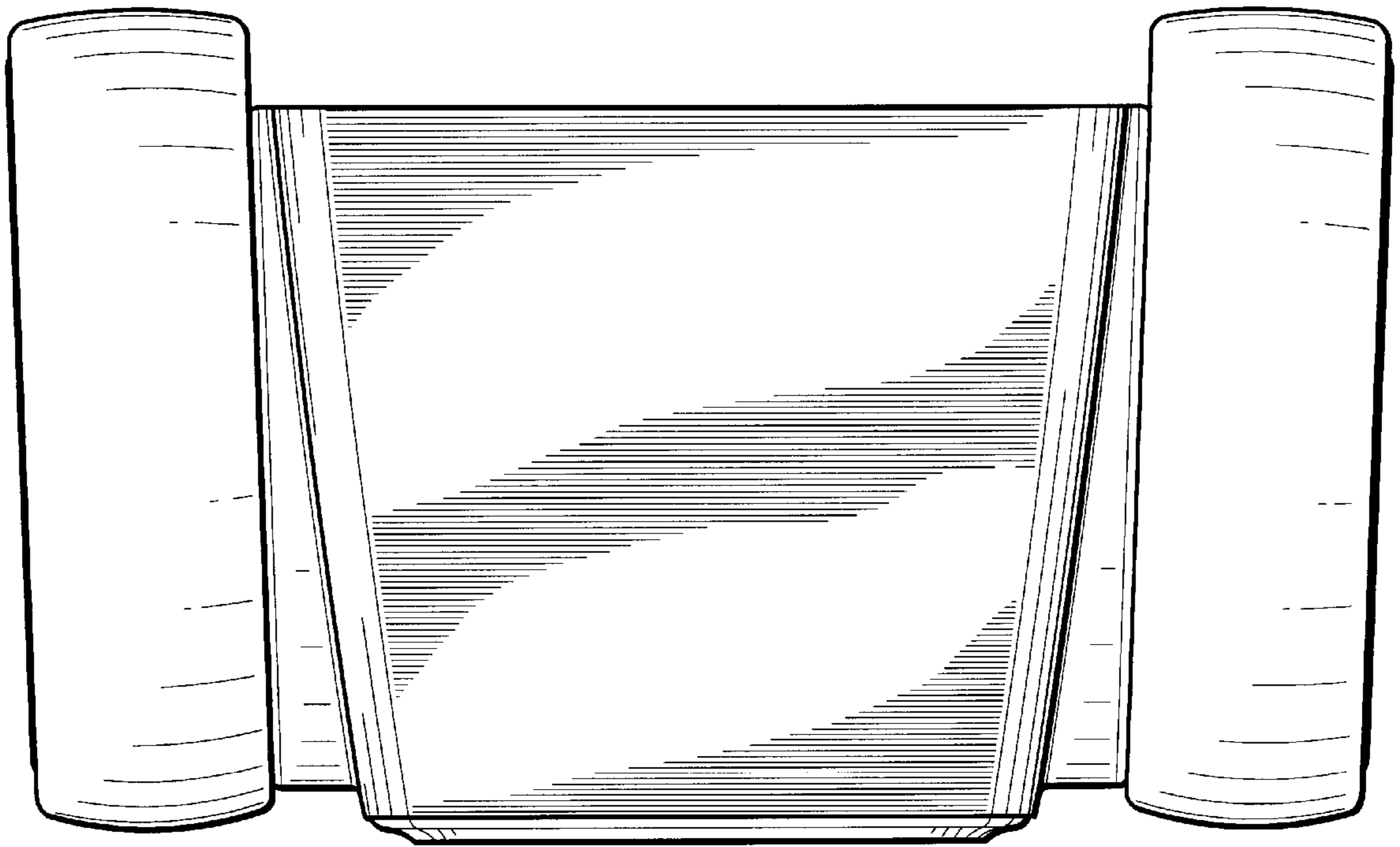

FIG. 3

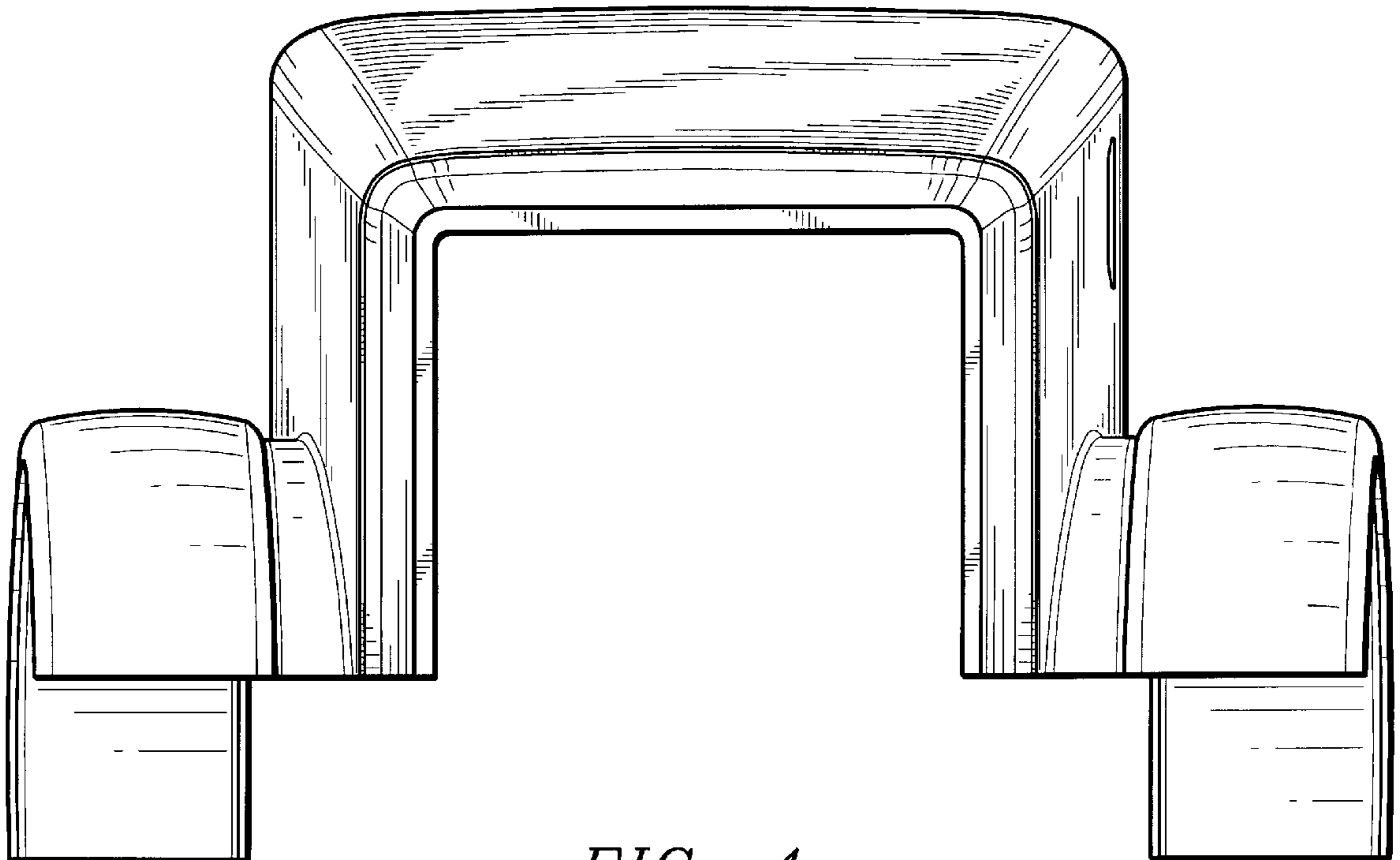

FIG. 4

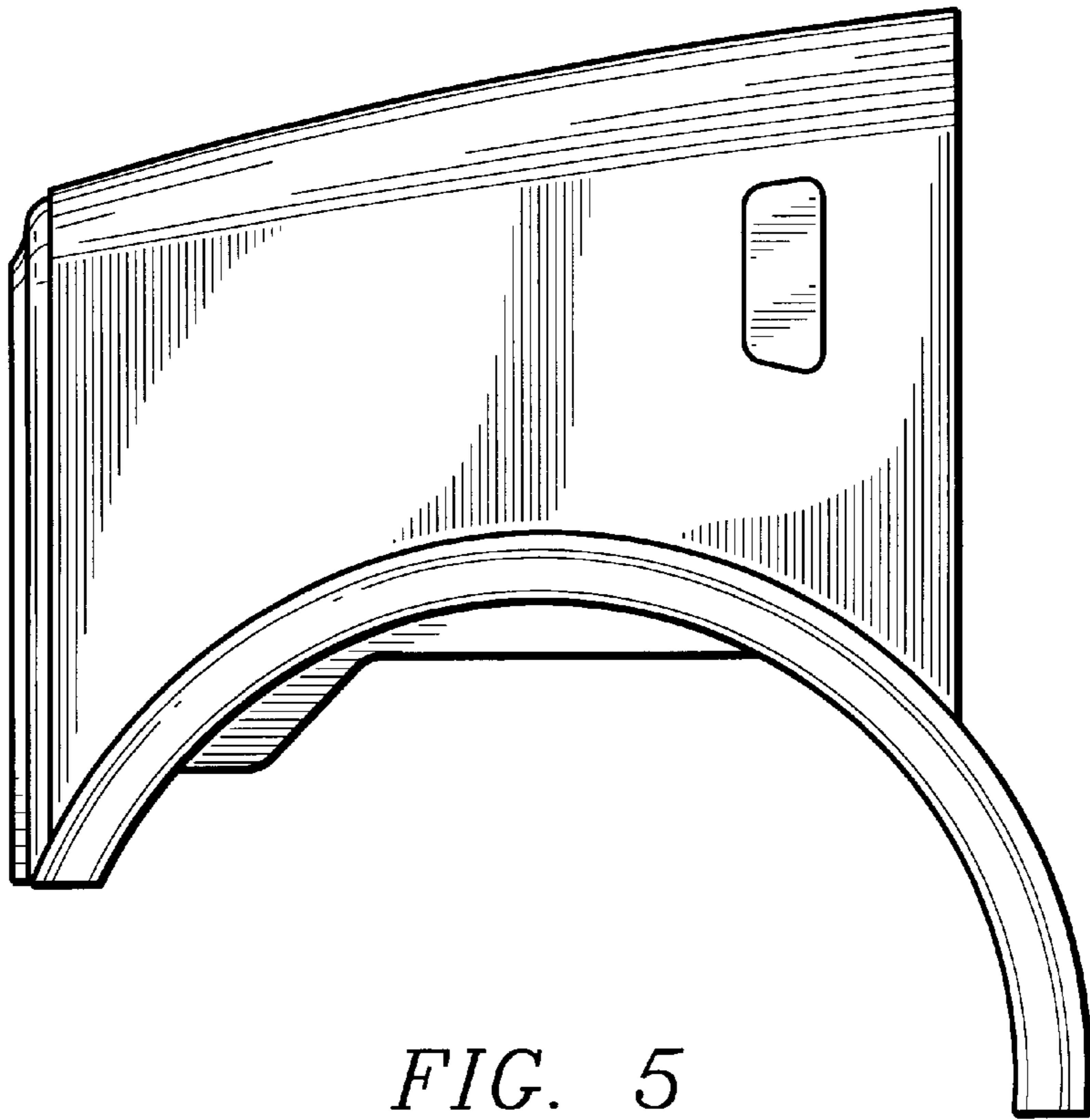

FIG. 5

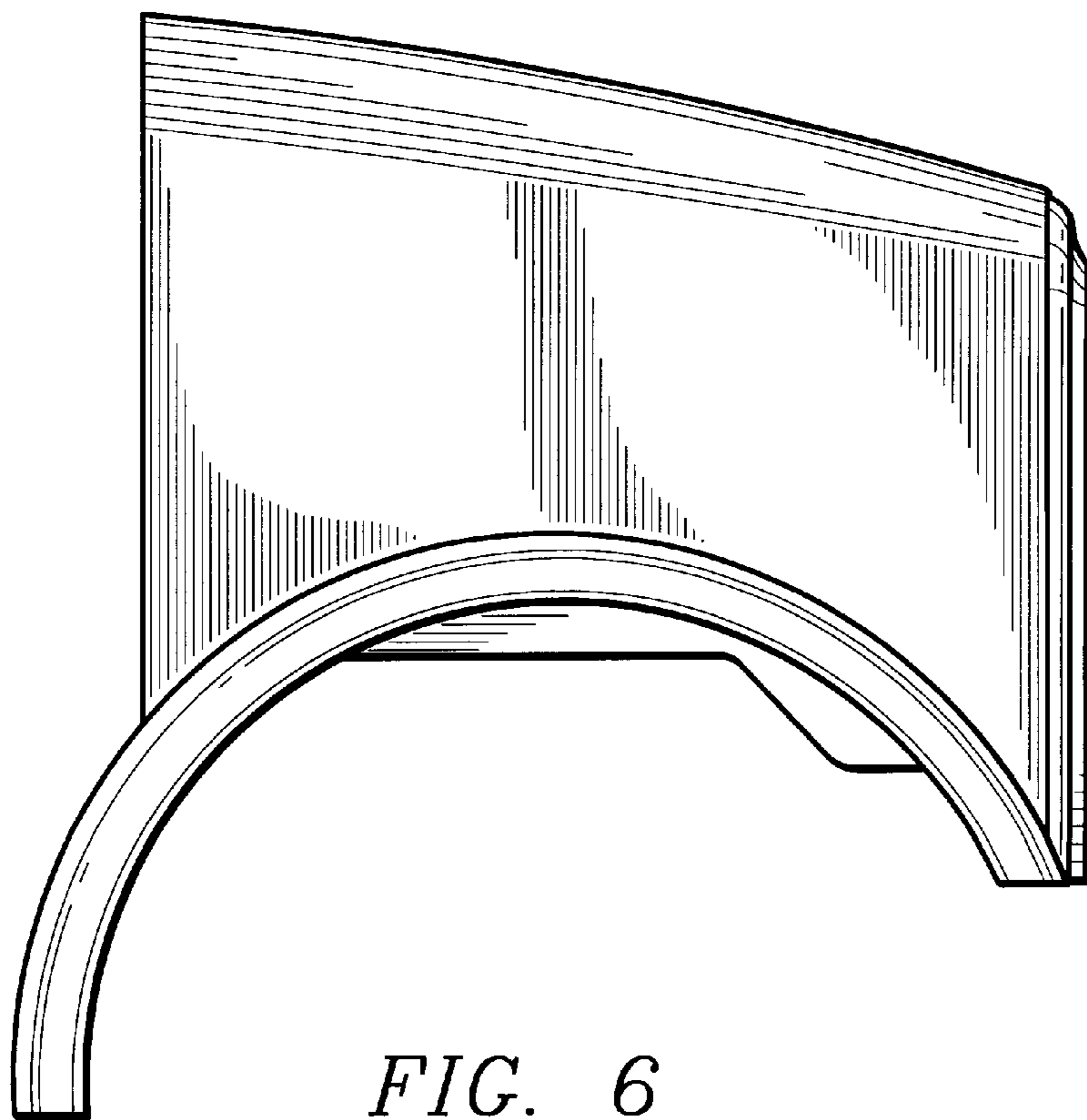

FIG. 6