



US00D422244S

United States Patent [19]

Heinrich et al.

[11] Patent Number: Des. 422,244

[45] Date of Patent: ** Apr. 4, 2000

[54] MOTORCYCLE

[75] Inventors: **Edgart Heinrich**, Freising; **David Robb**, München, both of Germany

[73] Assignee: **Bayerische Motoren Werke Aktiengesellschaft**, Munich, Germany

[**] Term: **14 Years**

[21] Appl. No.: **29/083,087**

[22] Filed: **Feb. 5, 1998**

[30] Foreign Application Priority Data

Aug. 5, 1997 [DE] Germany 97 07 122

[51] LOC (6) Cl. **12-11**

[52] U.S. Cl. **D12/110**

[58] Field of Search D12/110; 180/219

[56] References Cited

U.S. PATENT DOCUMENTS

D. 298,114	10/1988	Abe et al.	D12/110
D. 321,849	11/1991	Abe et al.	D12/110
D. 325,363	4/1992	Yamada et al.	D12/110
D. 341,798	11/1993	Murreta	D12/110
D. 350,918	9/1994	Kohoma	D12/110
D. 382,835	8/1997	Abe et al.	D12/110

D. 383,096 9/1997 Abe et al. D12/110

Primary Examiner—Melody N. Brown
Attorney, Agent, or Firm—Evenson, McKeown, Edwards & Lenahan, PLLC

[57] CLAIM

The ornamental design for a motorcycle, as shown and described.

DESCRIPTION

FIG. 1 is a front view of a motorcycle according to our novel design;
 FIG. 2 is a left side view of a motorcycle according to our novel design;
 FIG. 3 is a right side view of a motorcycle according to our novel design;
 FIG. 4 is a rear view of a motorcycle according to our novel design;
 FIG. 5 is a top view of a motorcycle according to our novel design;
 FIG. 6 is a perspective view from the front left side of a motorcycle according to our novel design; and,
 FIG. 7 is a perspective view from the rear left side of a motorcycle according to our novel design.
 The broken line showing depicts environment and is not part of the claimed design.

1 Claim, 6 Drawing Sheets

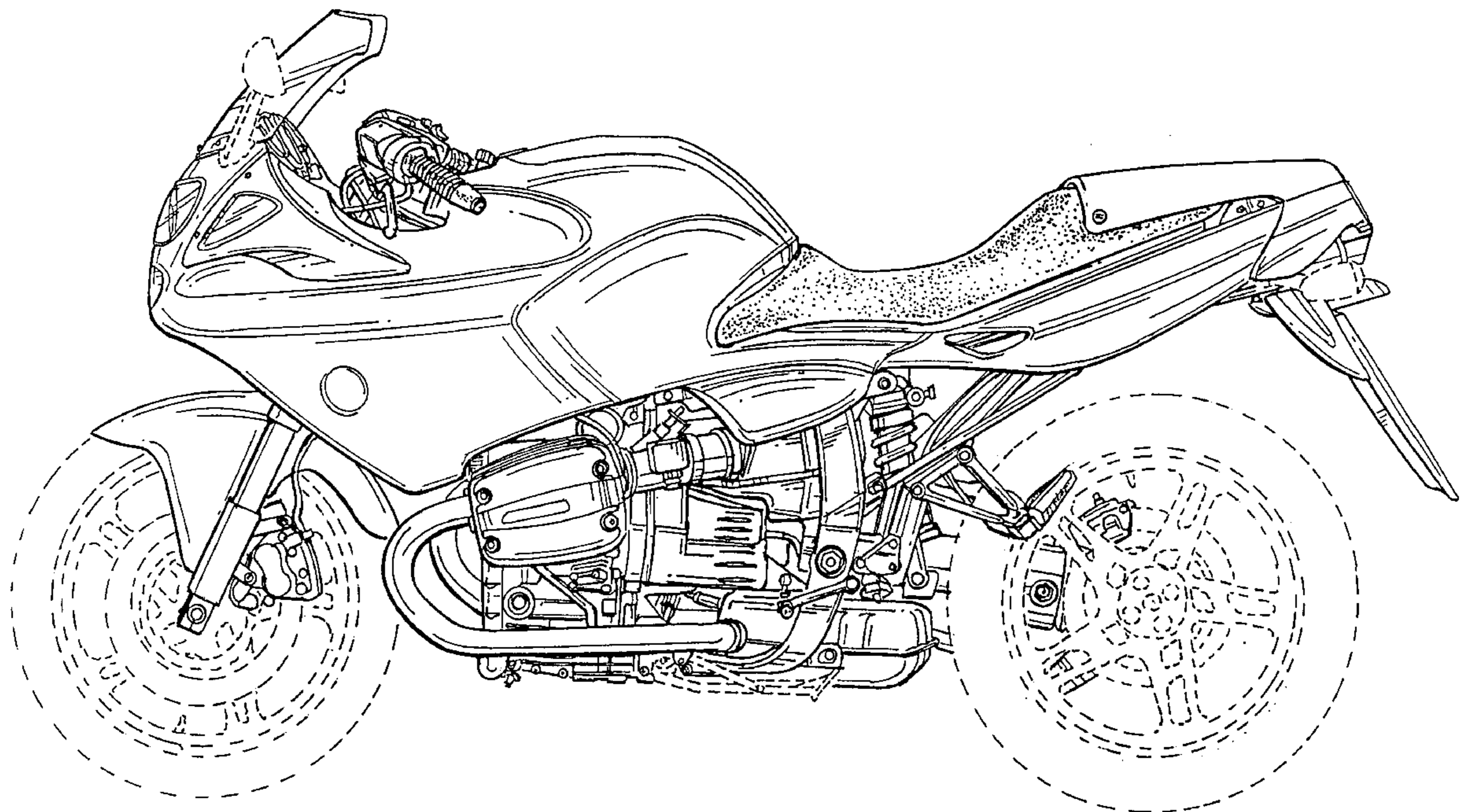

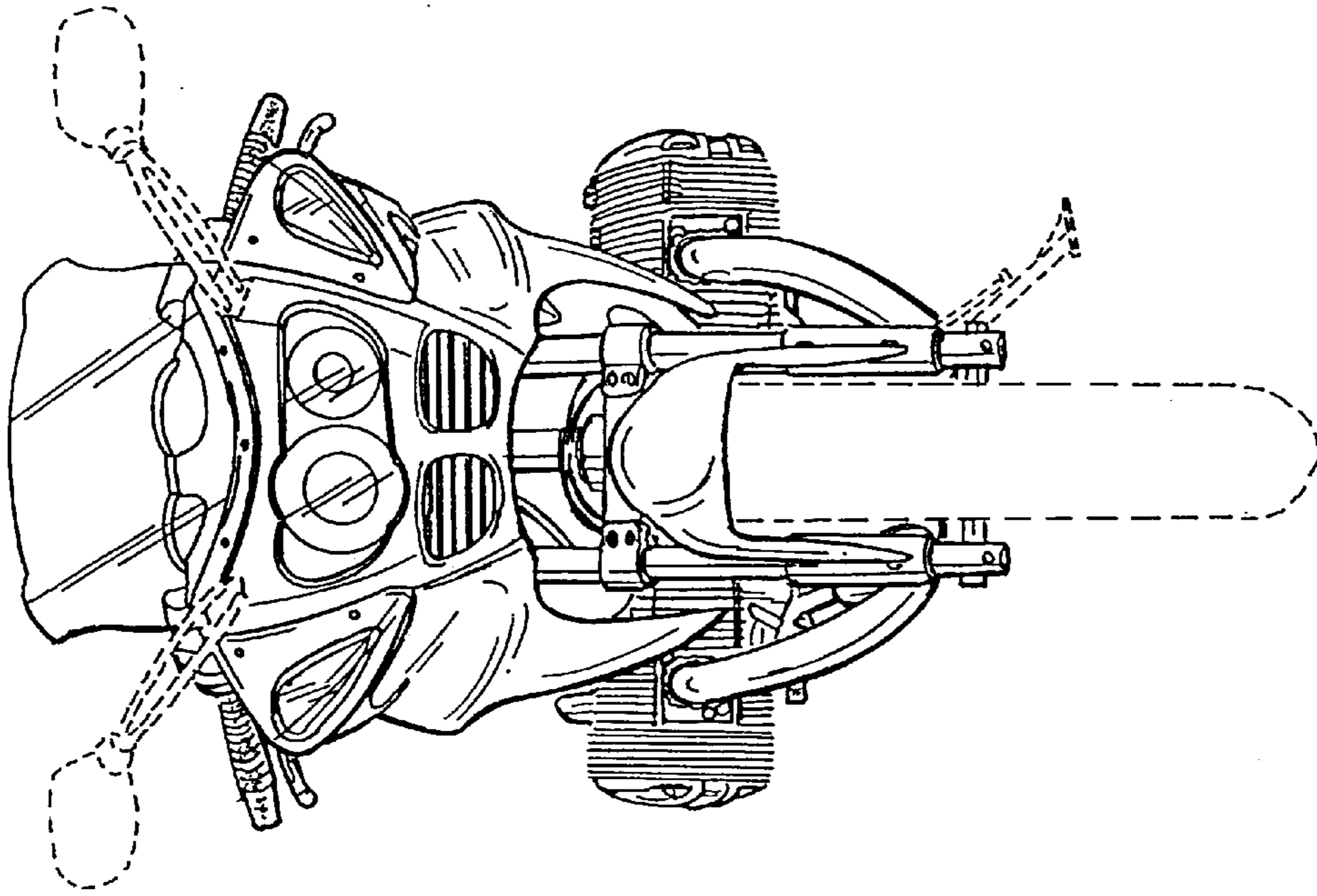

FIG. 1

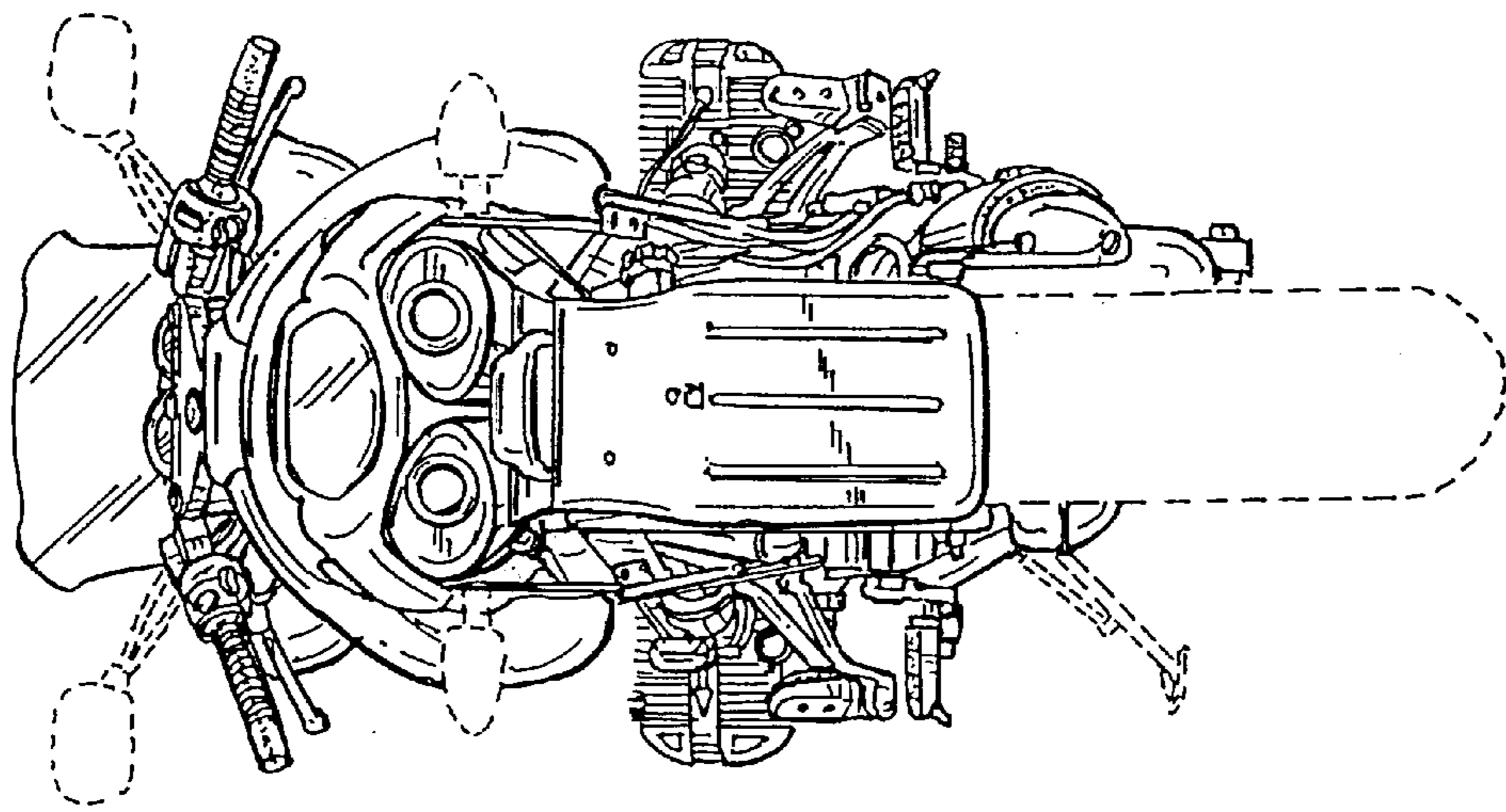

FIG. 4

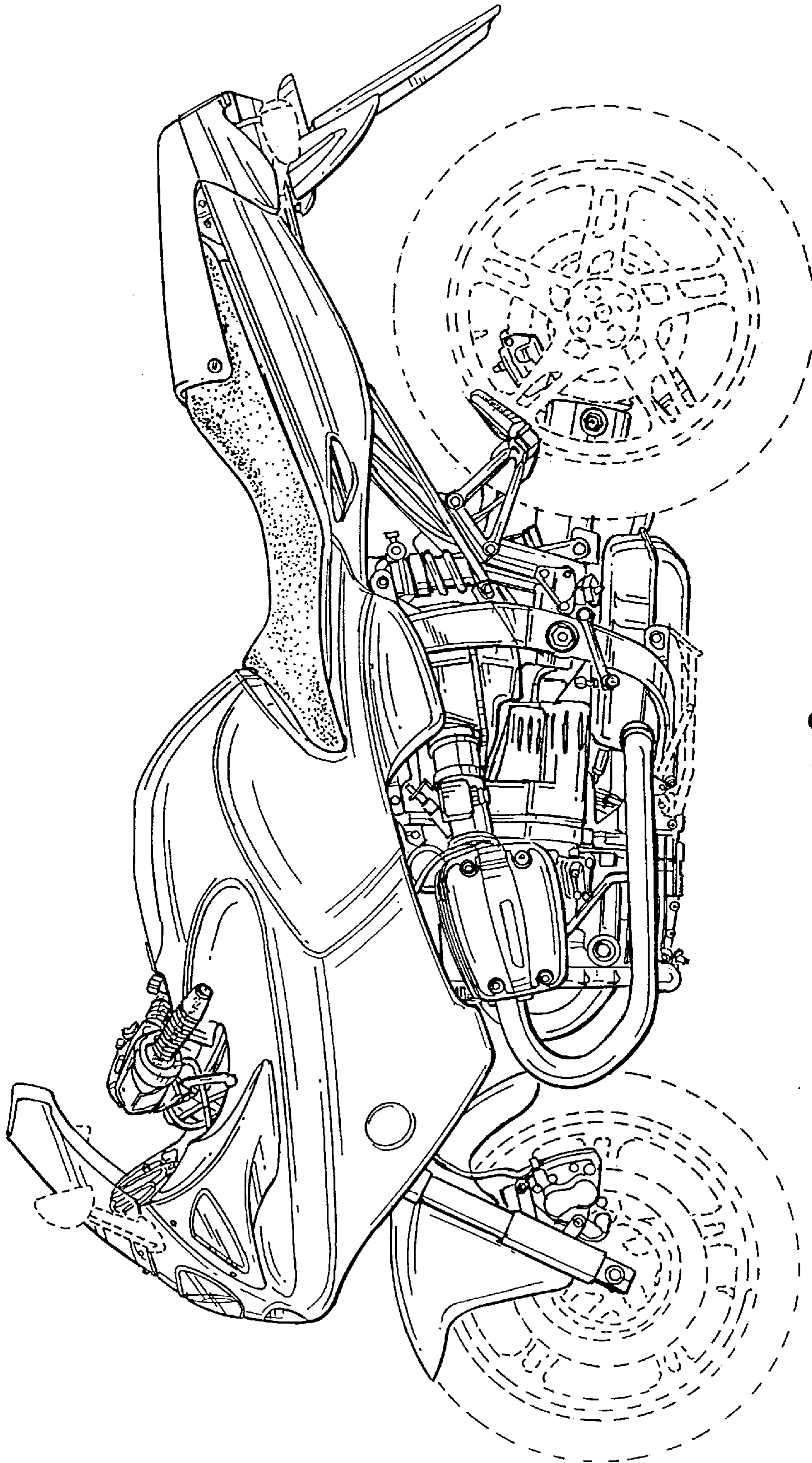

FIG. 2

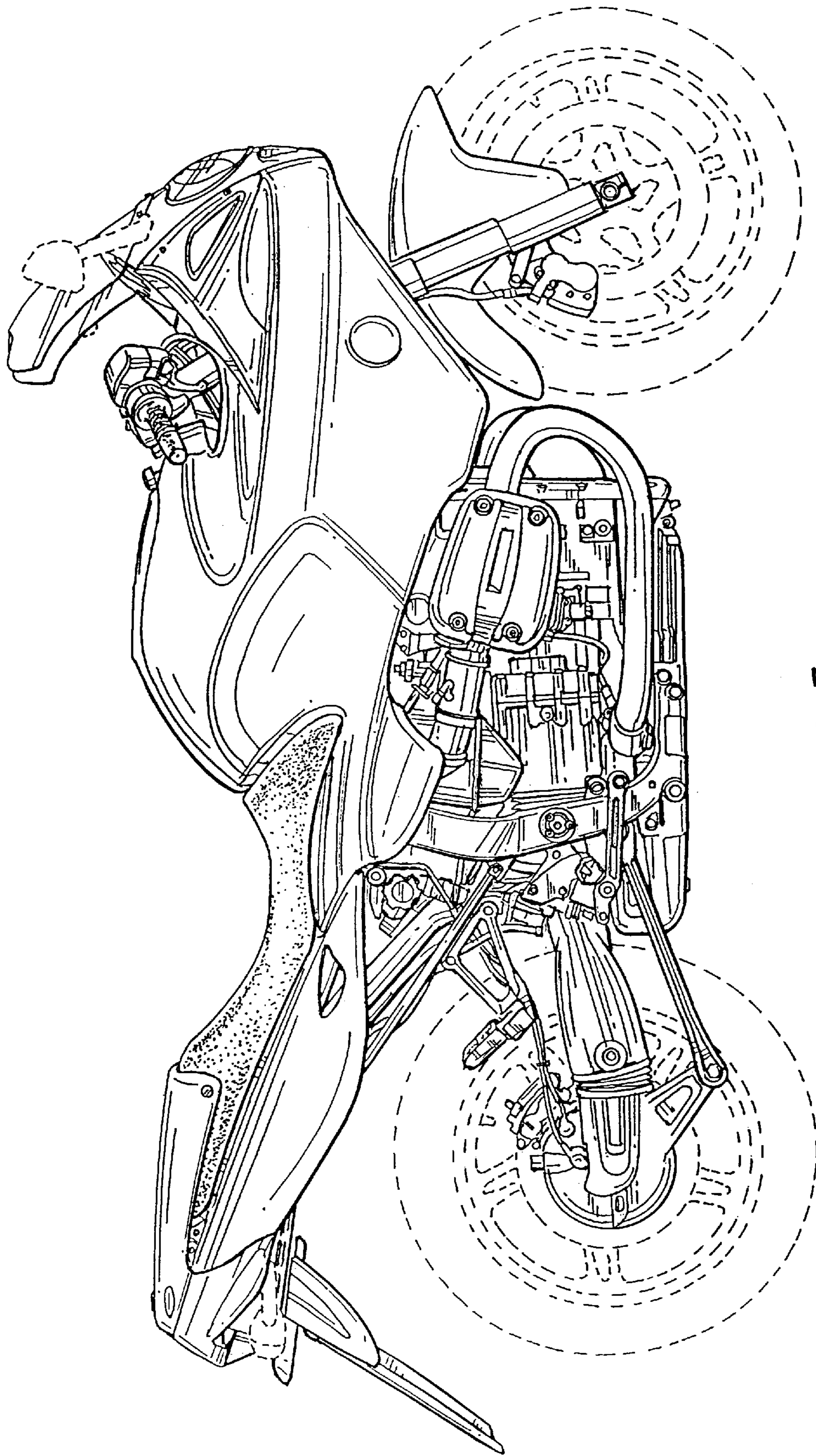

FIG. 3

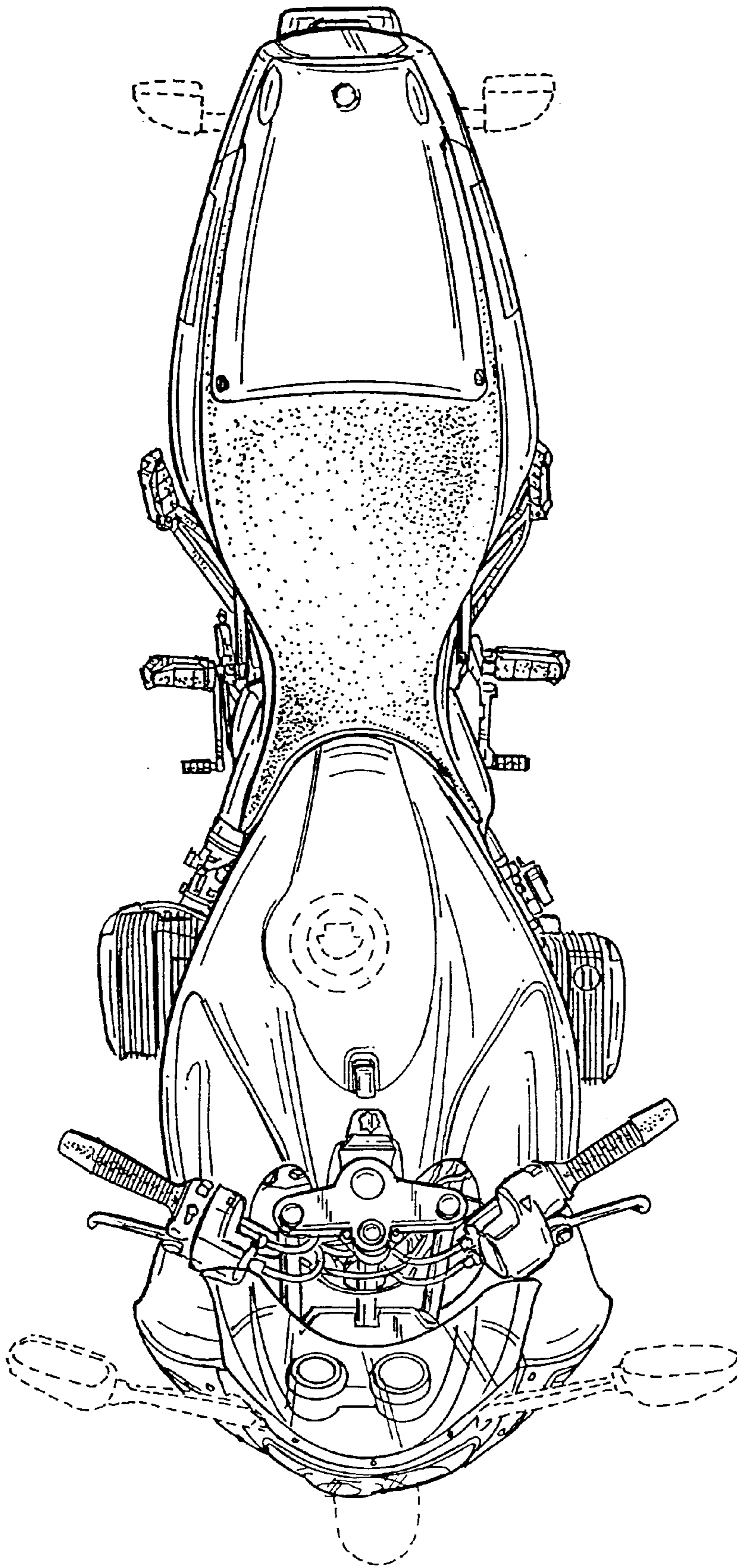

FIG. 5

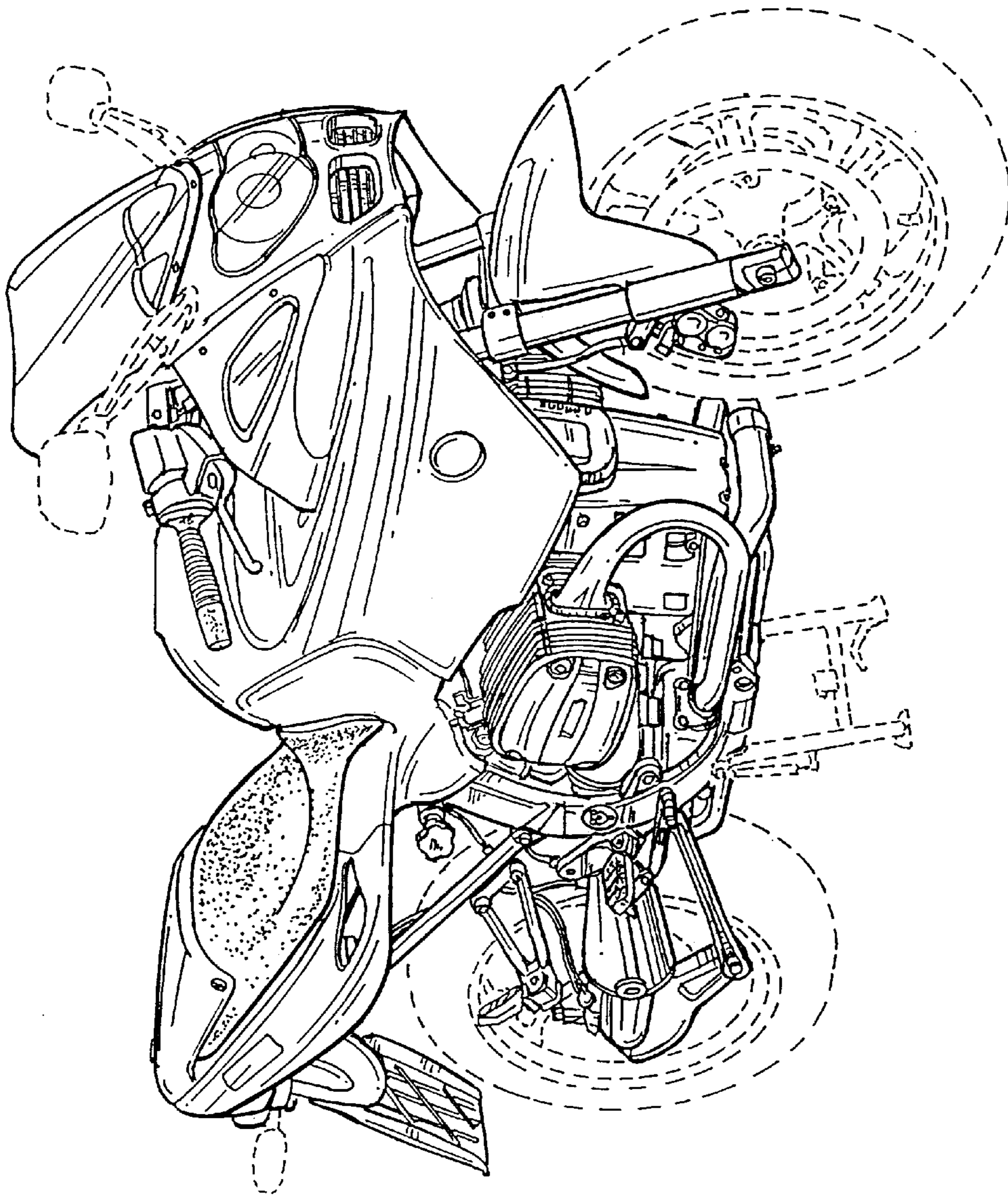

FIG. 6

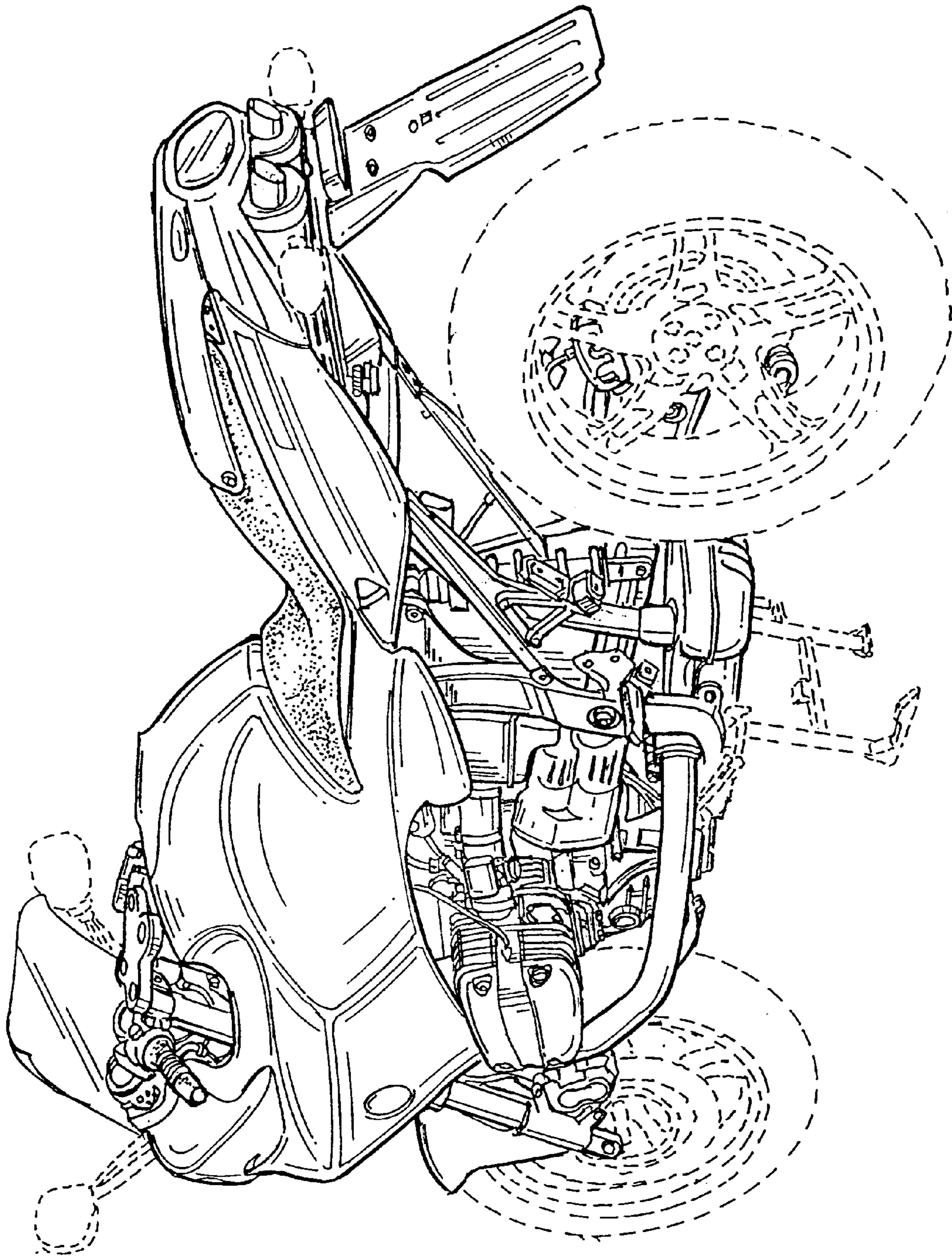

FIG. 7