



US00D421949S

**United States Patent** [19]  
**Shimazu**

[11] **Patent Number: Des. 421,949**  
[45] **Date of Patent: \*\* Mar. 28, 2000**

[54] **REAR PORTION OF A MOTOR VEHICLE**

[75] Inventor: **Yutaka Shimazu**, Aki-gun, Japan

[73] Assignee: **Mazda Motor Corporation**,  
Hiroshima-ken, Japan

[\*\*] Term: **14 Years**

[21] Appl. No.: **29/102,381**

[22] Filed: **Mar. 24, 1999**

[51] **LOC (6) Cl.** ..... **12-16**

[52] **U.S. Cl.** ..... **D12/196**

[58] **Field of Search** ..... D12/196, 90-92;  
296/185

[56] **References Cited**

**U.S. PATENT DOCUMENTS**

- D. 395,259 6/1998 Ohsawa et al. .... D12/91
- D. 395,619 6/1998 Cho ..... D12/91
- D. 406,795 3/1999 Nagula et al. .... D12/91

**OTHER PUBLICATIONS**

Bulletin Des Dessins Et Modeles Internationaus (International Designs Bulletin) Aug. 1994, Depot No. DM/030 569 dated Apr. 13, 1994 in the name of Fiat Auto S.P.A., pp. 4529-4530 and 4539-4540.

*Primary Examiner*—Melody N. Brown  
*Attorney, Agent, or Firm*—Sidley & Austin; Hugh A. Abrams

[57] **CLAIM**

The ornamental design for a rear portion of a motor vehicle, as shown and described.

**DESCRIPTION**

FIG. 1 is a perspective view of a rear portion of a motor vehicle;  
 FIG. 2 is a front view of the first rear portion;  
 FIG. 3 is a front view of the motor vehicle;  
 FIG. 4 is a left side view of the first rear portion;  
 FIG. 5 is a right side view of the first rear portion;  
 FIG. 6 is a top view of the first rear portion;  
 FIG. 7 is a perspective view of a second embodiment of a rear portion of a motor vehicle;  
 FIG. 8 is a front view of the second rear portion;  
 FIG. 9 is a front view of the motor vehicle;  
 FIG. 10 is a left side view of the second rear portion;  
 FIG. 11 is a right side view of the second rear poistion;  
 FIG. 12 is a top view of the second rear portion;  
 FIG. 13 is a perspective view of a third embodiment of a motor vehicle;  
 FIG. 14 is a front view of the third rear portion;  
 FIG. 15 is a front view of the motor vehicle;  
 FIG. 16 is a left side view of the third rear portion;  
 FIG. 17 is a right side view of the third rear portion; and,  
 FIG. 18 is a top view of the third rear portion.

The portion of the motor vehicle shown in broken lines is for illustrative purpose only and forms no part of the claimed design.

**1 Claim, 15 Drawing Sheets**

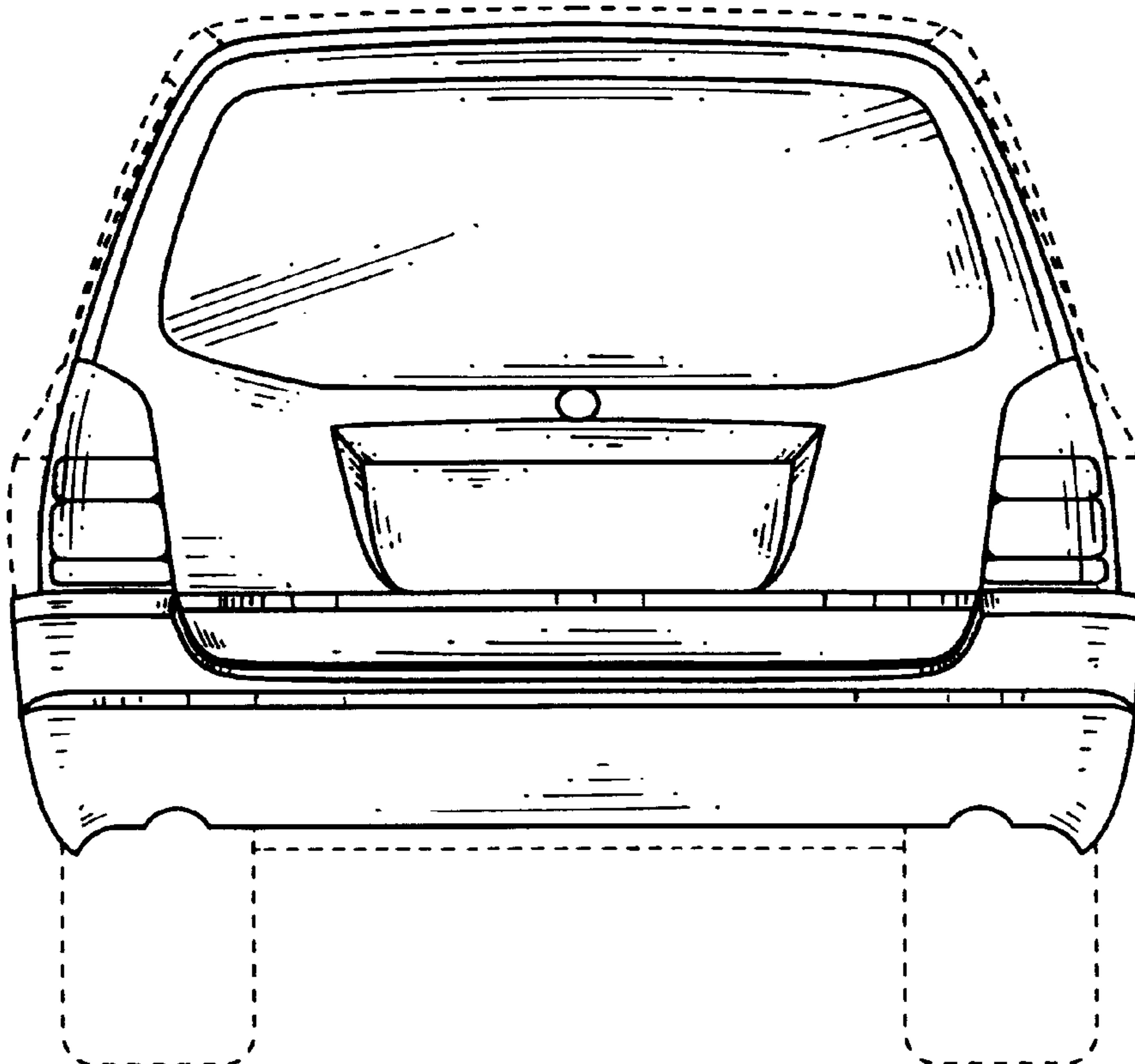

FIG. 1

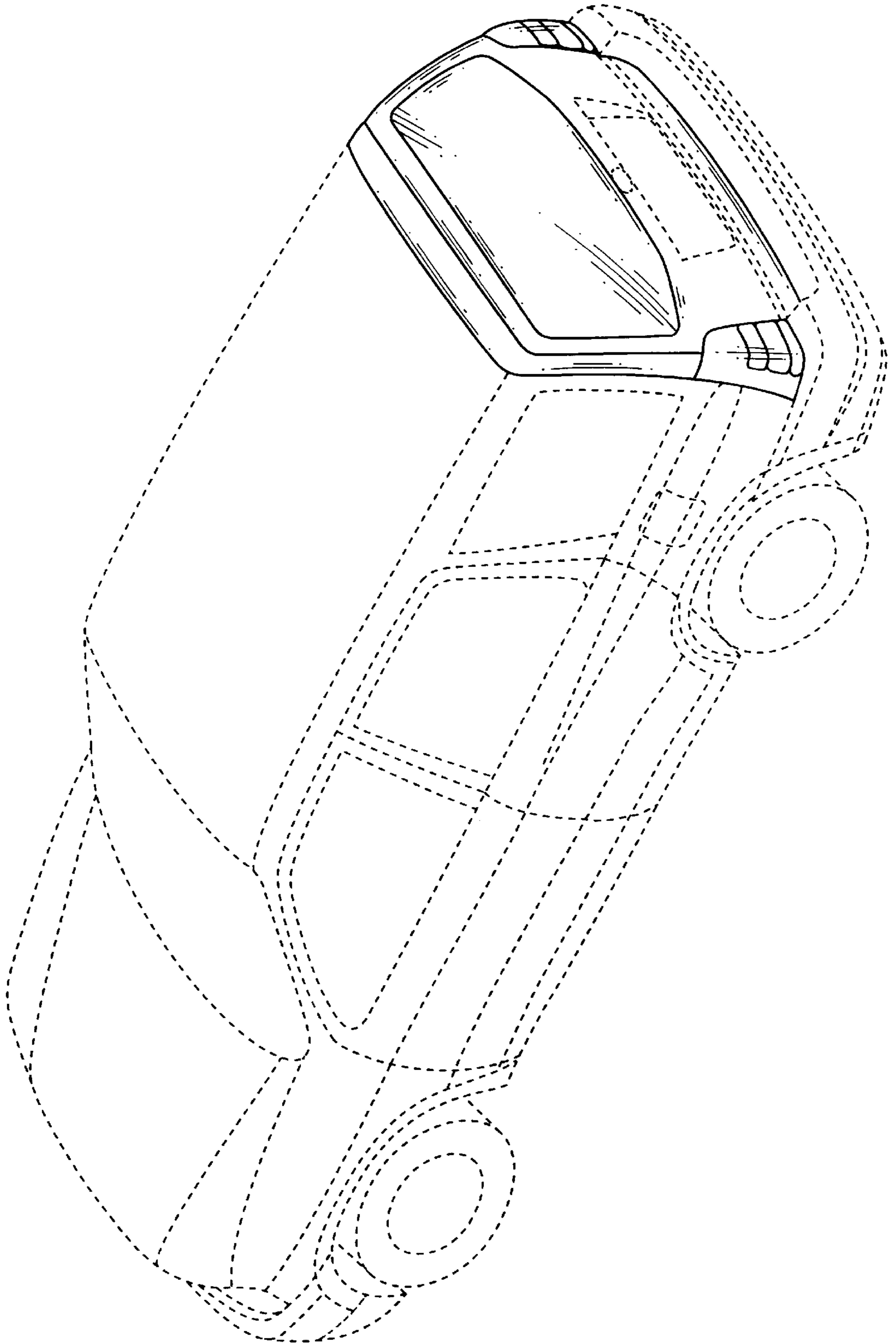

FIG. 2

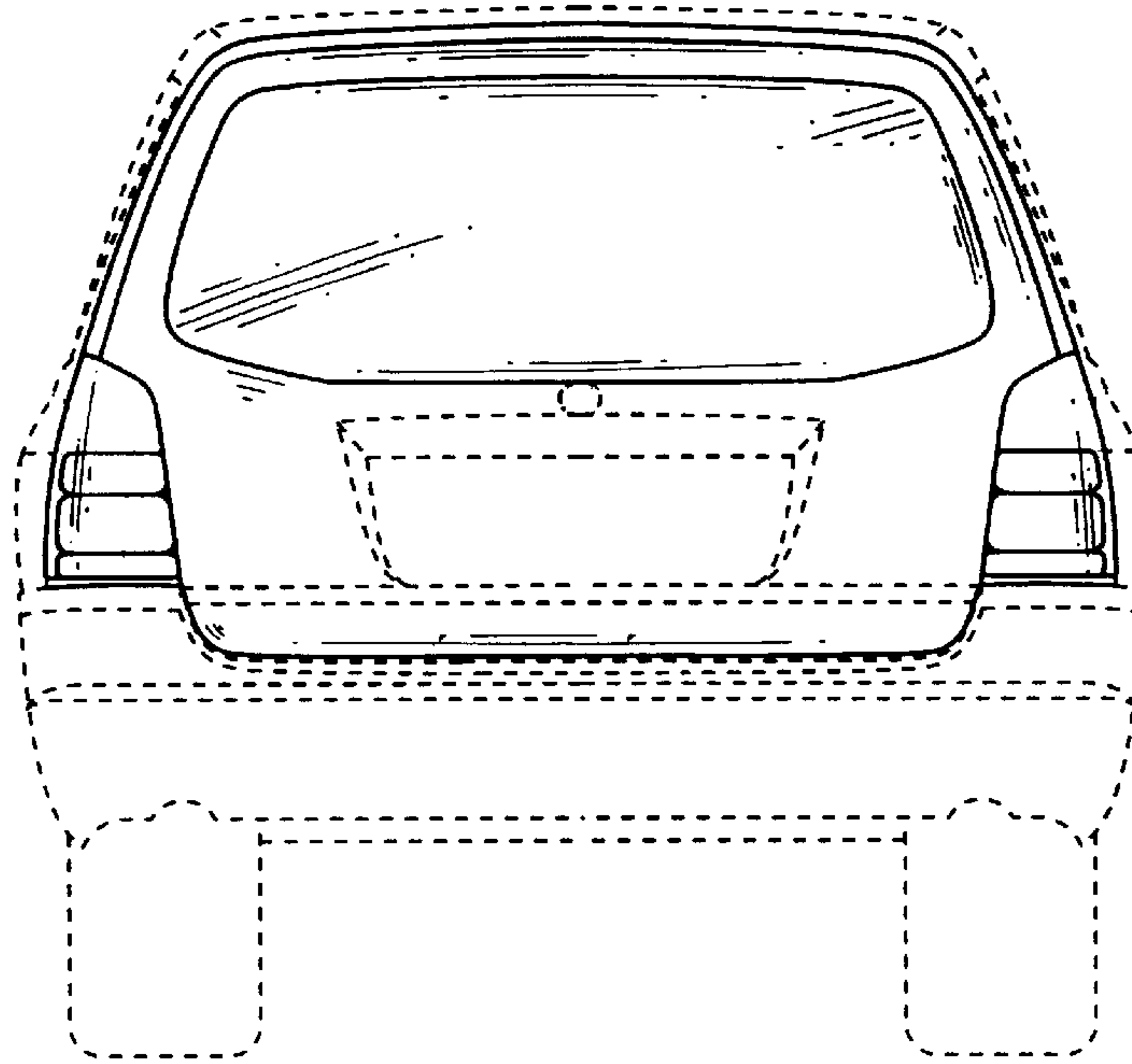

FIG. 3

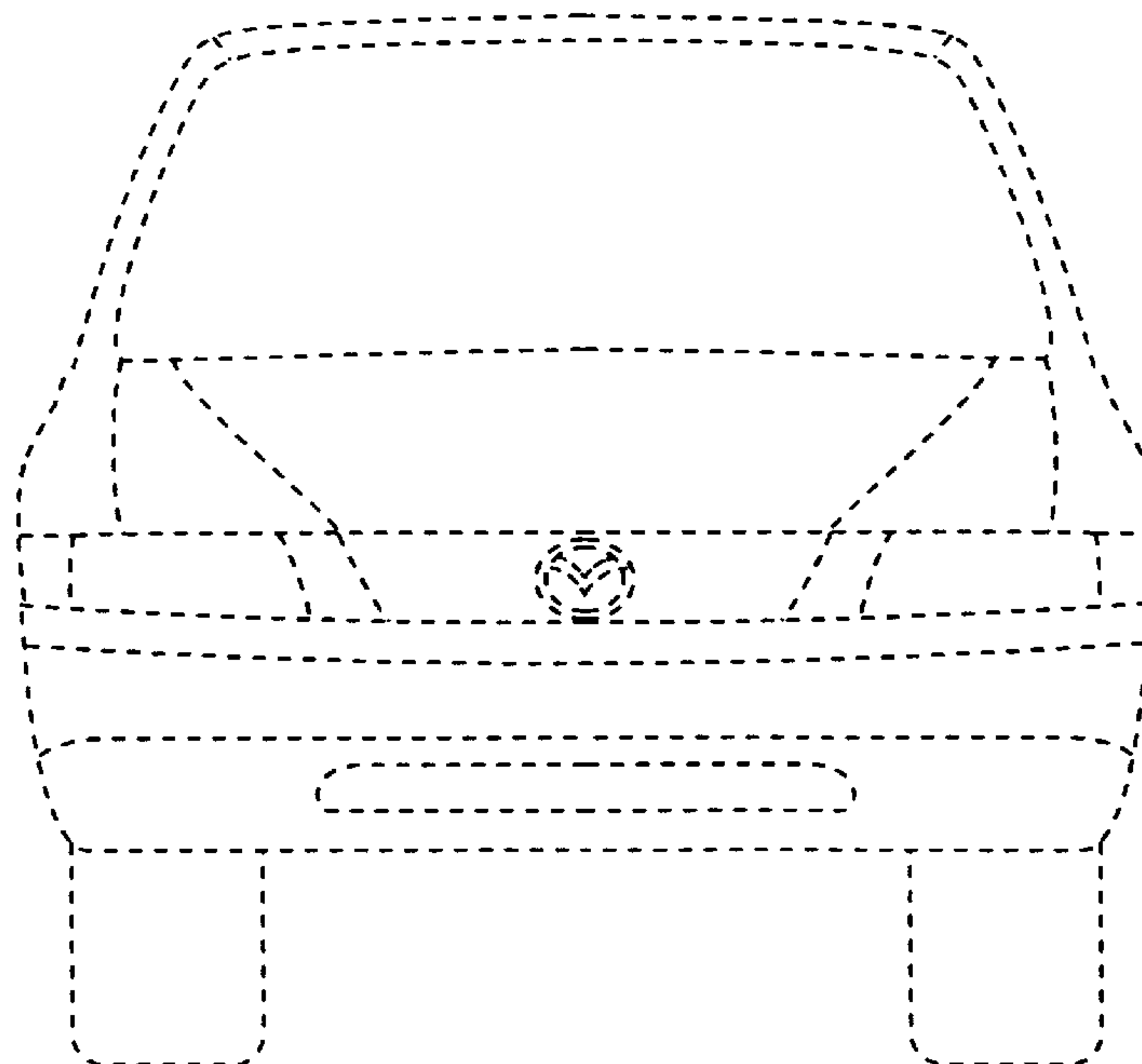

FIG. 4

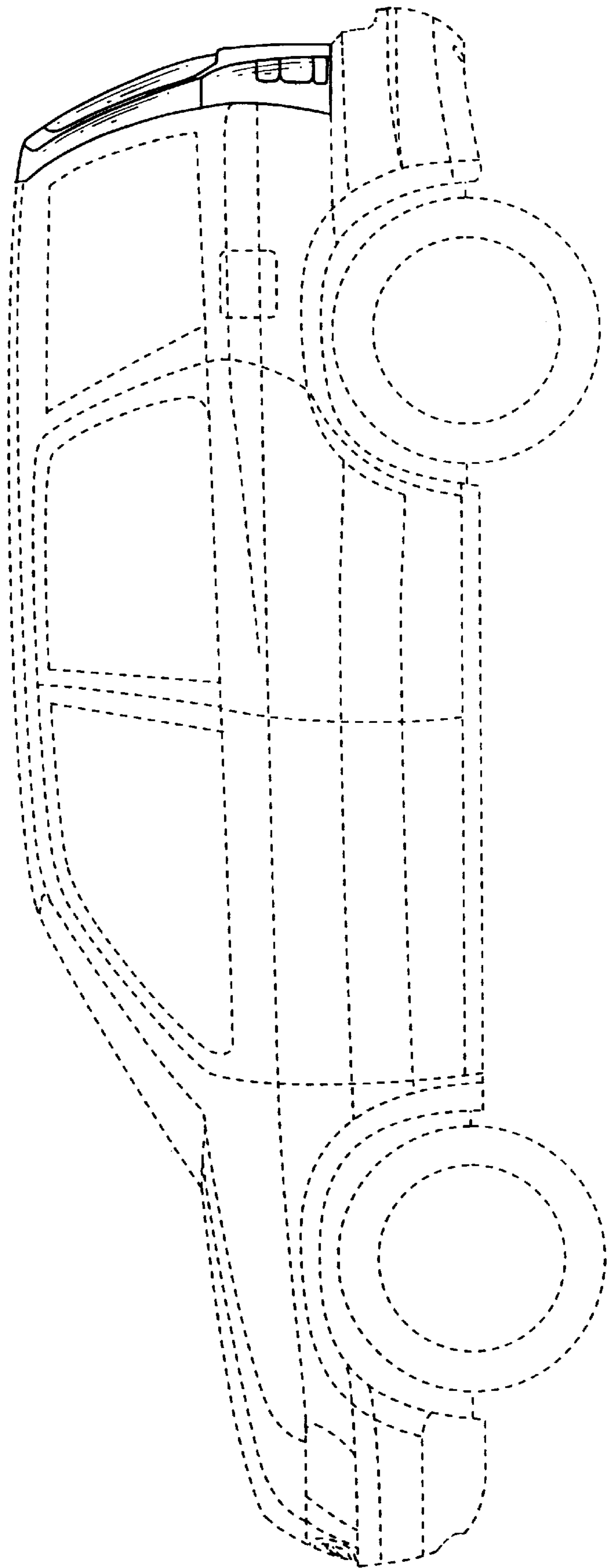

FIG. 5

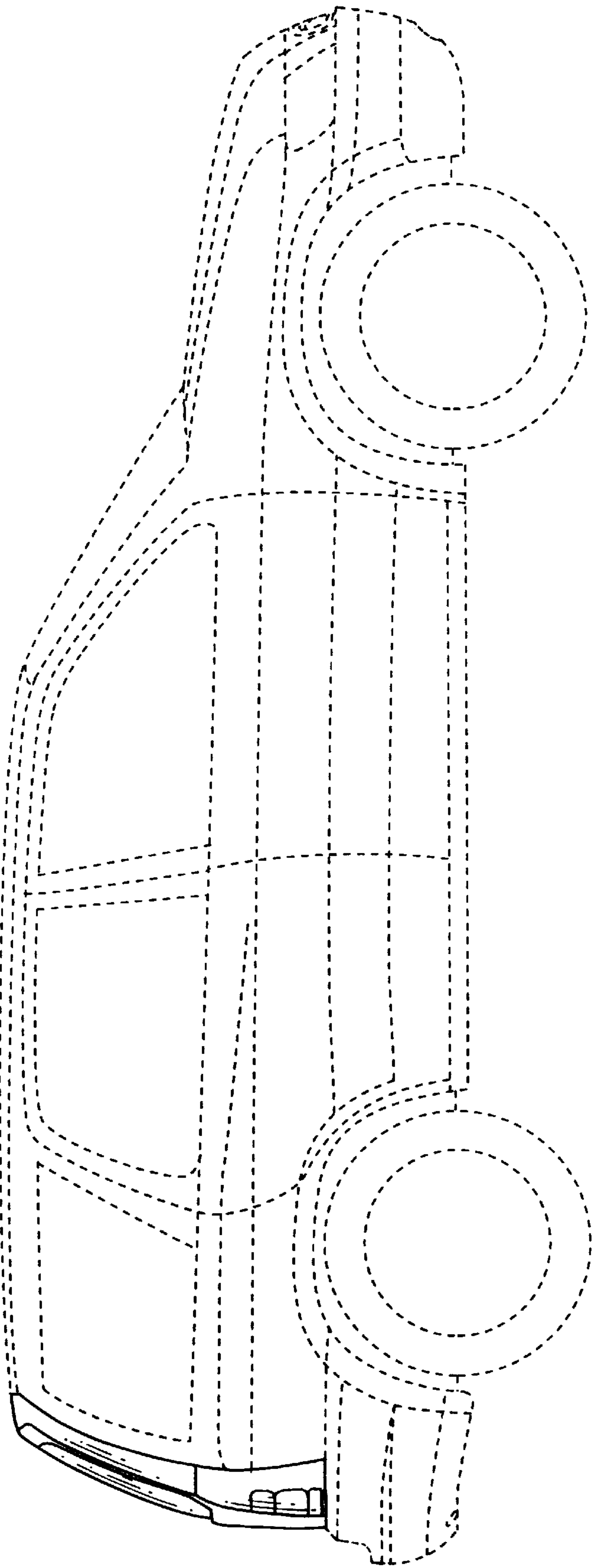



FIG. 6

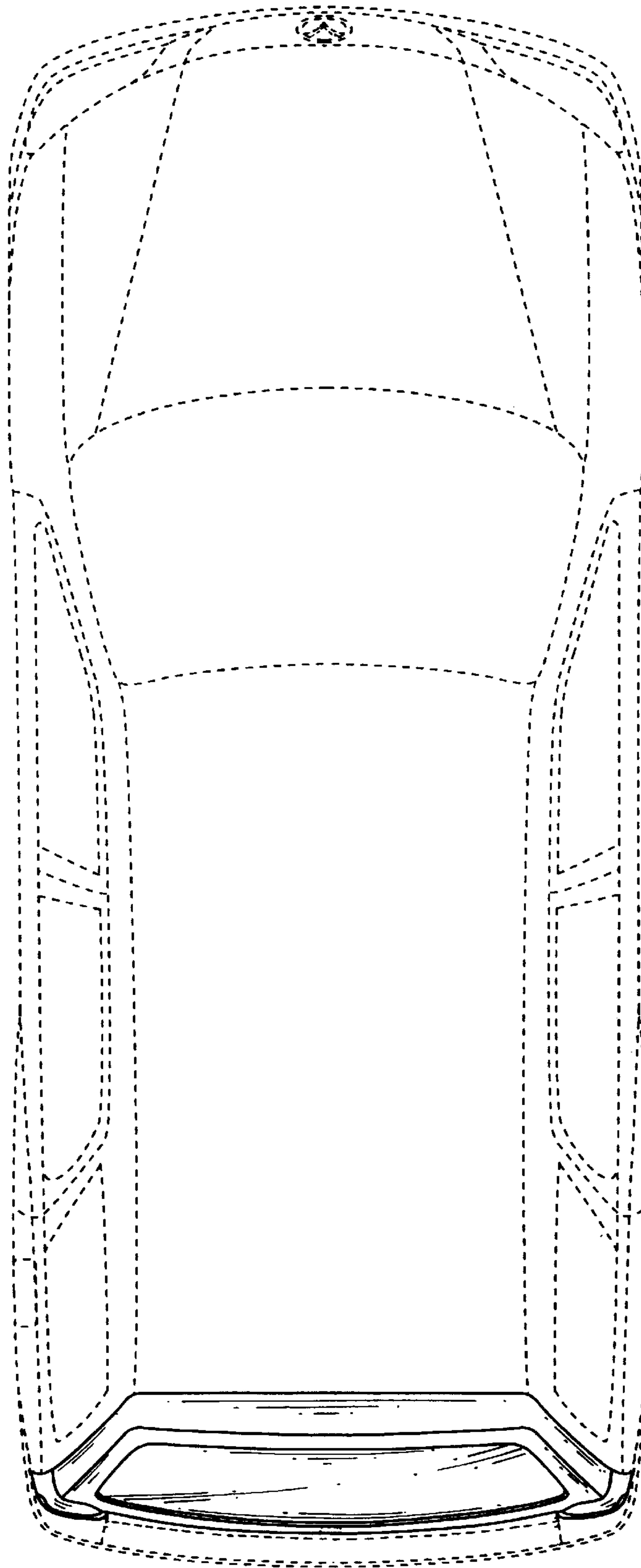

FIG. 7

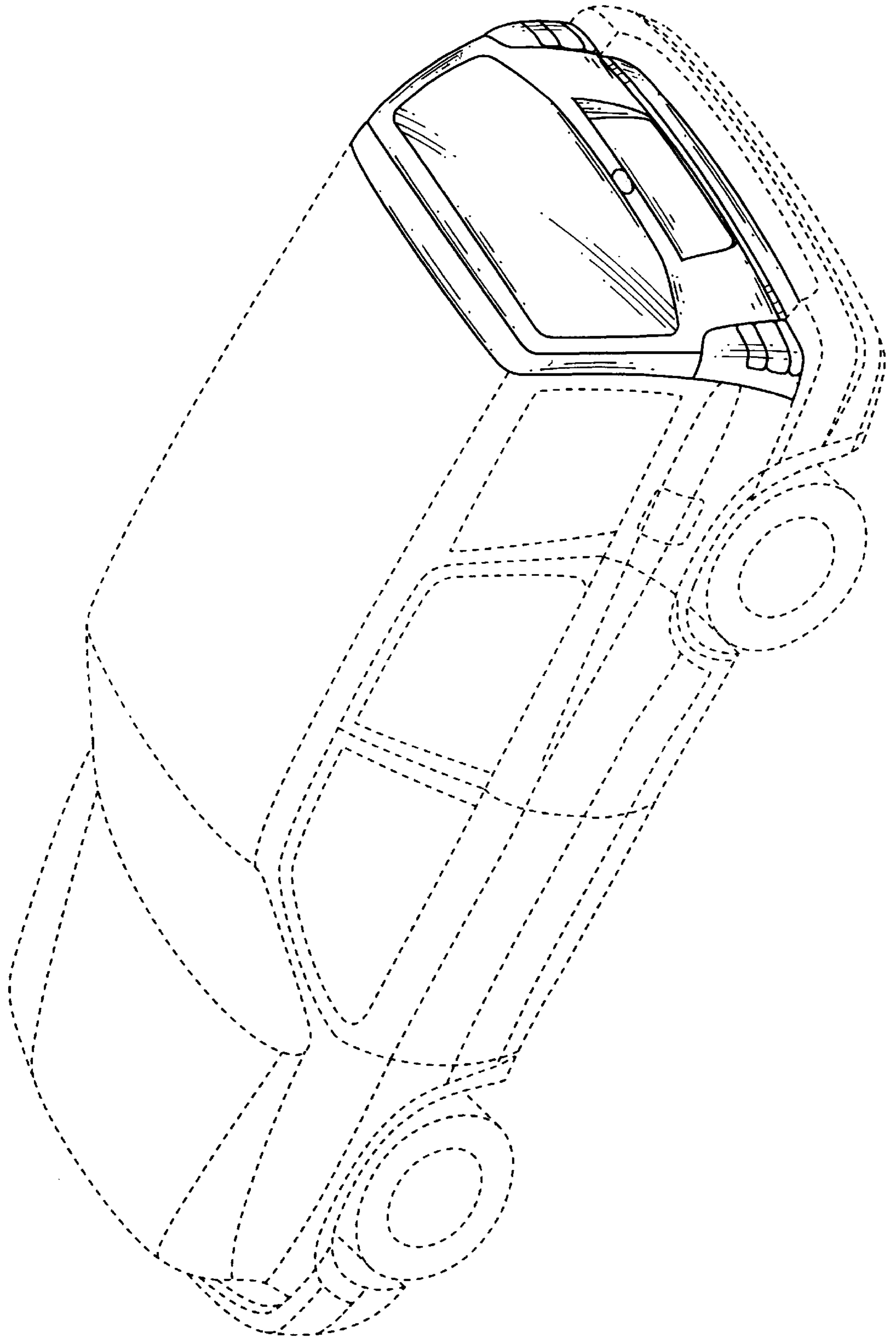

FIG. 8

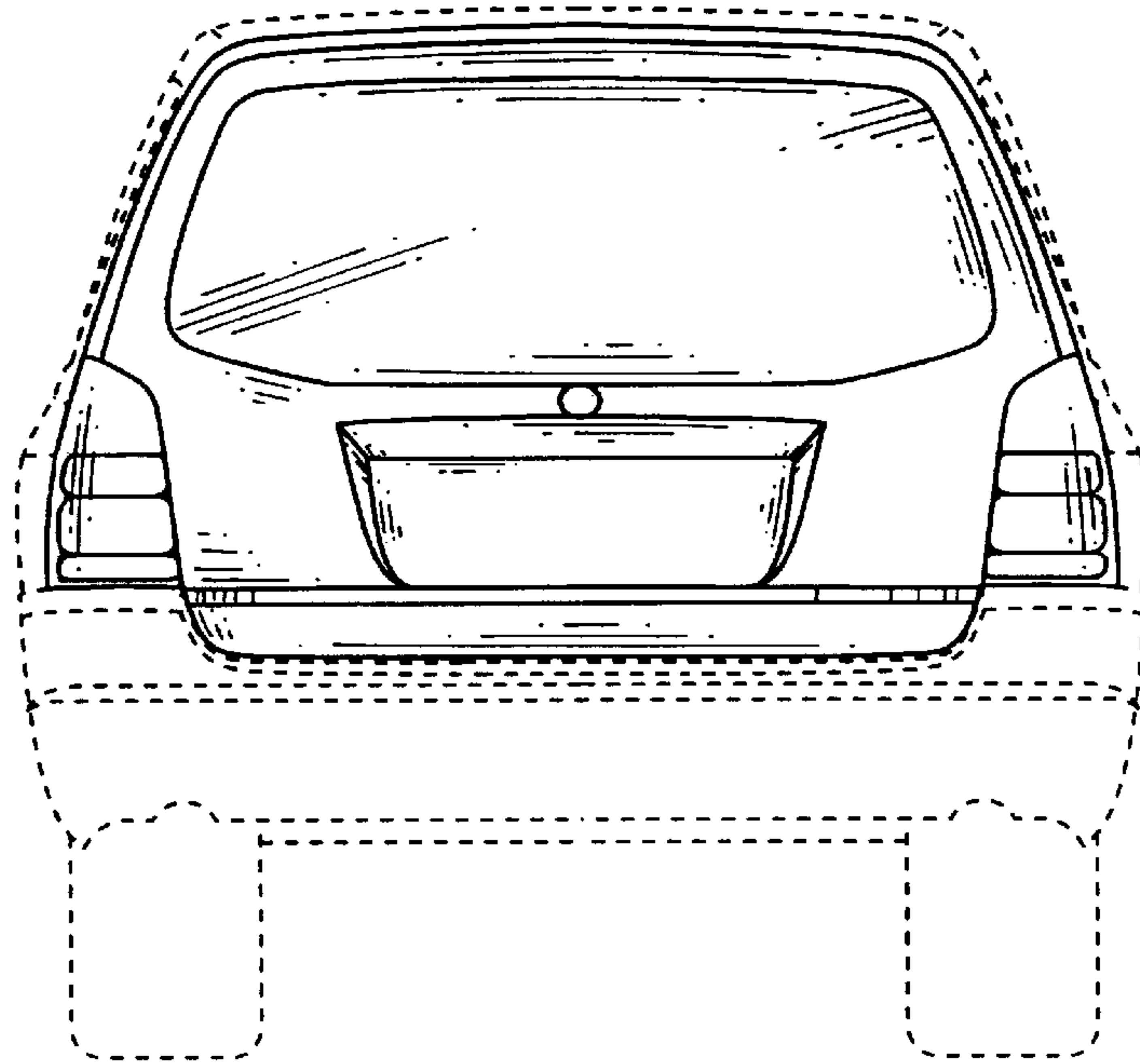

FIG. 9

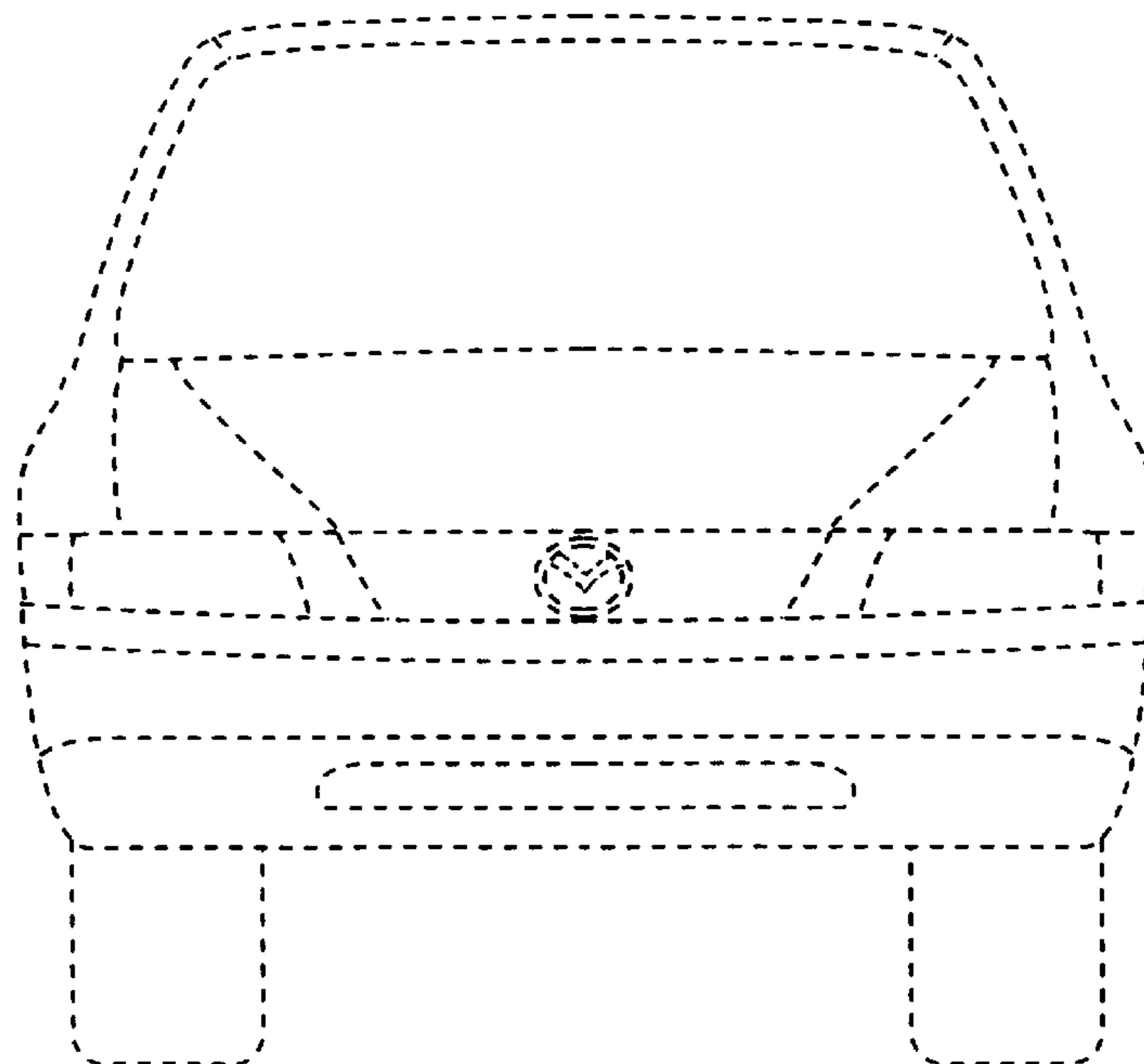



FIG. 10

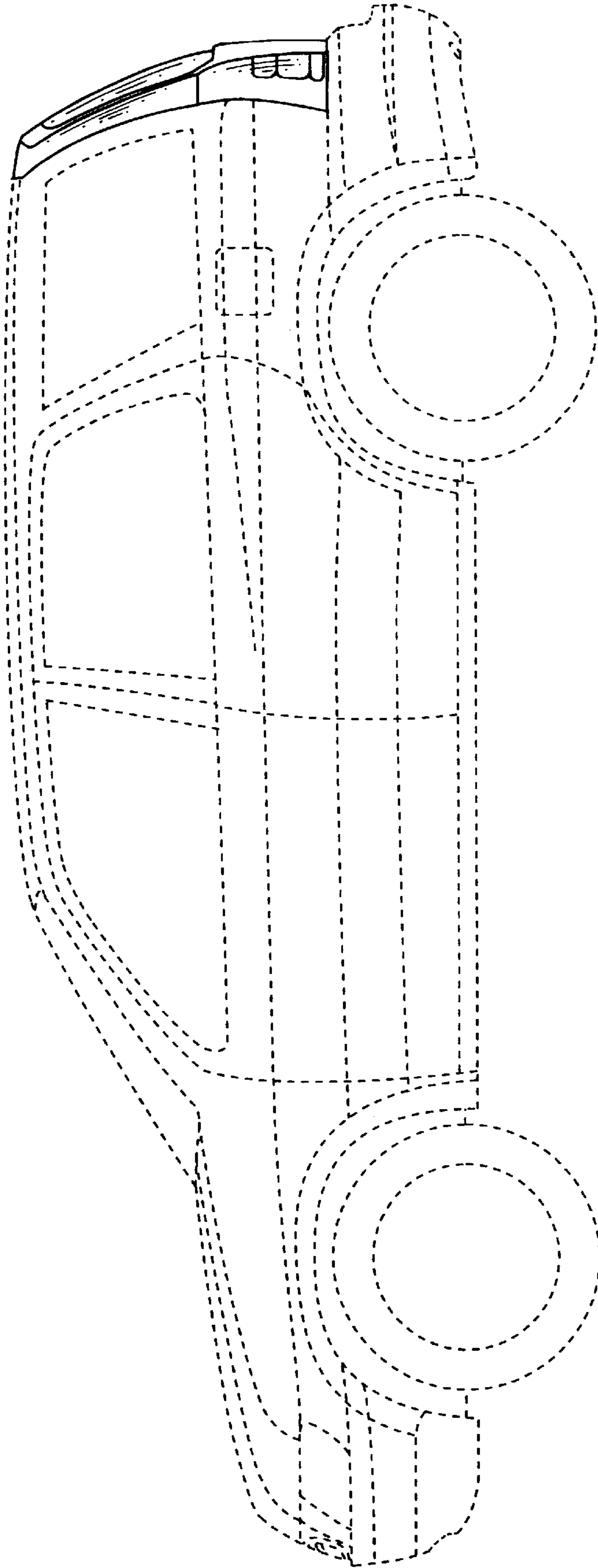

FIG. 11

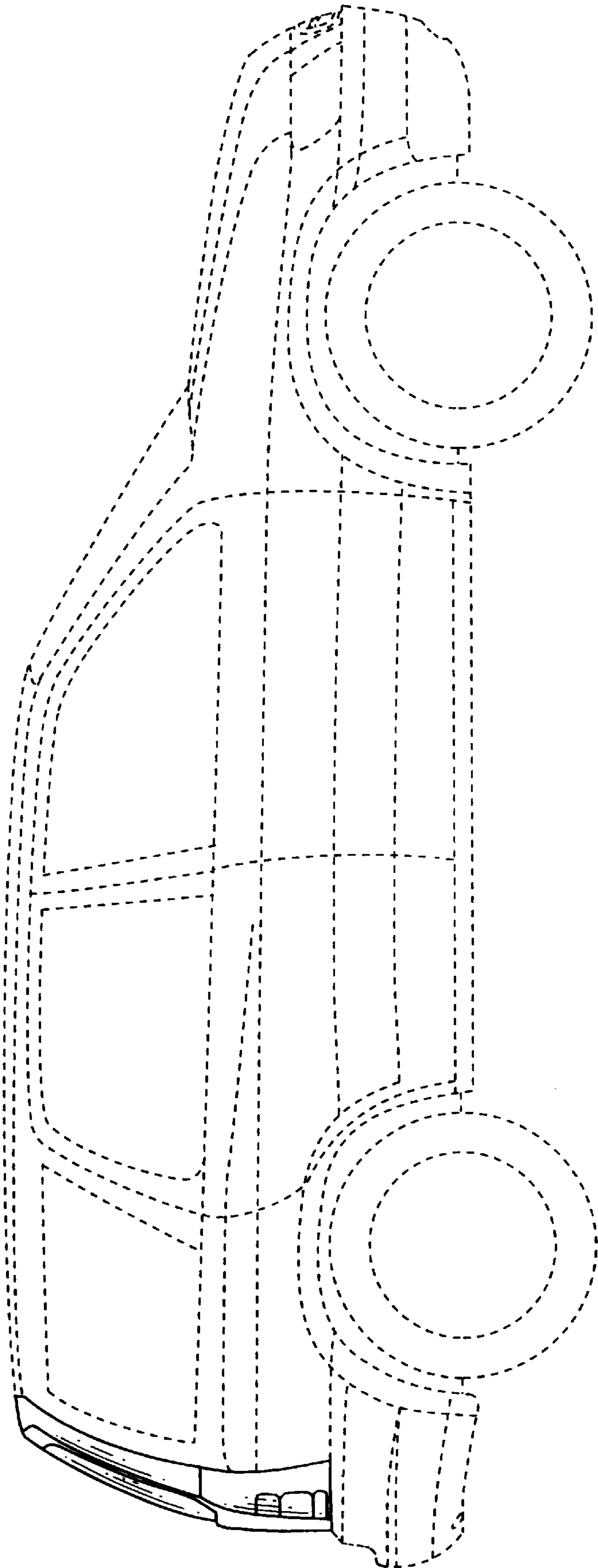

FIG. 12

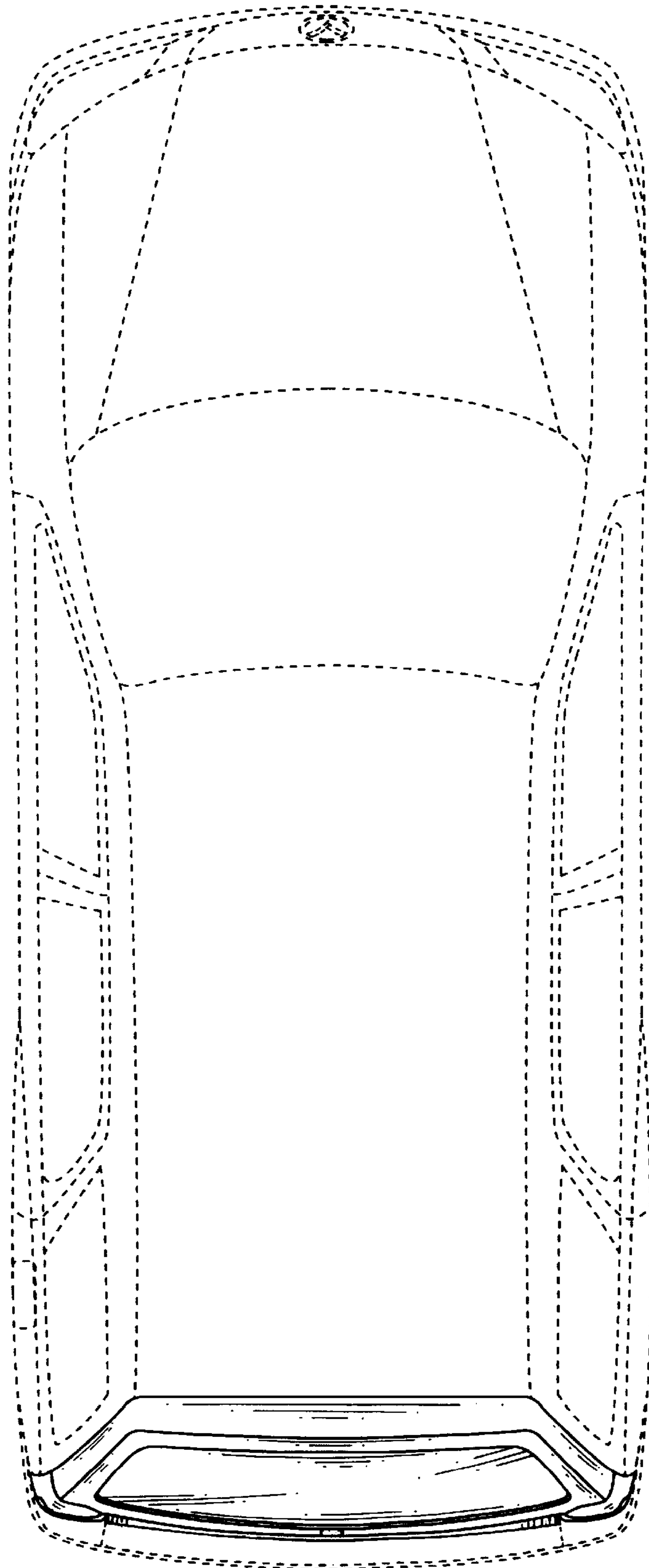

FIG. 13

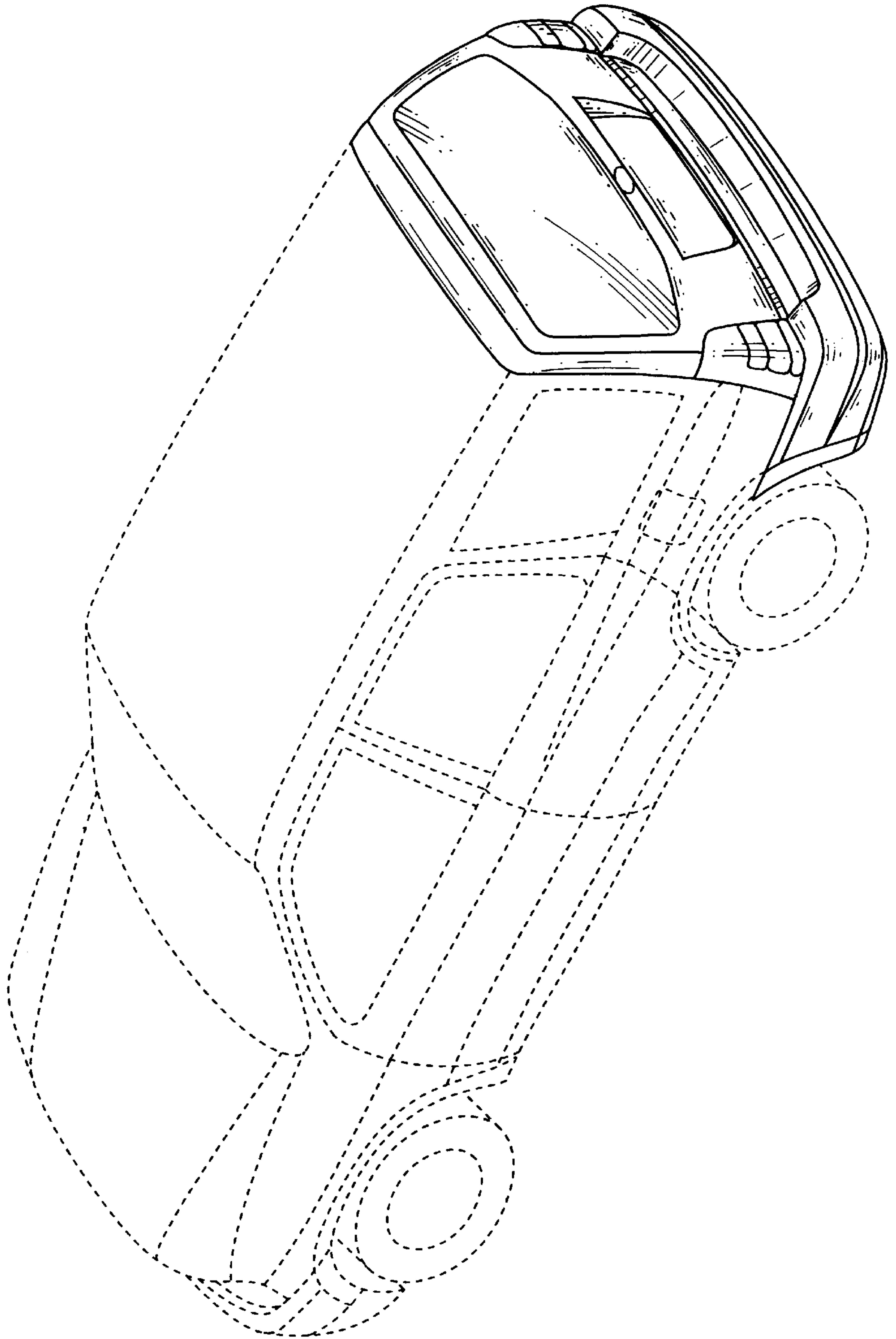

FIG. 14

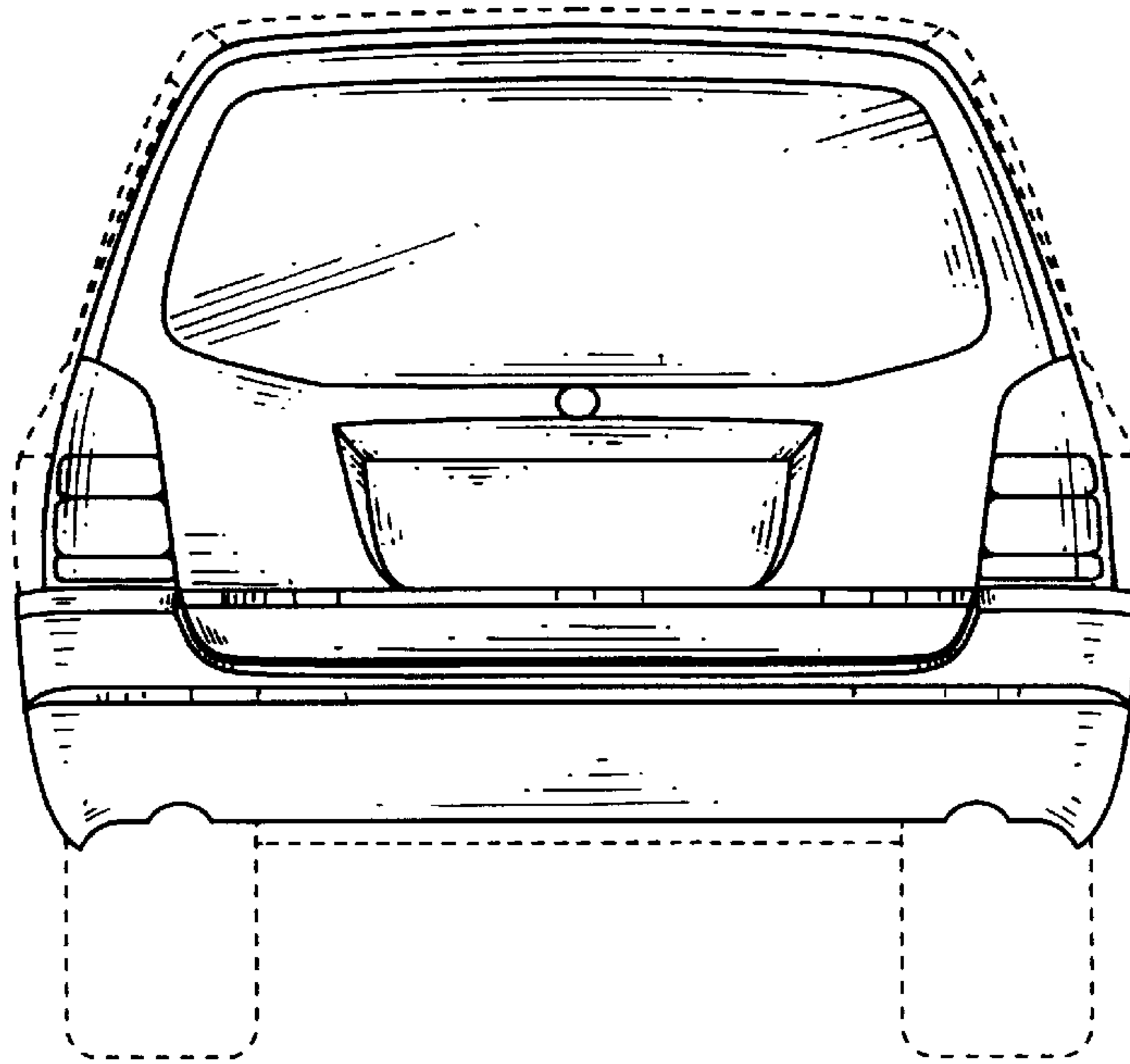
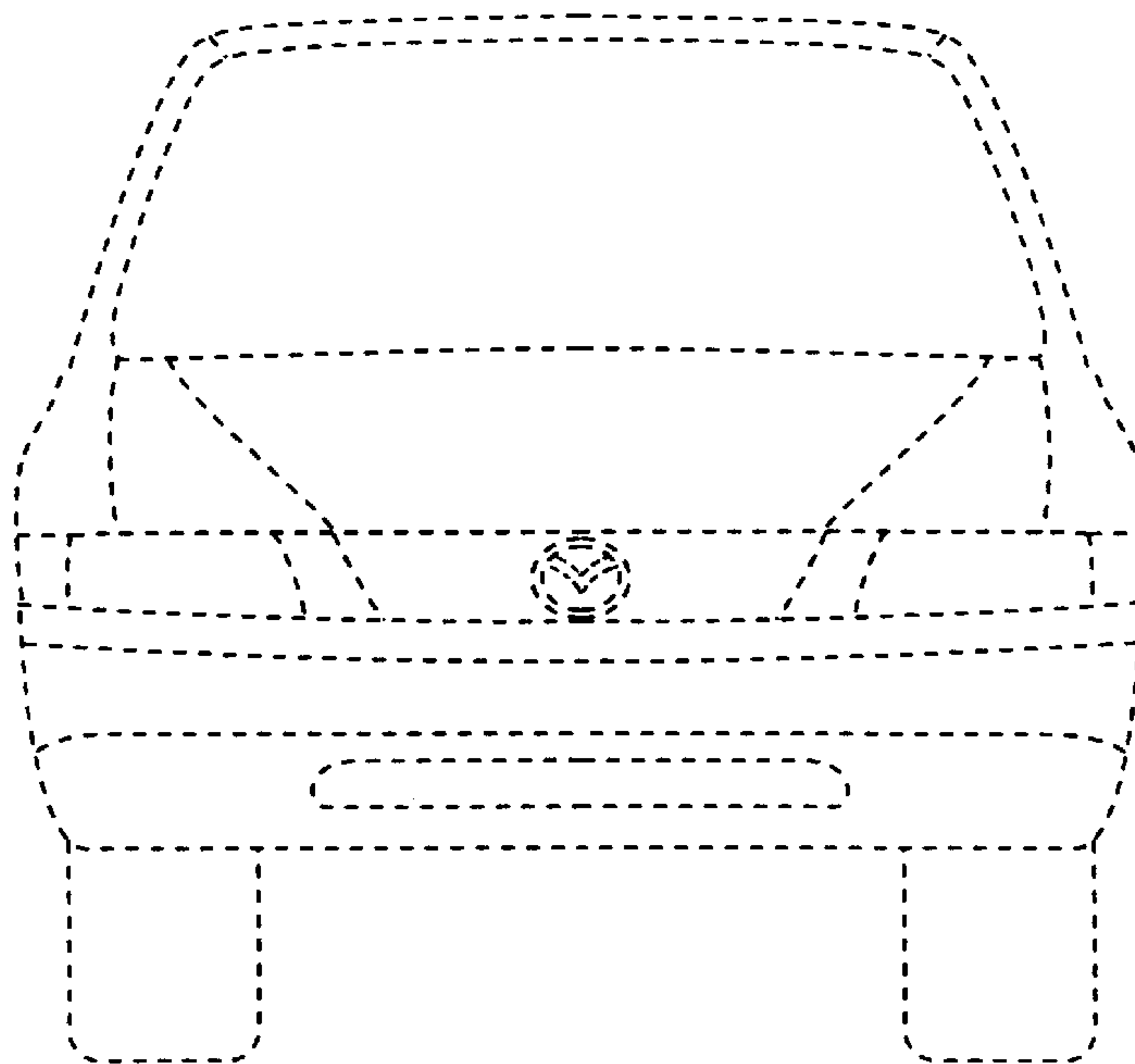

FIG. 15





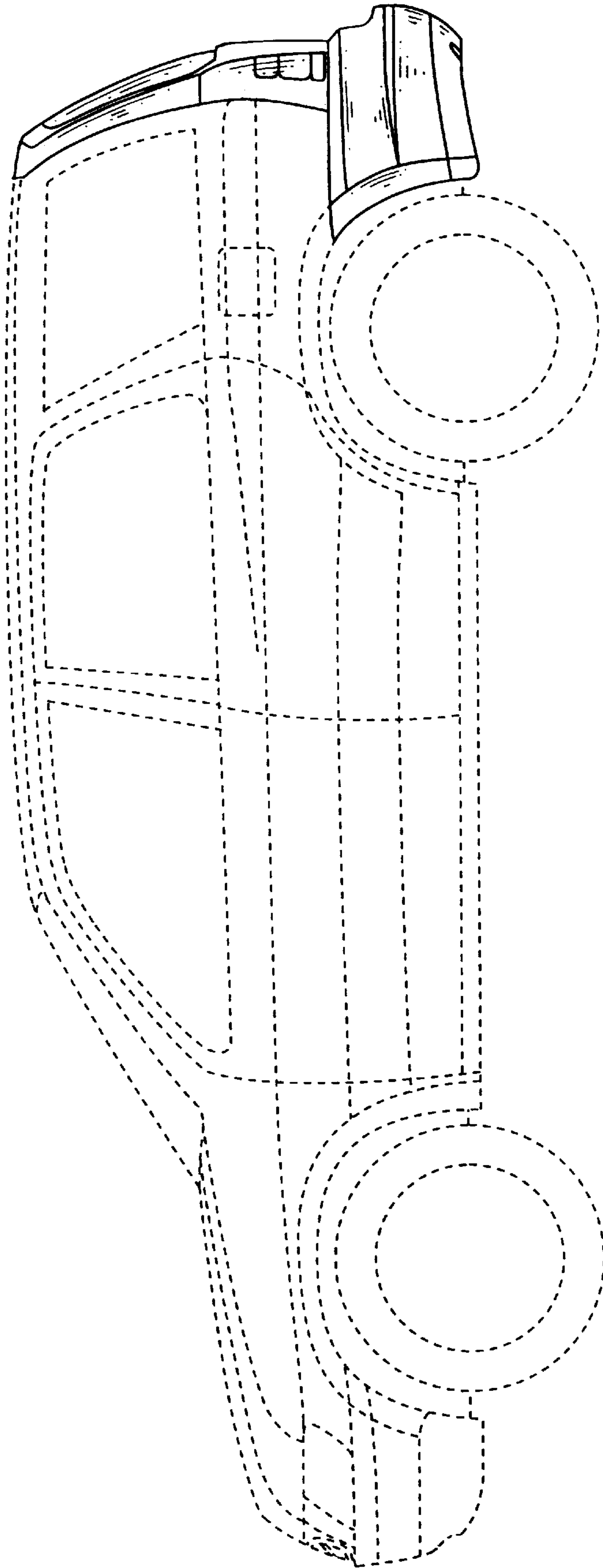

FIG. 16

FIG. 17

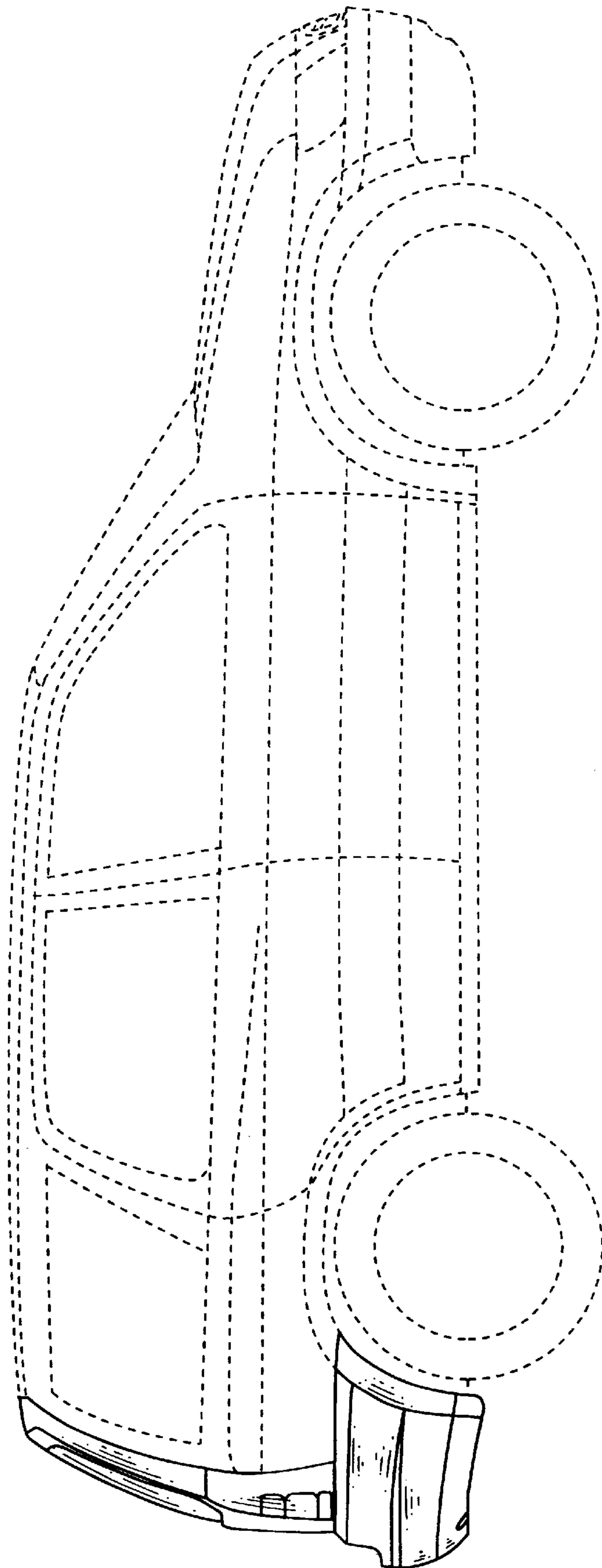

FIG. 18

