



US00D421946S

United States Patent [19] Drone

[11] Patent Number: Des. 421,946

[45] Date of Patent: ** Mar. 28, 2000

[54] ILLUMINATED CAR DASH COVER SET

D. 387,186 12/1997 Drone D2/501
D. 403,841 1/1999 Drone D2/894

[76] Inventor: Harry Drone, 3615 Blue Ridge Exit,
Apt. 2, Grandview, Mo. 64030

Primary Examiner—Robert M. Spear
Attorney, Agent, or Firm—Shook, Hardy & Bacon, LLP

[**] Term: 14 Years

[57] CLAIM

[21] Appl. No.: 29/089,604

The ornamental design for an illuminated car dash cover set,
as shown and described.

[22] Filed: Jun. 18, 1998

DESCRIPTION

[51] LOC (6) Cl. 12-16

[52] U.S. Cl. D12/190

[58] Field of Search D12/190, 192,
D12/195, 221; D2/627, 501, 894; D6/356,
511, 601, 611; D26/25, 38; 280/751, 752,
847

FIG. 1 is a perspective view of an illuminated car dash cover set according to the present invention;
FIG. 2 is a top plan view thereof;
FIG. 3 is a side elevation view thereof, the opposite side elevation view being substantially a mirror image thereof;
FIG. 4 is a front elevation view thereof; and,
FIG. 5 is a rear elevation view thereof.

[56] References Cited

U.S. PATENT DOCUMENTS

D. 162,228	2/1951	Russell	D12/192
D. 287,355	12/1986	Cornwell	D12/192
D. 291,983	9/1987	Cornwell	D12/192
D. 329,394	9/1992	Parsons et al.	D10/111
D. 335,763	5/1993	Jacob	D2/627

The broken line showing of an automobile interior is for illustrative purposes only and forms no part of the claimed design. The surface(s) or portion(s) of the article not shown in the drawing or described in the specification form(s) no part of the claimed design.

1 Claim, 3 Drawing Sheets

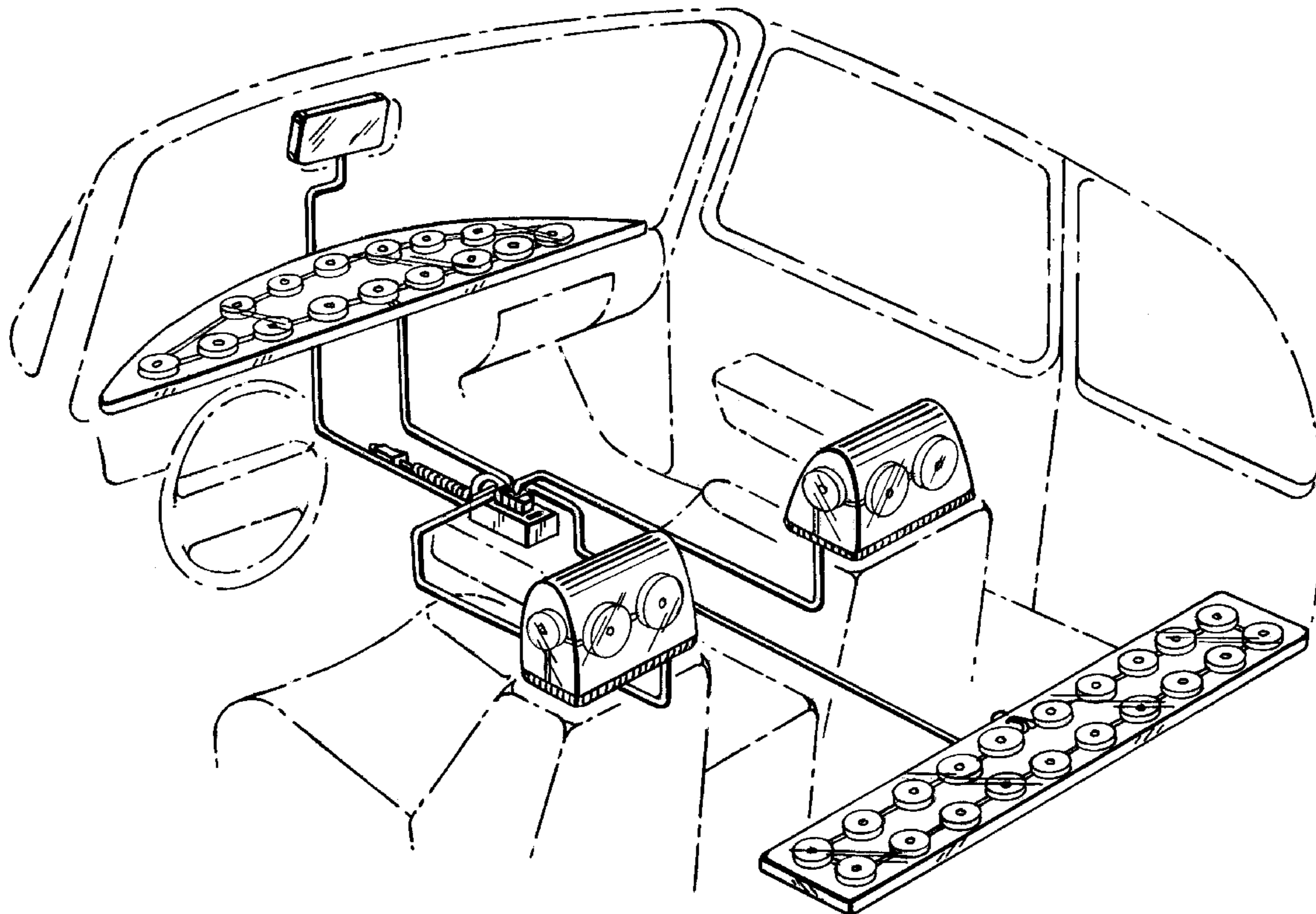

Fig. 1.

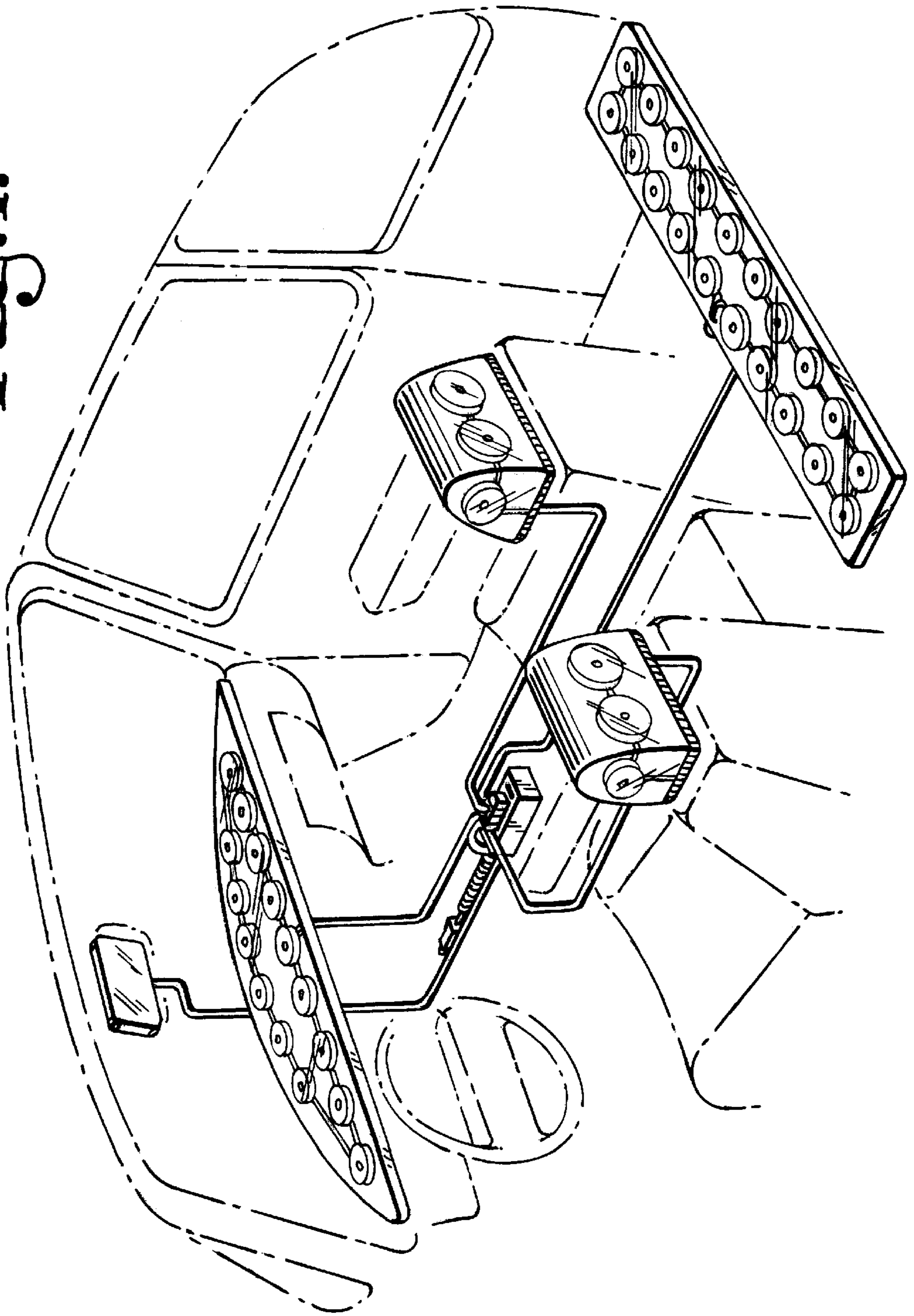

Fig. 2.

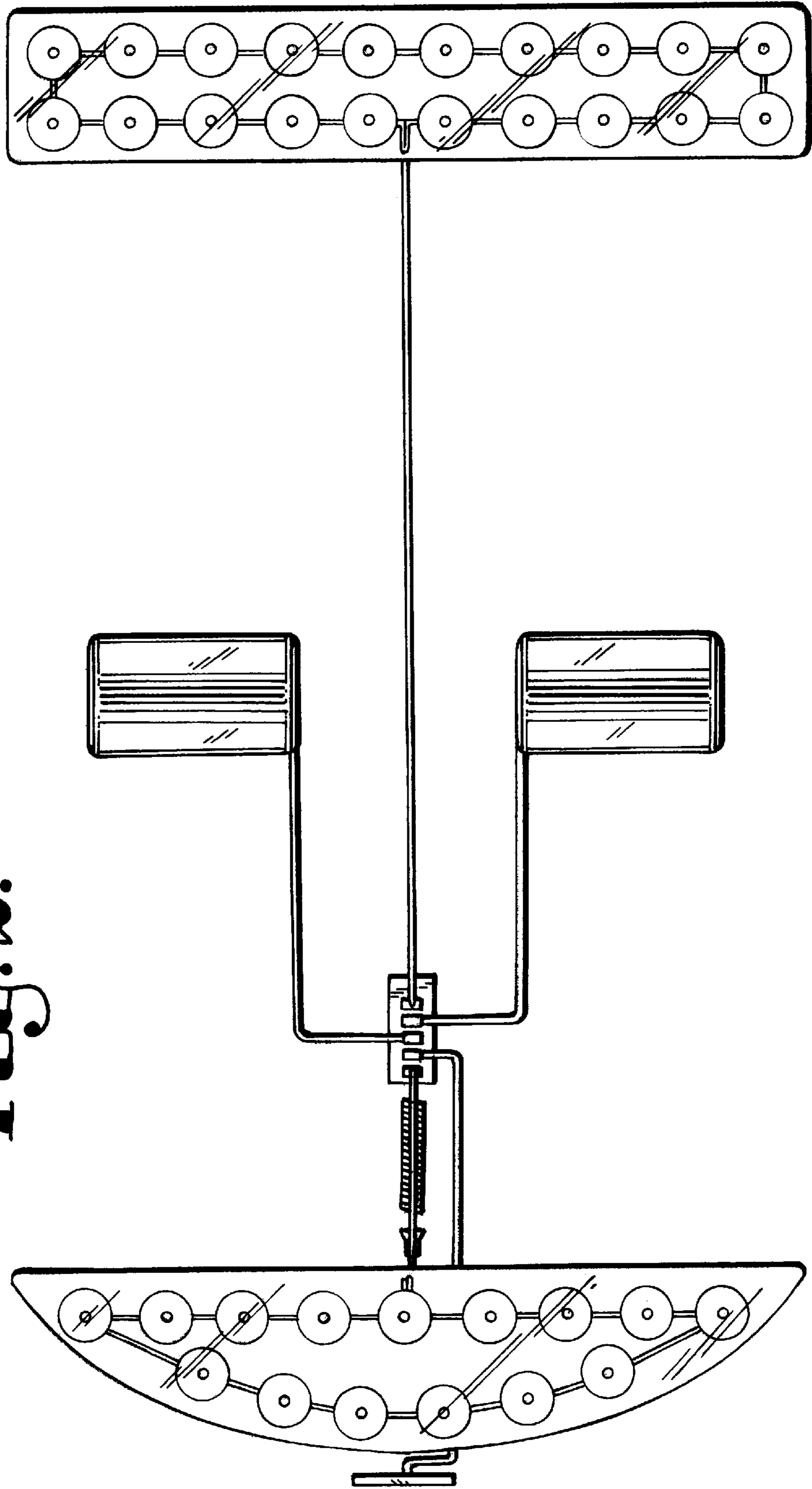

Fig. 3.

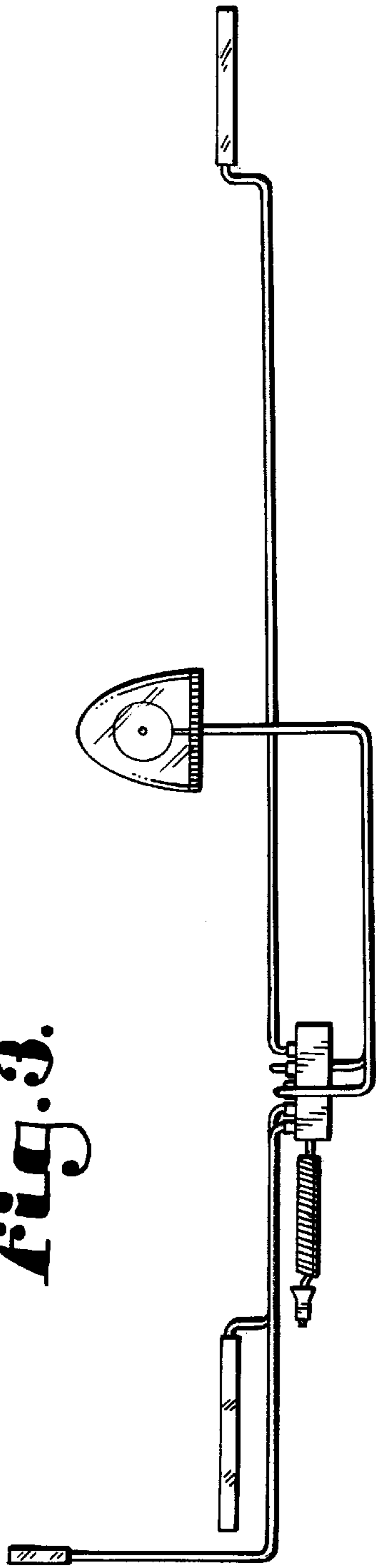

Fig. 4.

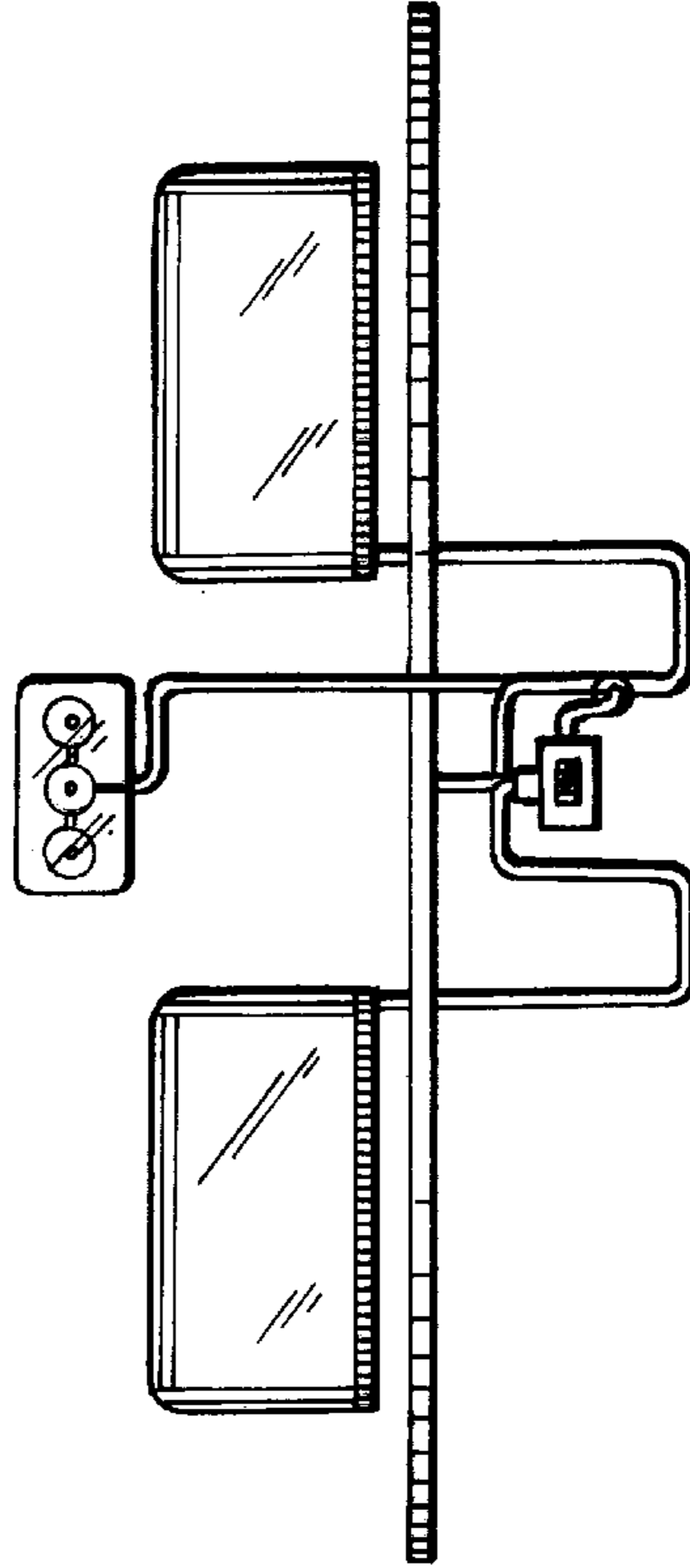

Fig. 5.

