



US00D421860S

United States Patent [19]

Gibson et al.

[11] Patent Number: Des. 421,860

[45] Date of Patent: ** Mar. 28, 2000

[54] INFANT CAR SEAT HANDLE

[75] Inventors: William R. Gibson, Kent; Paul K. Meeker, Hiram, both of Ohio

[73] Assignee: Evenflo Company, Inc., Vandalia, Ohio

[**] Term: 14 Years

[21] Appl. No.: 29/095,116

[22] Filed: Oct. 16, 1998

[51] LOC (6) Cl. 06-06

[52] U.S. Cl. D6/500; D6/333

[58] Field of Search D6/333, 334, 335, D6/356, 390, 391, 491, 500, 501, 502; 5/94; 297/183.1, 183.3, 184.13, 229, 256.16, 256.17, 250.1

5,104,134	4/1992	Cone .	
5,133,567	7/1992	Owens .	
5,143,419	9/1992	Tepper et al.	297/183.3
5,276,941	1/1994	Chen .	
5,277,472	1/1994	Freese et al. .	
5,324,094	6/1994	Kain .	
5,385,387	1/1995	Kain .	
5,409,292	4/1995	Kain et al. .	
5,454,584	10/1995	Haut et al. .	
5,490,685	2/1996	Kitayama et al. .	
5,516,190	5/1996	Kain et al. .	
5,522,639	6/1996	Jaime	297/183.3
5,540,365	7/1996	Lamair	297/250.1
5,605,409	2/1997	Haut et al. .	
5,645,293	7/1997	Cheng .	
5,651,581	7/1997	Myers et al.	297/183.1
5,658,044	8/1997	Krevh	297/183.1
5,676,386	10/1997	Huang	297/256.16
5,727,798	3/1998	Walters et al. .	

[56] **References Cited**

U.S. PATENT DOCUMENTS

D. 282,731	2/1986	Kain .	
D. 289,465	4/1987	Wise .	
D. 294,310	2/1988	Wise et al. .	
D. 294,777	3/1988	Wise et al. .	
D. 311,822	11/1990	Meeker .	
D. 353,288	12/1994	Kain .	
D. 357,439	4/1995	Haut et al. .	
D. 362,832	10/1995	Haut et al. .	
D. 369,707	5/1996	Kain .	
D. 378,908	4/1997	Courtney et al. .	
D. 390,168	2/1998	Haut .	
D. 402,124	12/1998	Haut et al.	D6/333
D. 404,938	2/1999	Greger	D6/491
4,634,177	1/1987	Meeker .	
4,819,958	4/1989	Perego .	
4,943,113	7/1990	Meeker .	
5,092,004	3/1992	Cone et al. .	

Primary Examiner—Doris V. Coles
Assistant Examiner—Mimosa De
Attorney, Agent, or Firm—Thompson Hine & Flory LLP

[57] **CLAIM**

The ornamental design of the infant car seat handle, as shown and described.

DESCRIPTION

FIG. 1 is a perspective view of the infant car seat handle showing the design of our invention; FIG. 2 is a left side elevational view thereof; FIG. 3 is a right side elevational view thereof; FIG. 4 is a front elevational view thereof; FIG. 5 is a rear elevational view thereof; FIG. 6 is a top elevational view thereof; and, FIG. 7 is a bottom elevational view thereof.

1 Claim, 3 Drawing Sheets

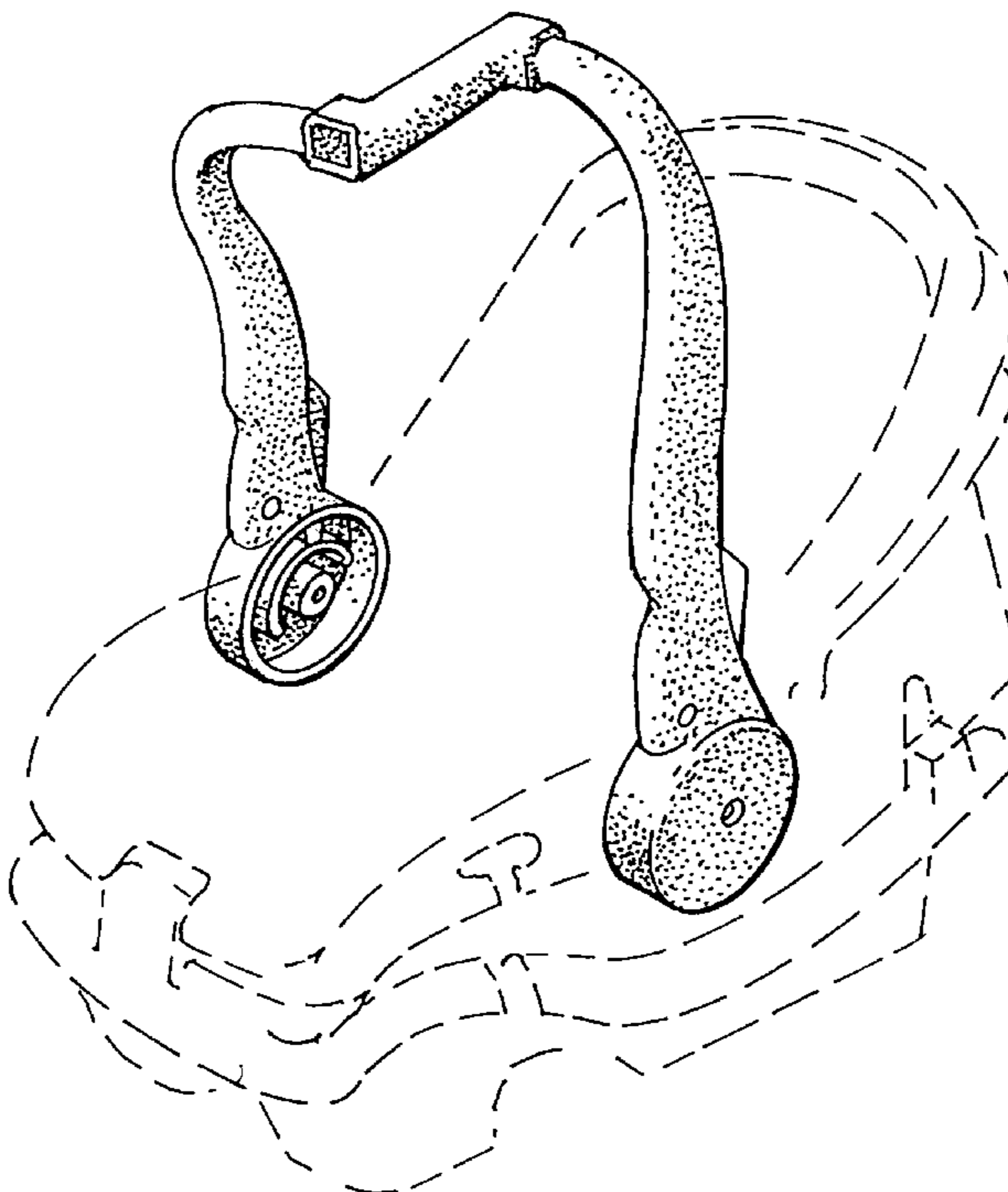

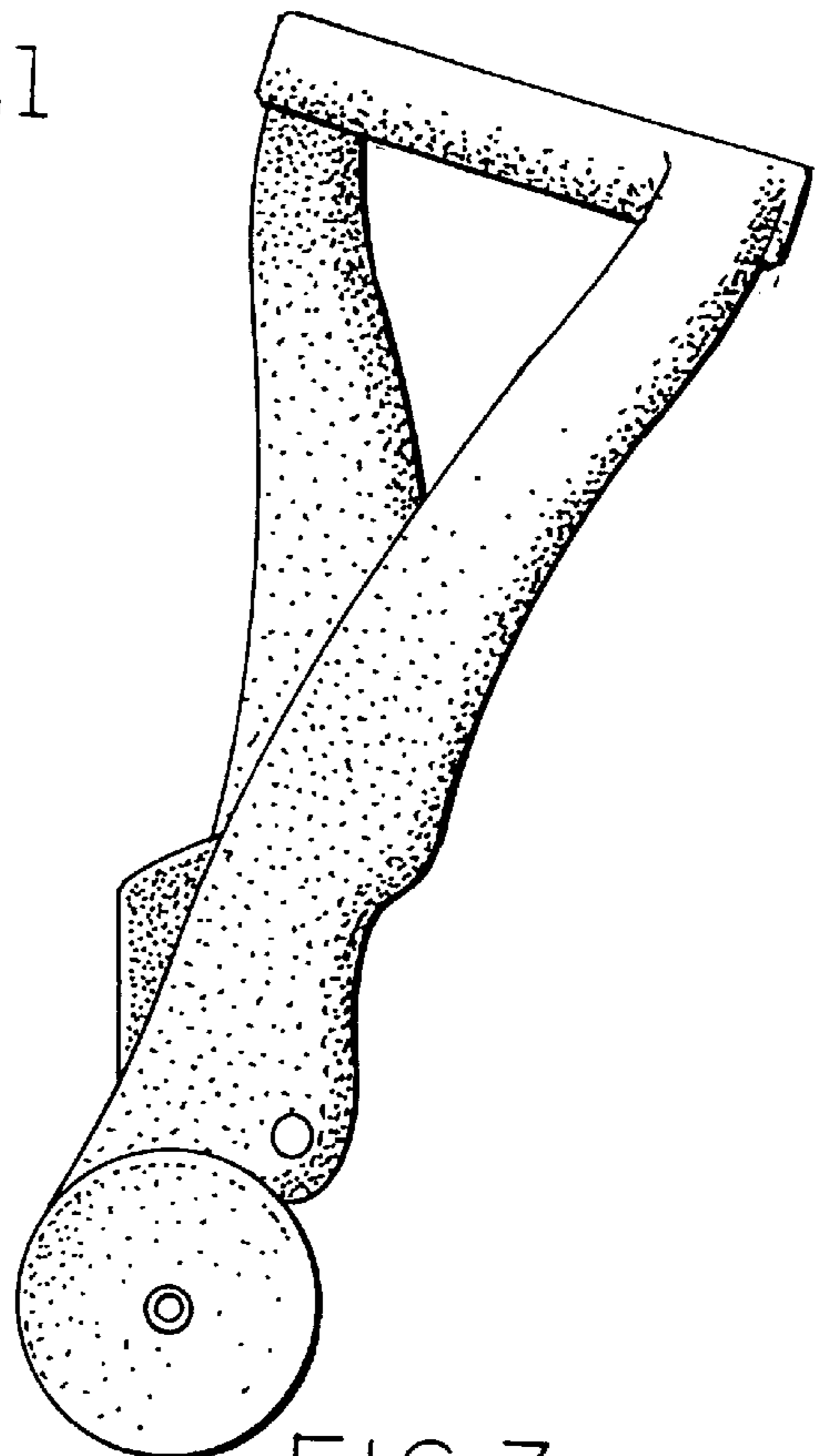
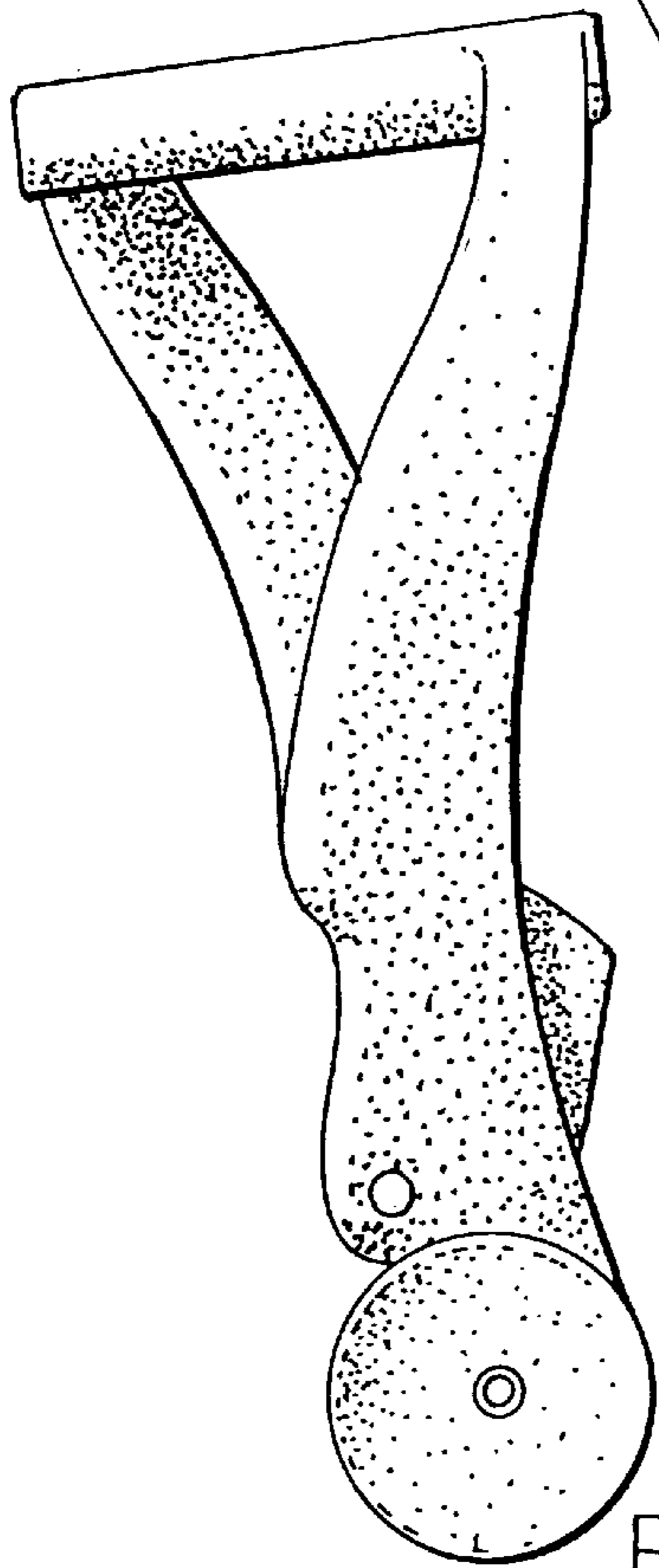
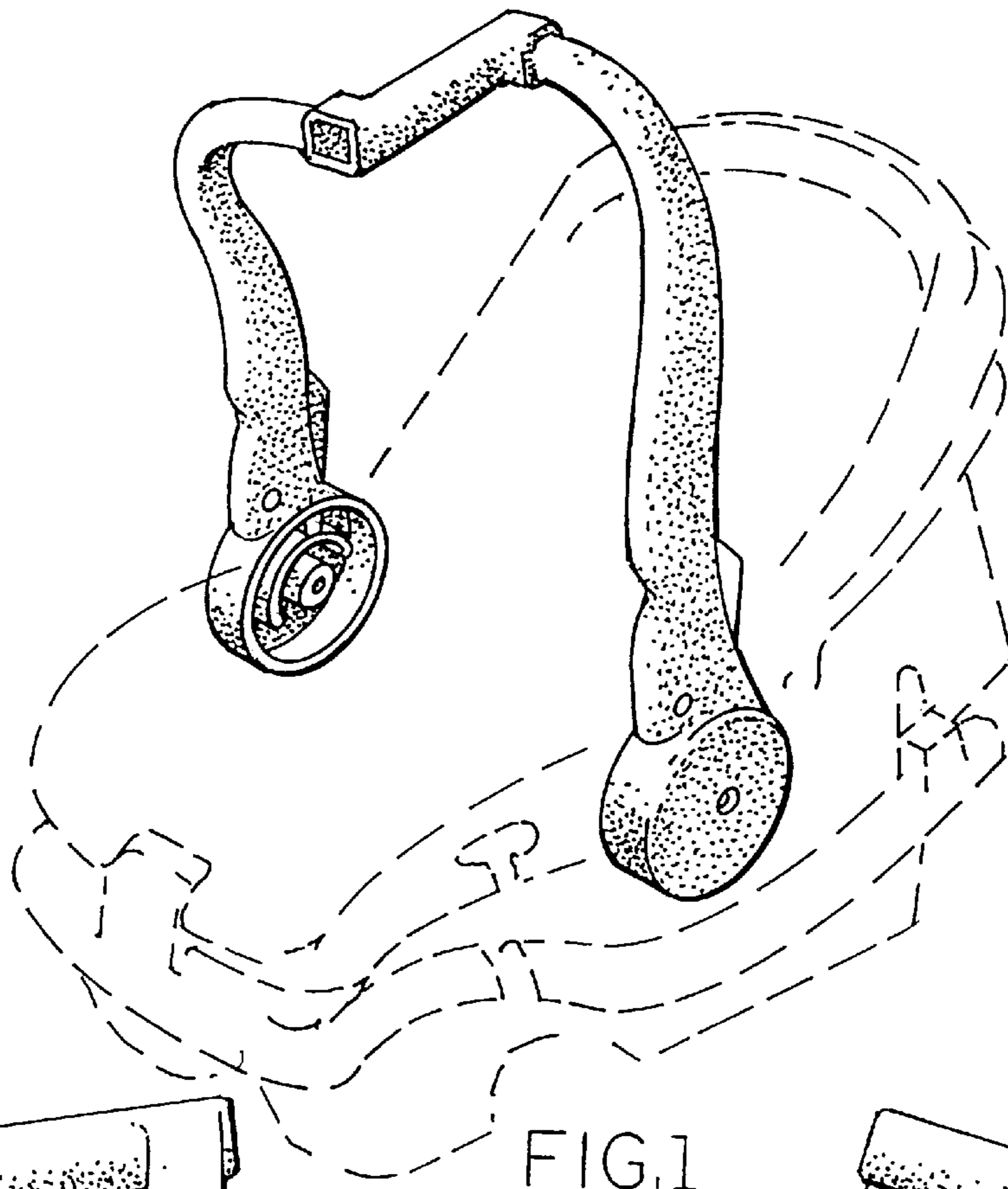

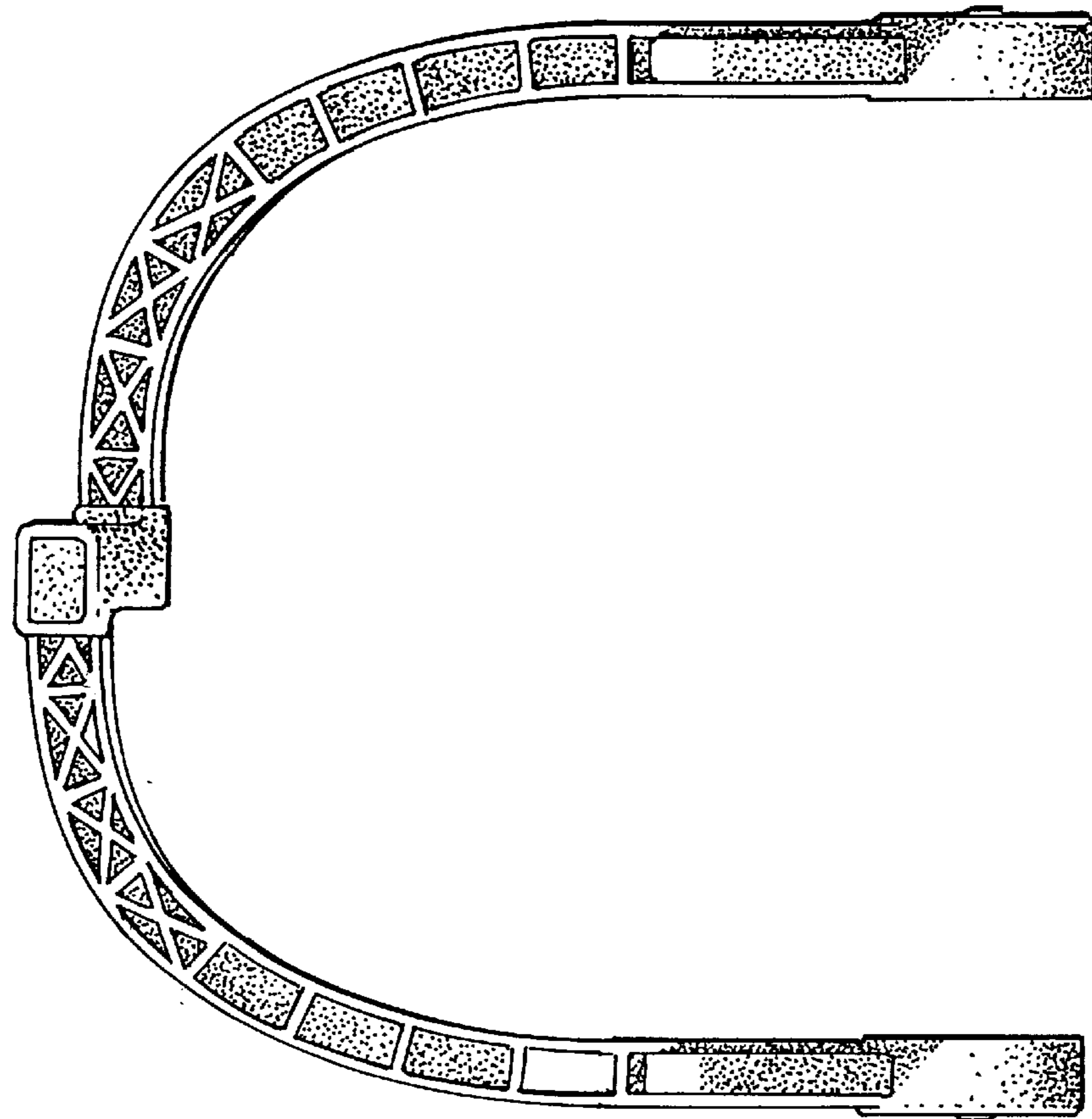

FIG. 5

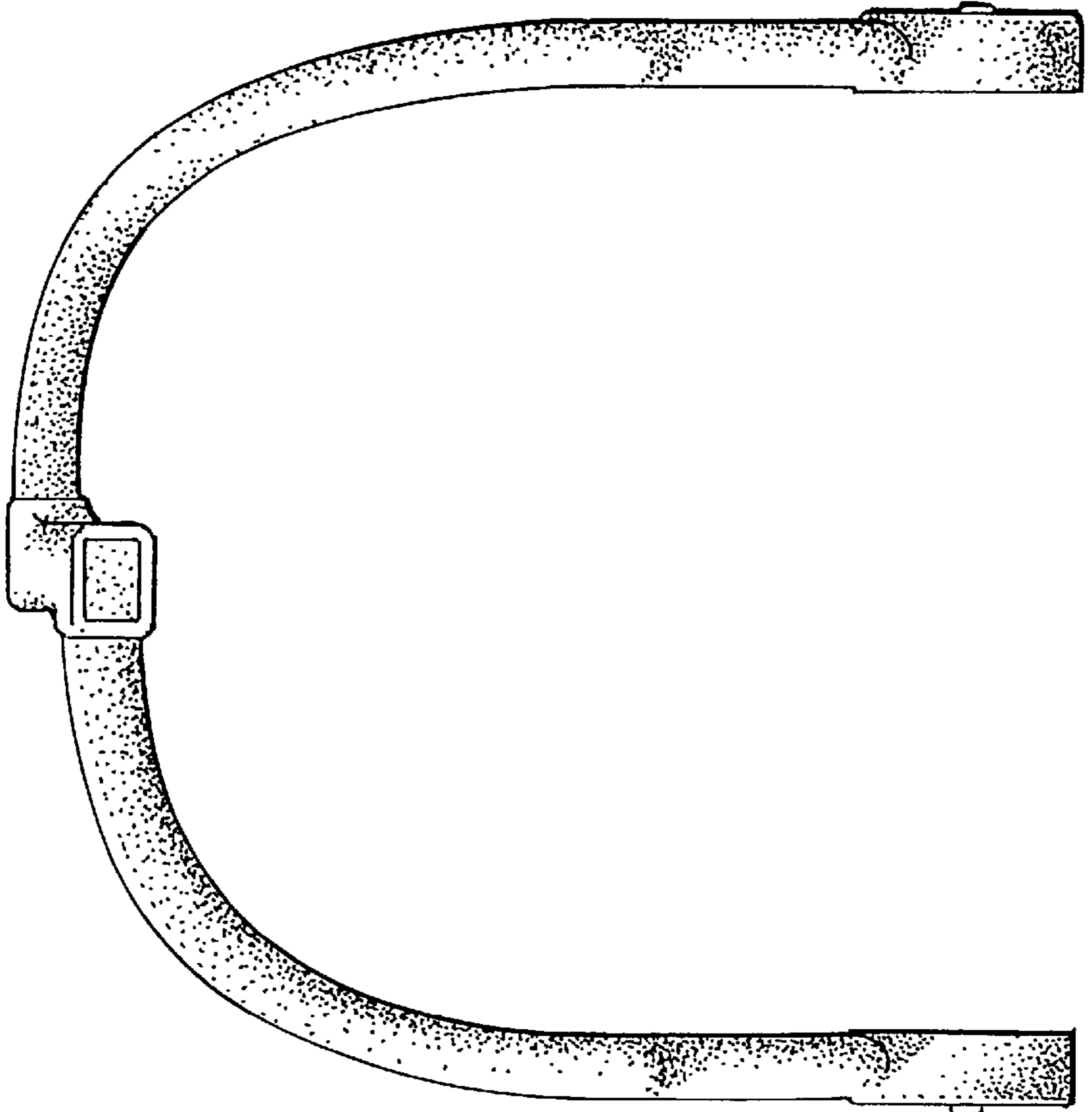

FIG. 4

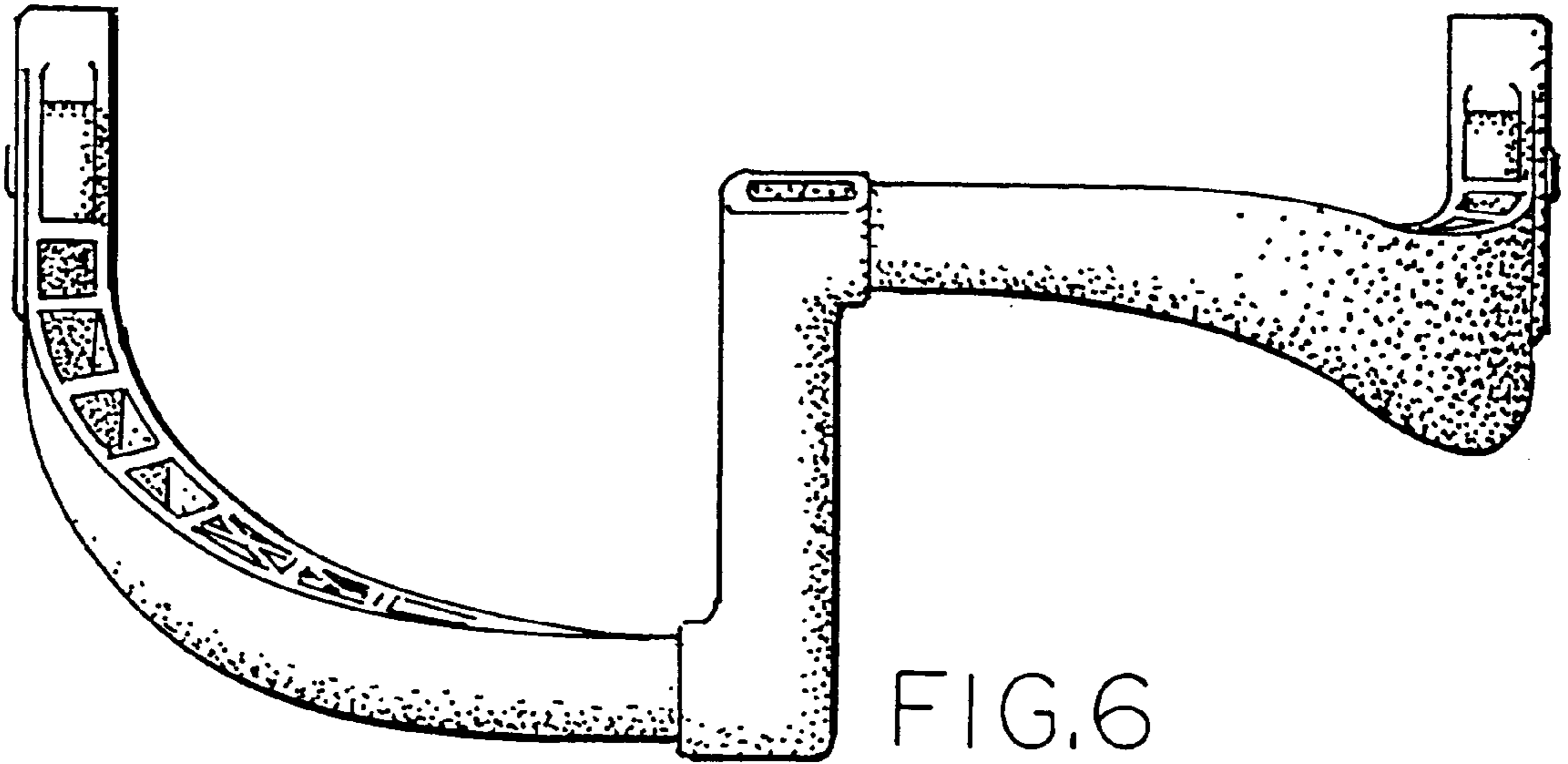

FIG. 6

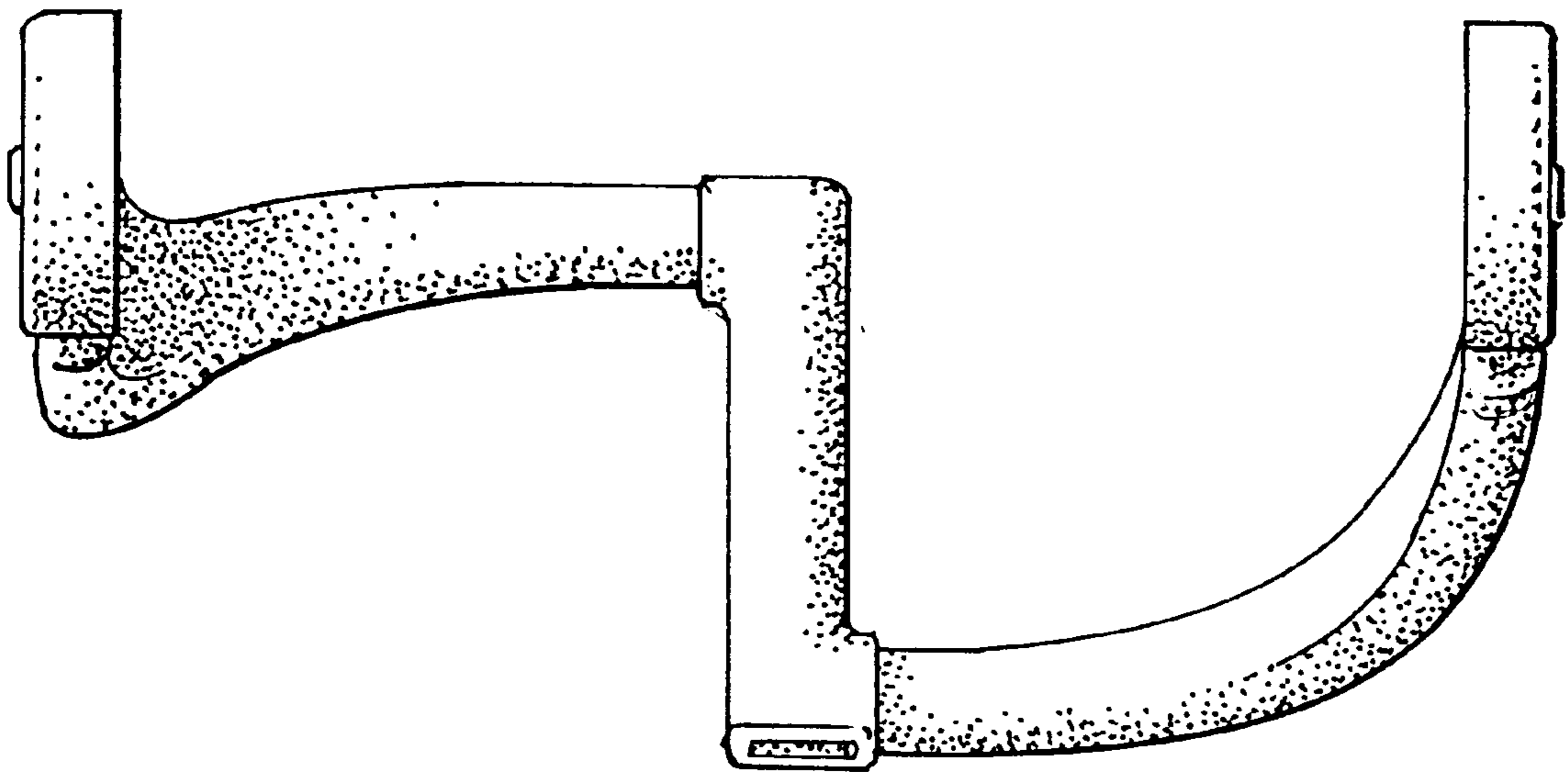

FIG. 7