



US00D421817S

United States Patent [19]

Tucker et al.

[11] Patent Number: **Des. 421,817**

[45] Date of Patent: **** Mar. 21, 2000**

[54] **HEADLAMP BEZEL FOR A MOTOR VEHICLE**

D. 387,471 12/1997 Alger D26/139
D. 403,803 1/1999 Alger D26/139
4,366,530 12/1982 Milhous 362/80

[75] Inventors: **Eric N. Tucker; John G. Myers**, both of Denton, Tex.

Primary Examiner—Marcus A. Jackson
Attorney, Agent, or Firm—Sidley & Austin

[73] Assignee: **Paccar Inc**, Bellevue, Wash.

[57] **CLAIM**

[**] Term: **14 Years**

The ornamental design for a headlamp bezel for a motor vehicle, as shown and described.

[21] Appl. No.: **29/105,926**

DESCRIPTION

[22] Filed: **Jun. 3, 1999**

FIG. 1 is a perspective view of our headlamp bezel for a motor vehicle;
FIG. 2 is a top view thereof;
FIG. 3 is a front view thereof;
FIG. 4 is a back view thereof;
FIG. 5 is a bottom view thereof;
FIG. 6 is a left side view thereof; and,
FIG. 7 is a right side view thereof.

[51] **LOC (6) Cl.** **26-99**

[52] **U.S. Cl.** **D26/139**

[58] **Field of Search** D26/38-36, 139;
D12/114; 362/61, 70, 71, 72, 80, 82, 83,
329-340, 354, 359

The design envisioned contains a second portion whose image is mirror symmetrical to the one shown. The embodiment shown is for the left side of the vehicle.

[56] References Cited

U.S. PATENT DOCUMENTS

D. 302,335 7/1989 Smith et al. D26/139
D. 308,108 5/1990 Sasamura D26/35
D. 308,422 6/1990 Sasamura D26/35

1 Claim, 2 Drawing Sheets

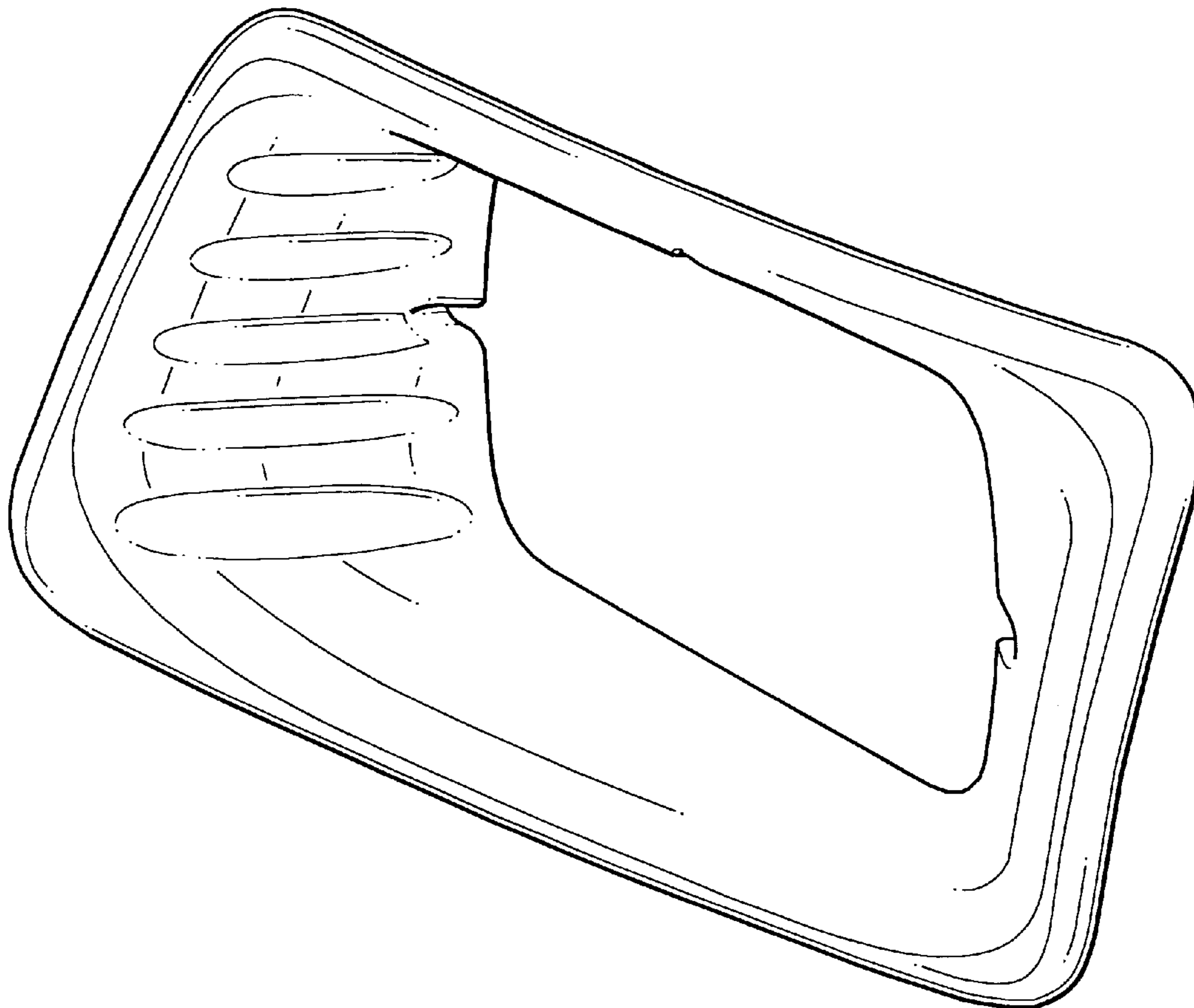

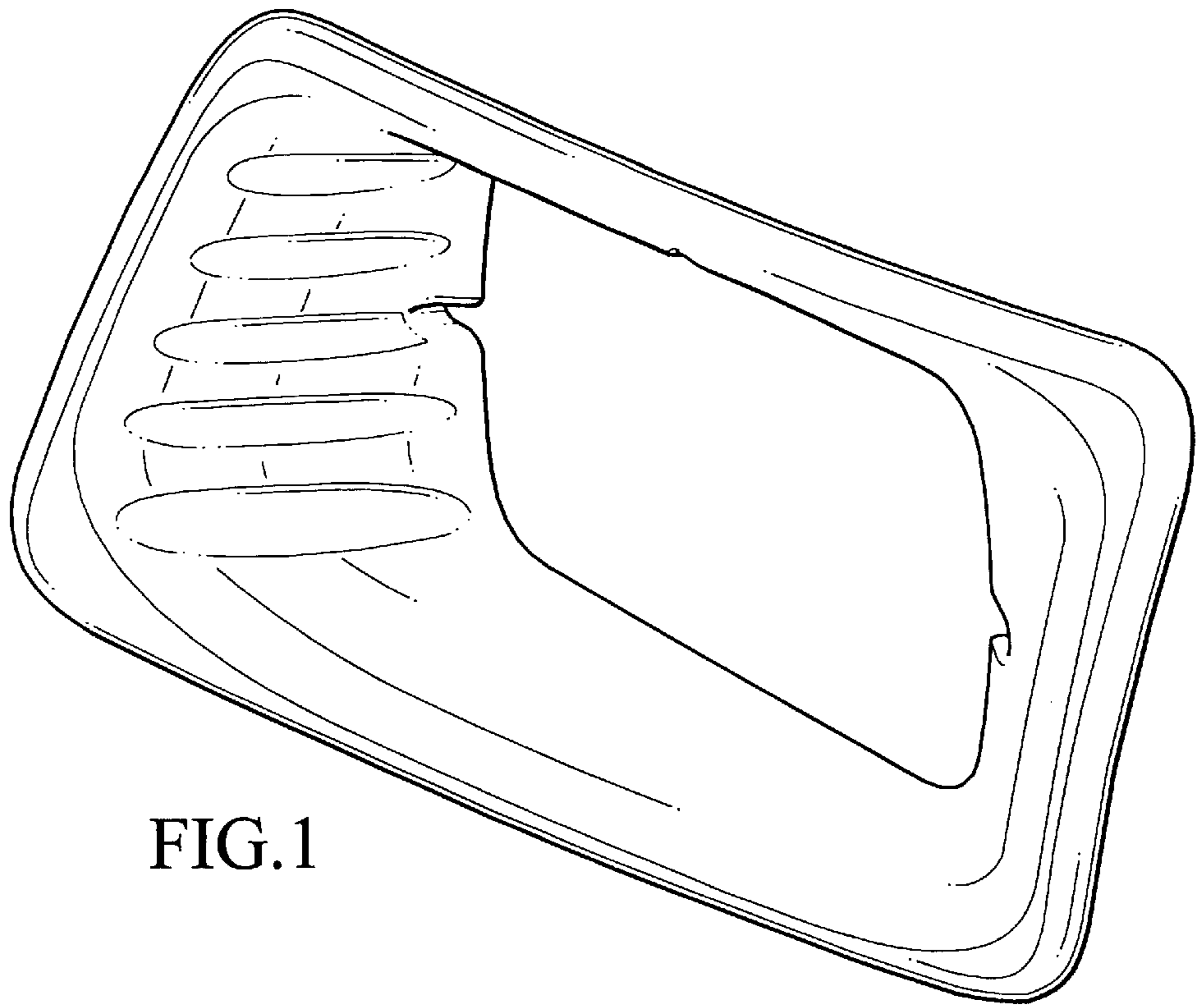

FIG.1

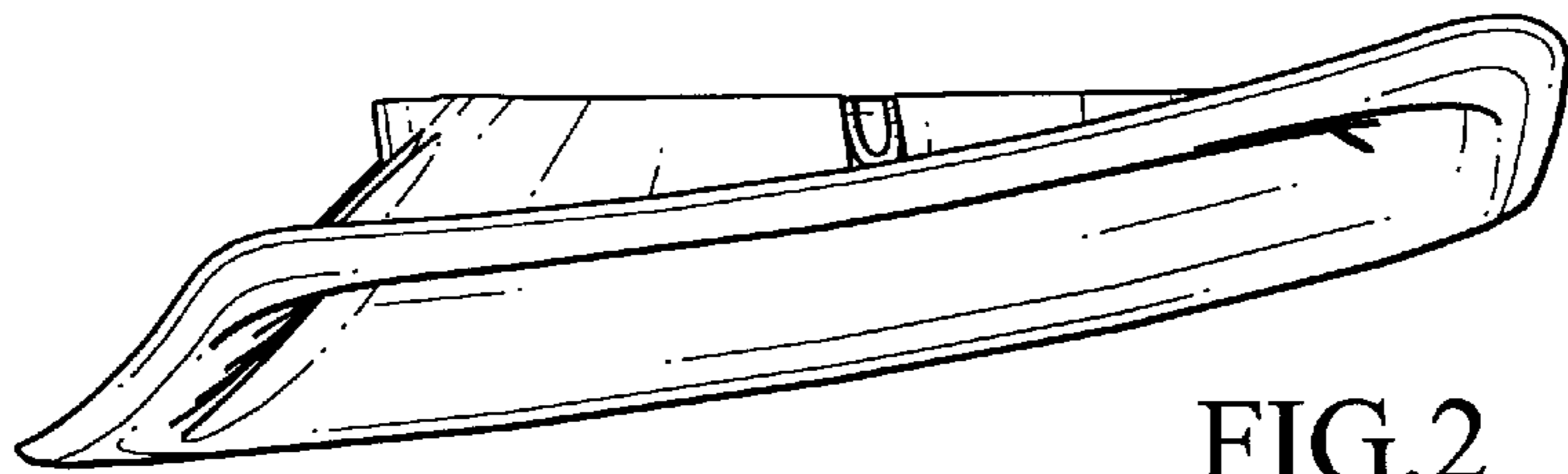

FIG.2

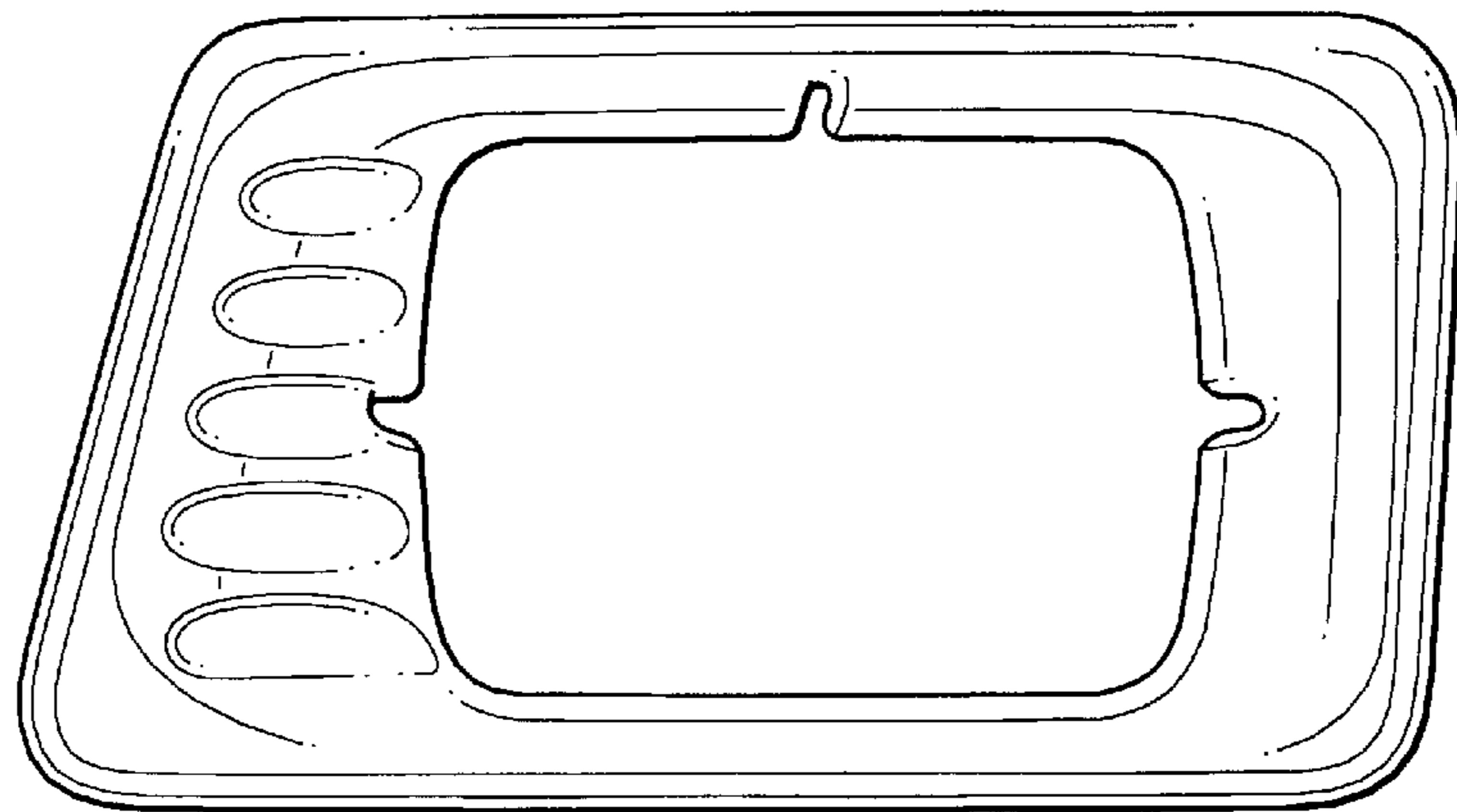

FIG.3

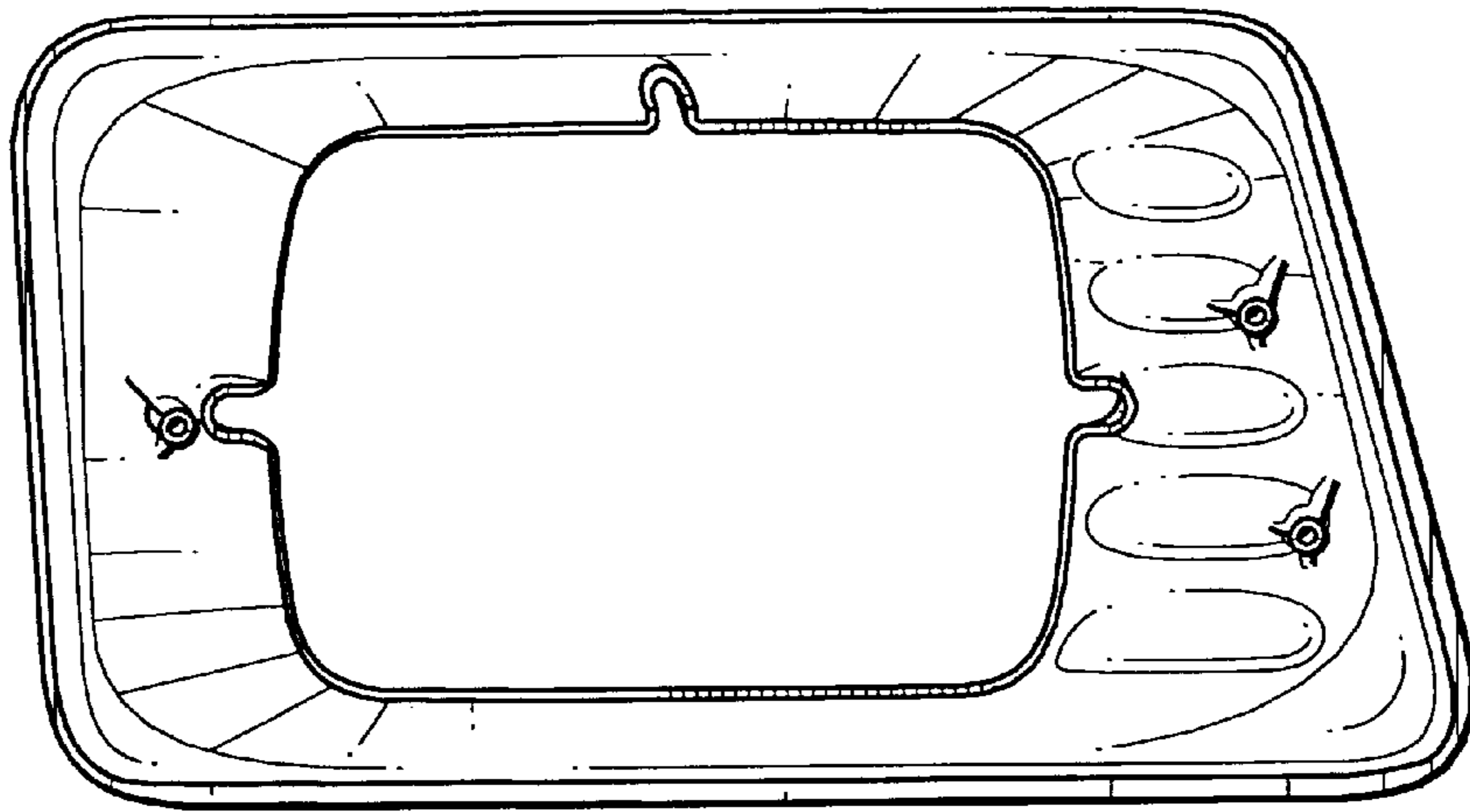

FIG. 4

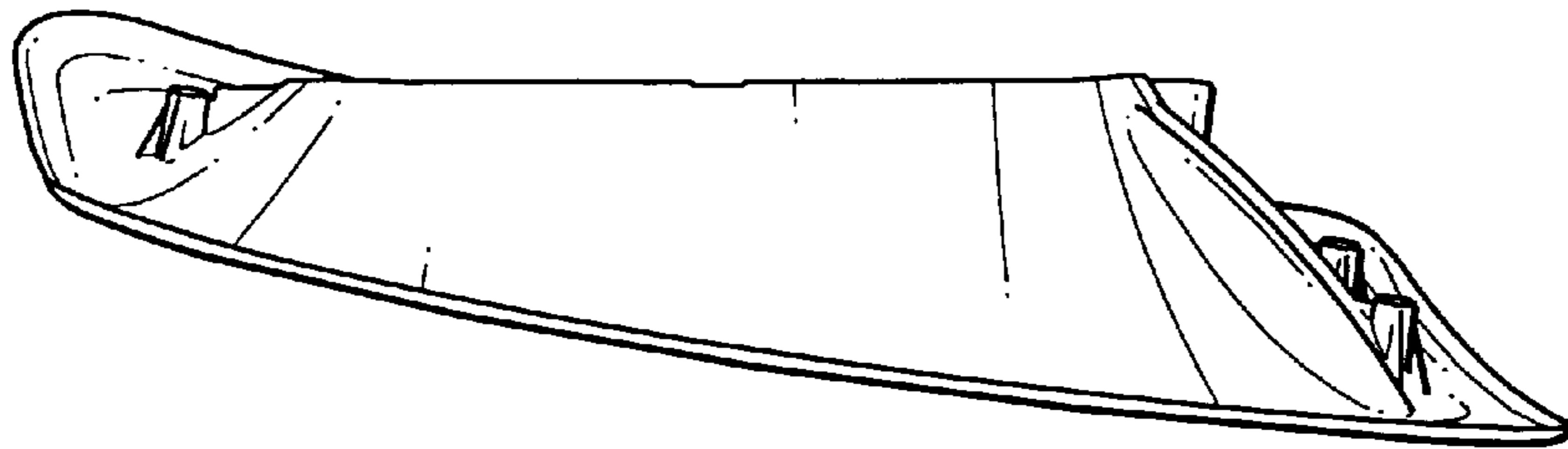

FIG. 5

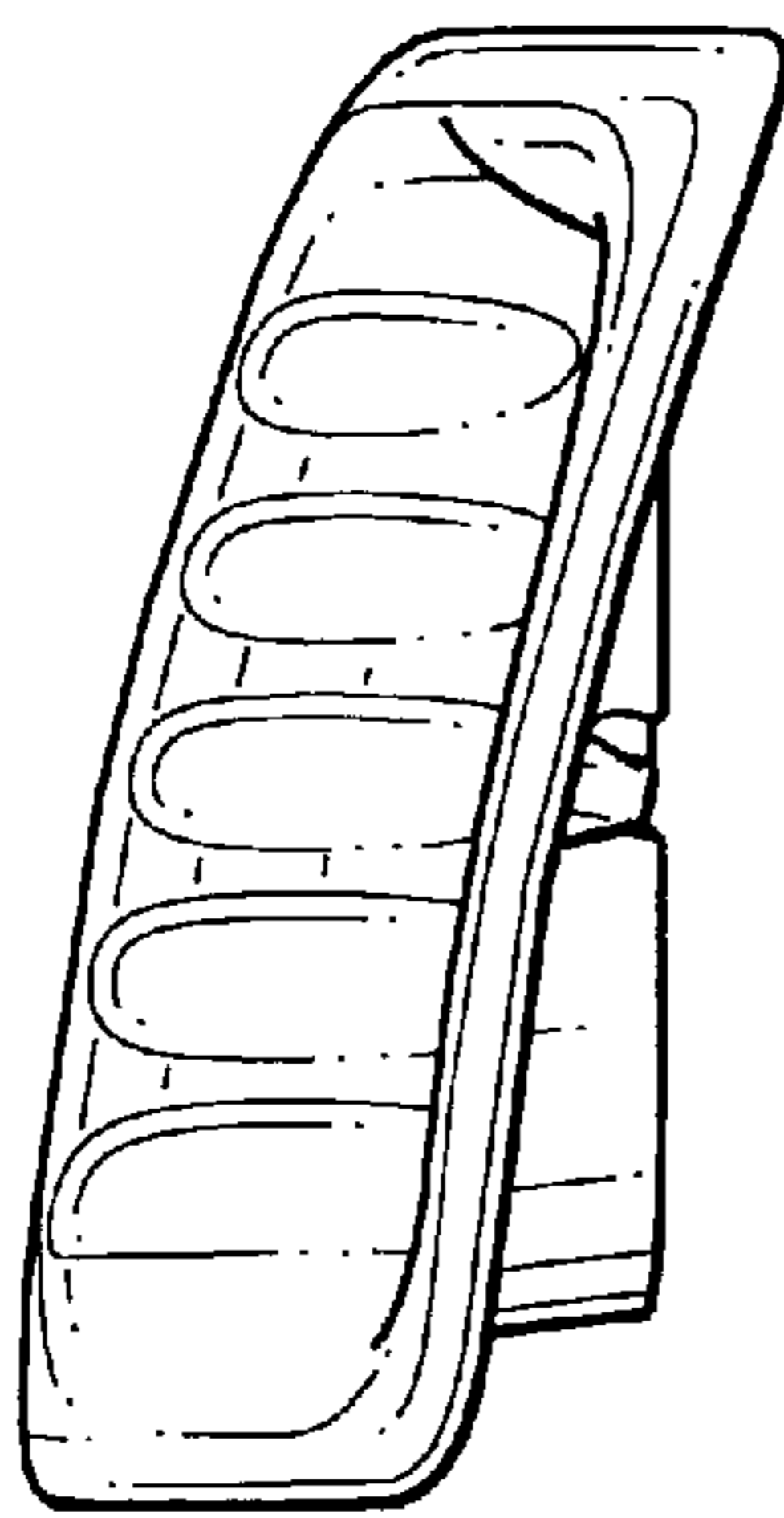

FIG. 6

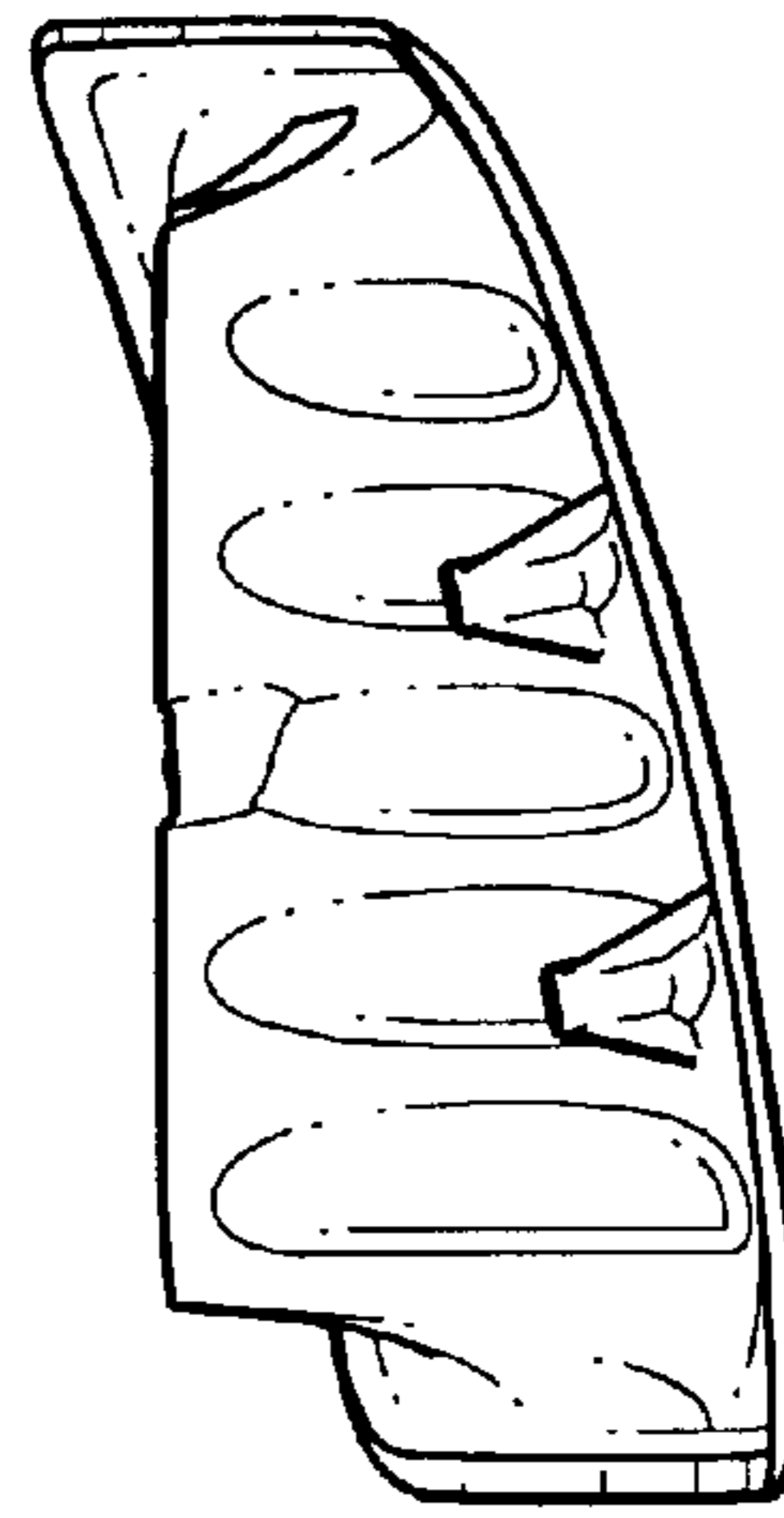

FIG. 7