



US00D421753S

United States Patent [19] Ishii

[11] **Patent Number: Des. 421,753**
[45] **Date of Patent: ** Mar. 21, 2000**

[54] **TAPE PLAYER**

[75] Inventor: **Daisuke Ishii**, Tokyo, Japan

[73] Assignee: **Sony Corporation**, Tokyo, Japan

[**] Term: **14 Years**

[21] Appl. No.: **29/077,875**

[22] Filed: **Oct. 10, 1997**

Related U.S. Application Data

[63] Continuation-in-part of application No. 29/065,287, Jan. 31, 1997, abandoned, application No. 29/065,286, Jan. 31, 1997, abandoned, and application No. 29/065,282, Jan. 31, 1997, abandoned.

[51] **LOC (6) Cl.** **14-01**

[52] **U.S. Cl.** **D14/165**

[58] **Field of Search** D14/124, 160-165,
D14/167-168, 188, 192-198; 455/344,
347-351

[56] References Cited

U.S. PATENT DOCUMENTS

- D. 305,762 1/1990 Yoda et al. D14/163
- D. 312,638 12/1990 Hino et al. D14/161 X
- D. 319,238 8/1991 Taniguchi D14/161 X
- D. 330,552 10/1992 Tsuchiya D14/165
- D. 336,297 6/1993 Sekita D14/165

- D. 347,843 6/1994 Iribe et al. D14/165
- D. 349,114 7/1994 Nakamura D14/163
- D. 370,912 6/1996 Ohba et al. D14/165
- D. 374,231 10/1996 Matsuzaka D14/163
- 5,452,274 9/1995 Thompson D14/163 X

OTHER PUBLICATIONS

Design 460, p. 24, Sharp tape recorder (located in examiner's office), Apr. 1987.

Primary Examiner—Nanda Bondade
Attorney, Agent, or Firm—Foley & Lardner

[57] CLAIM

The ornamental design for a tape player, as shown and described.

DESCRIPTION

FIG. 1 is a top front perspective view of a tape player showing my new design;
 FIG. 2 is a top rear perspective view thereof, wherein, the cover portion is in the open position;
 FIG. 3 is a top plan view of FIG. 1;
 FIG. 4 is a left side elevational view thereof;
 FIG. 5 is a front elevational view thereof;
 FIG. 6 is a bottom plan view thereof;
 FIG. 7 is a right side elevational view thereof; and,
 FIG. 8 is a rear elevational view thereof.

1 Claim, 4 Drawing Sheets

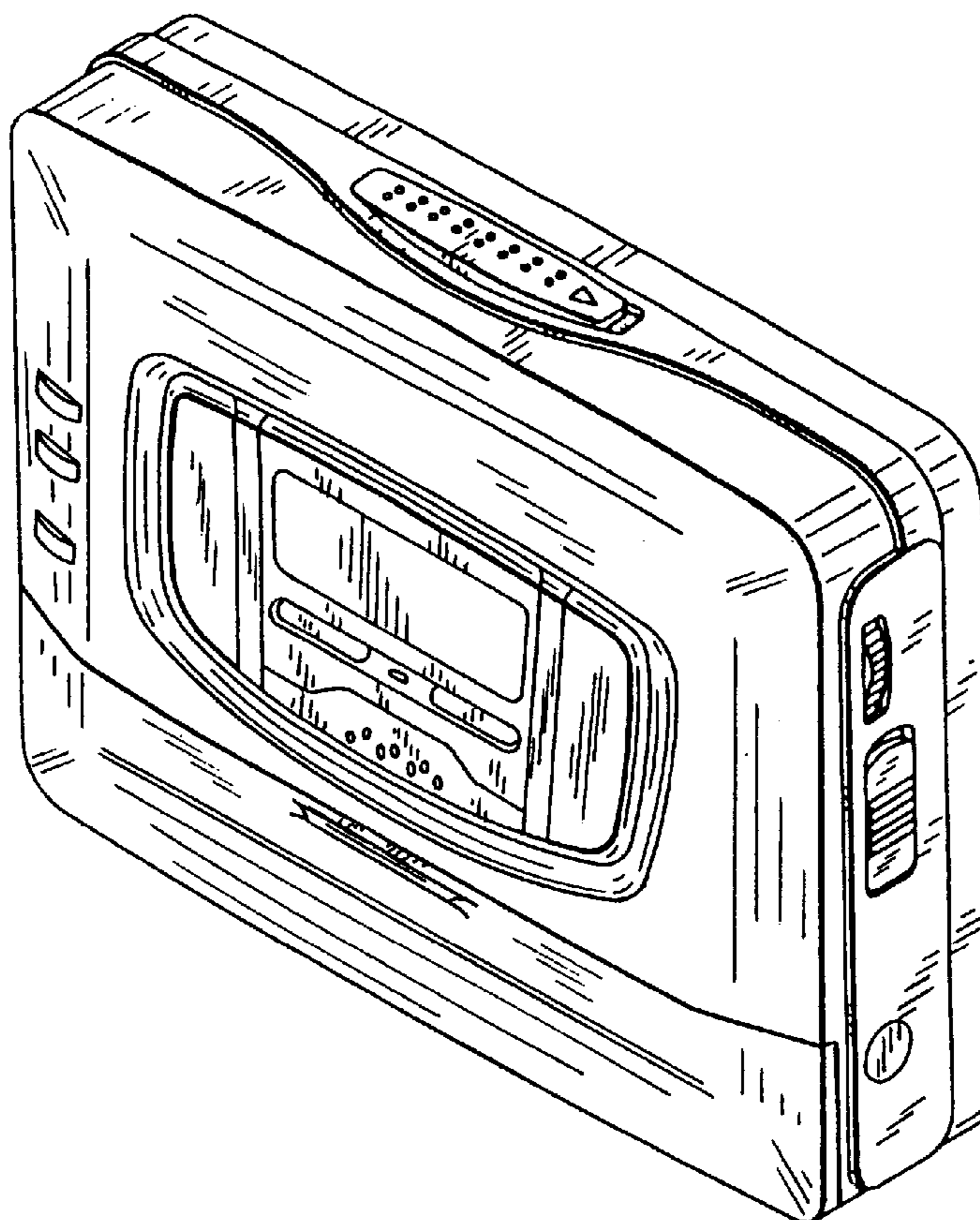

FIG. 1

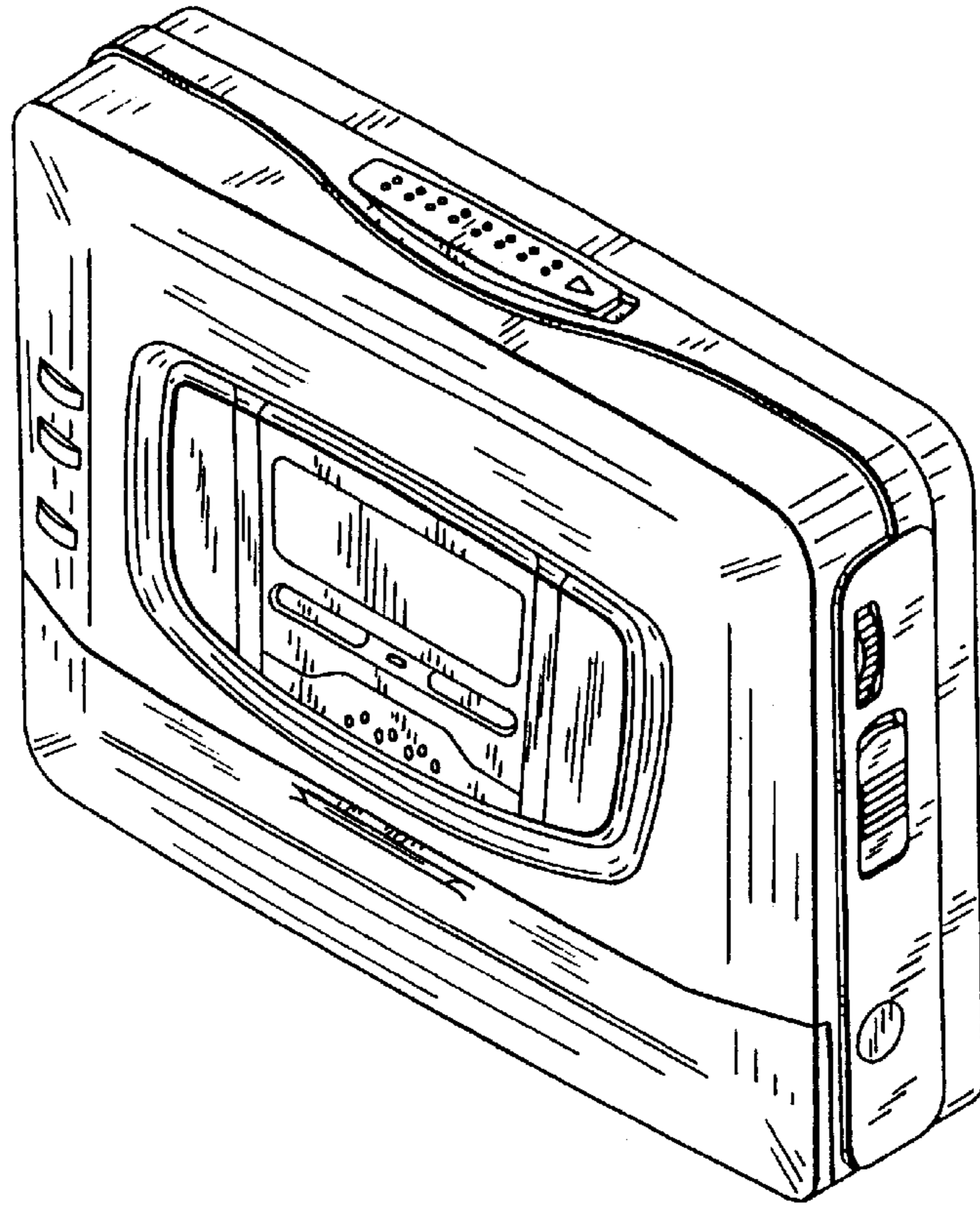

FIG. 2

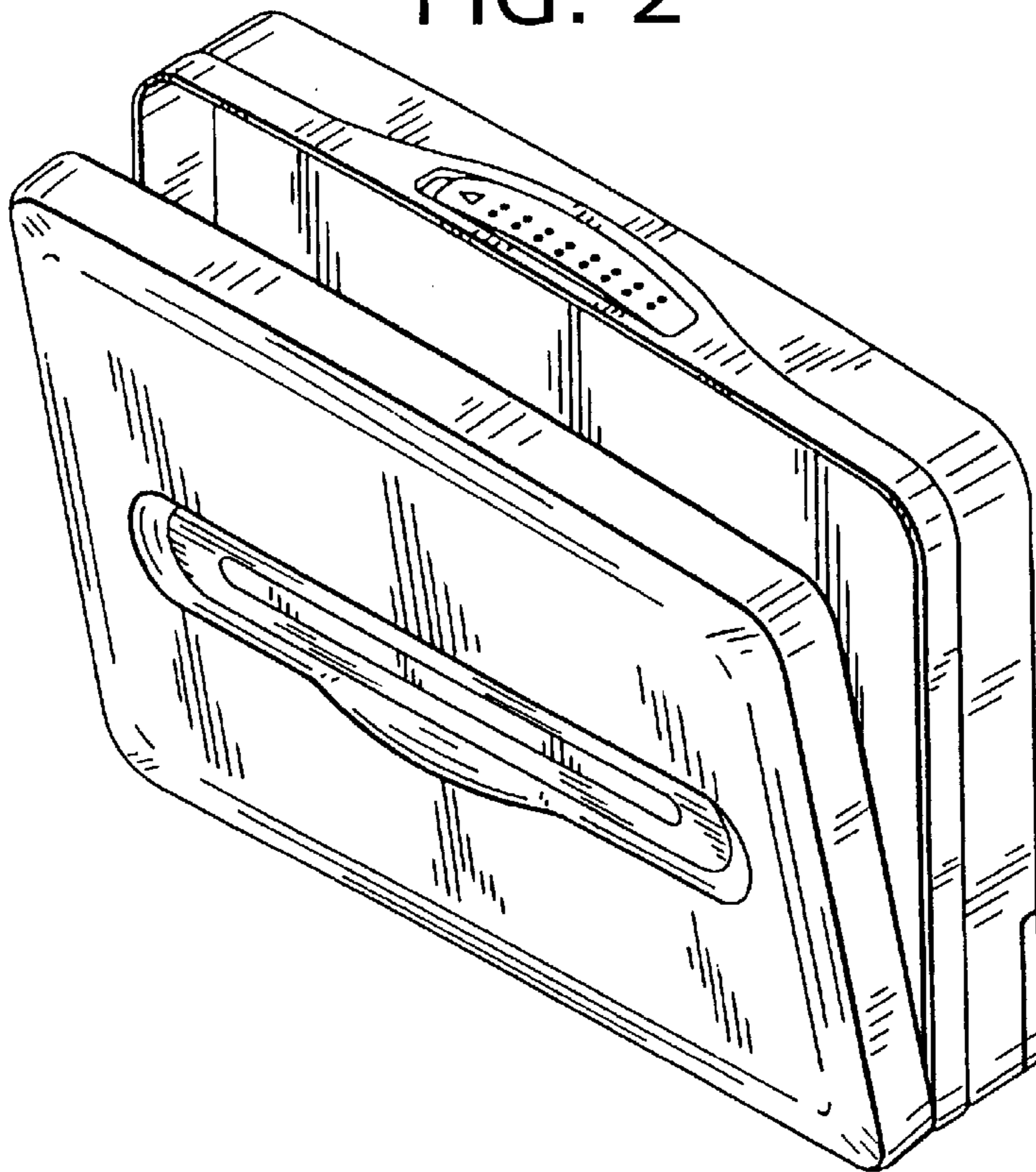

FIG. 3

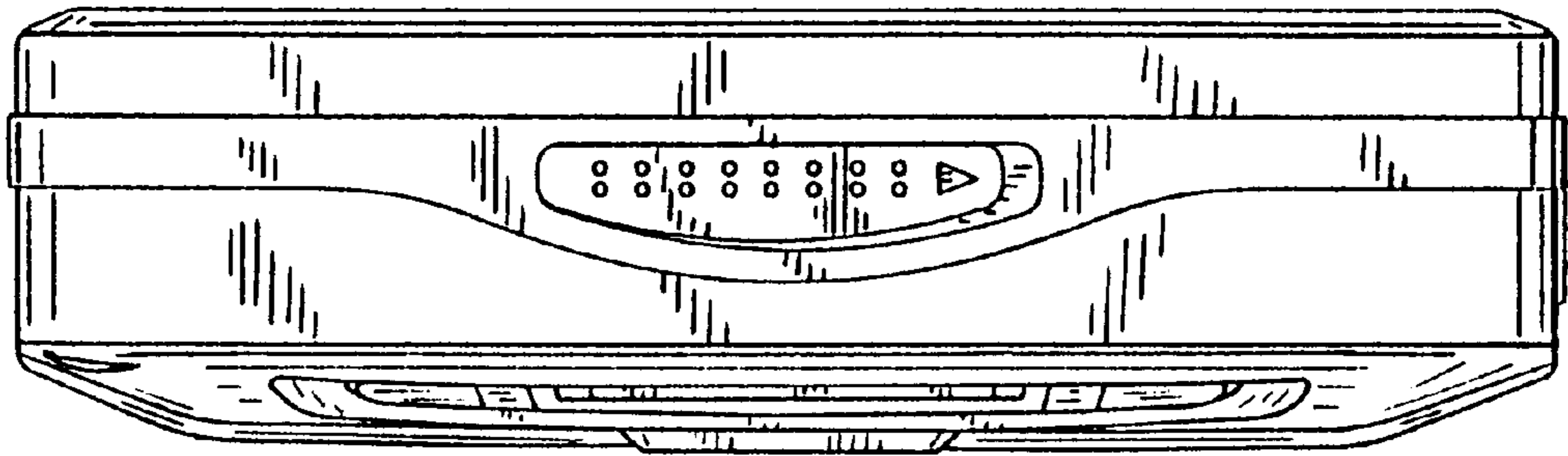

FIG. 5

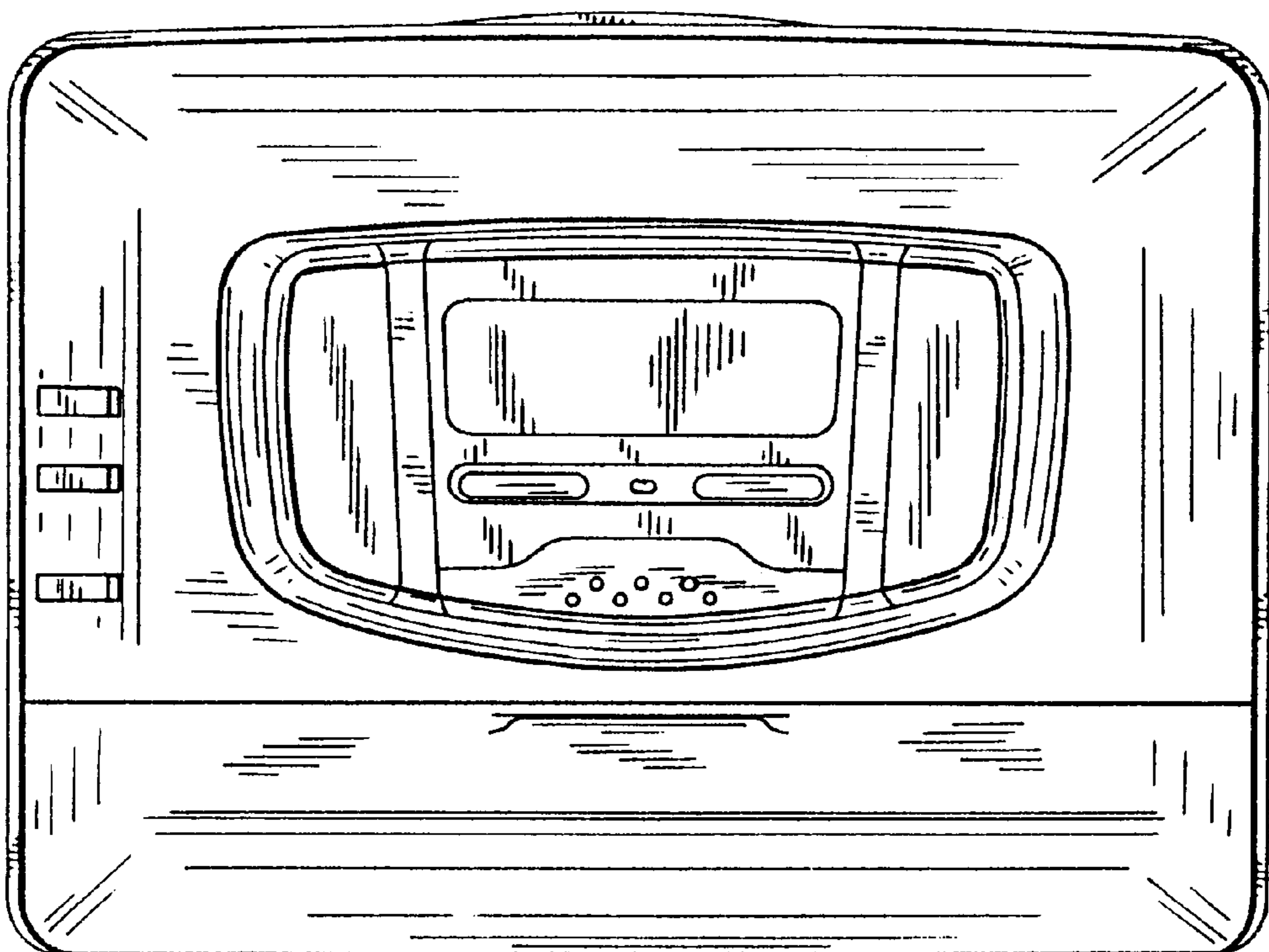

FIG. 4

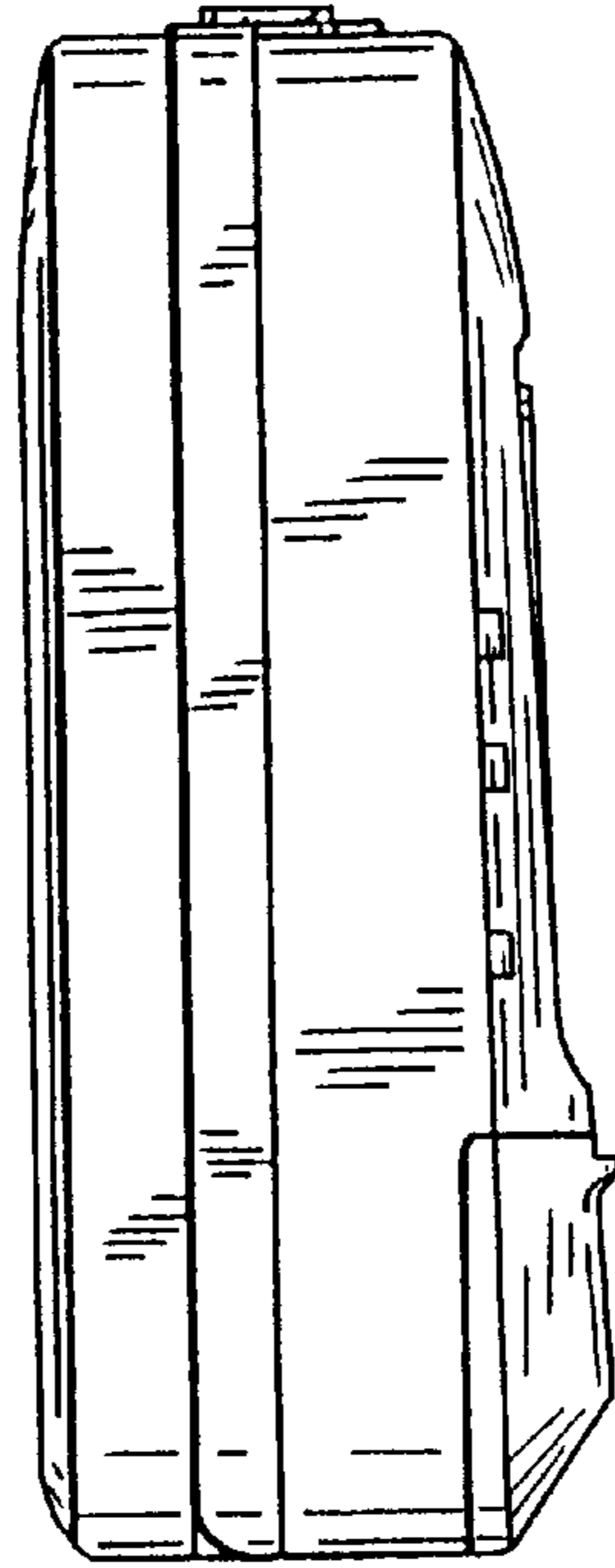

FIG. 7

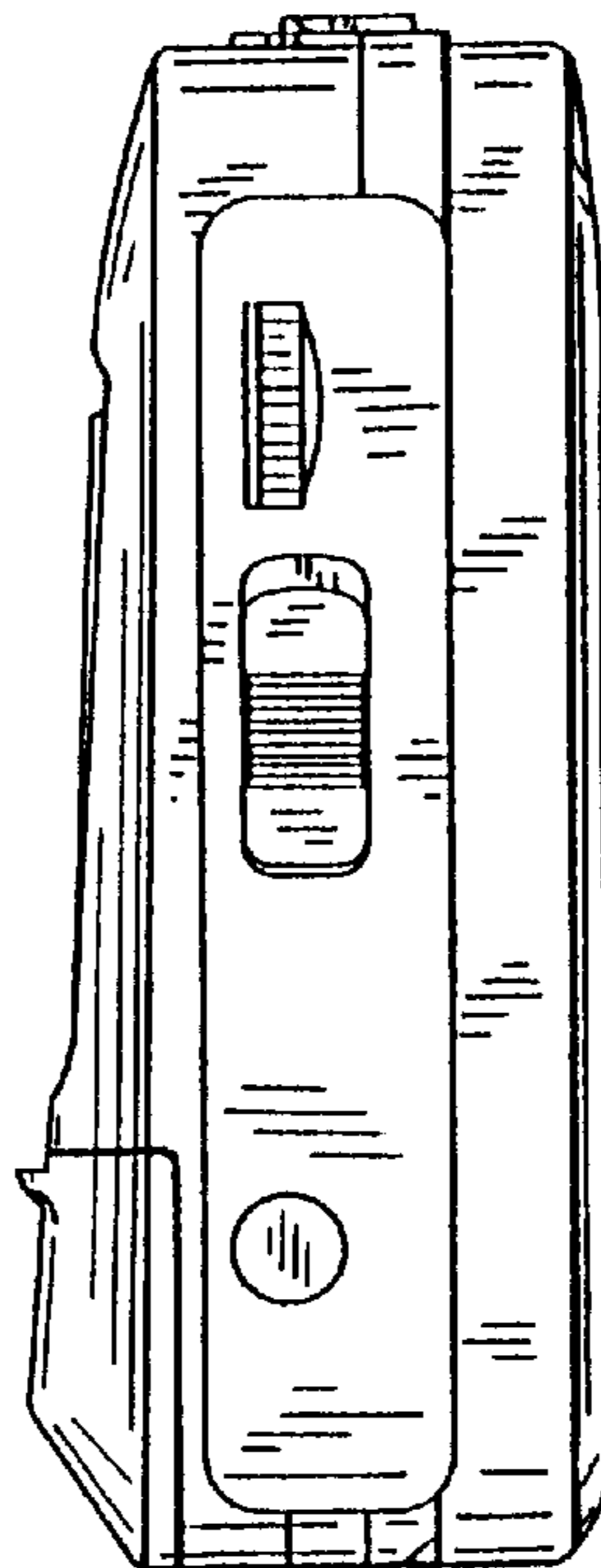

FIG. 6

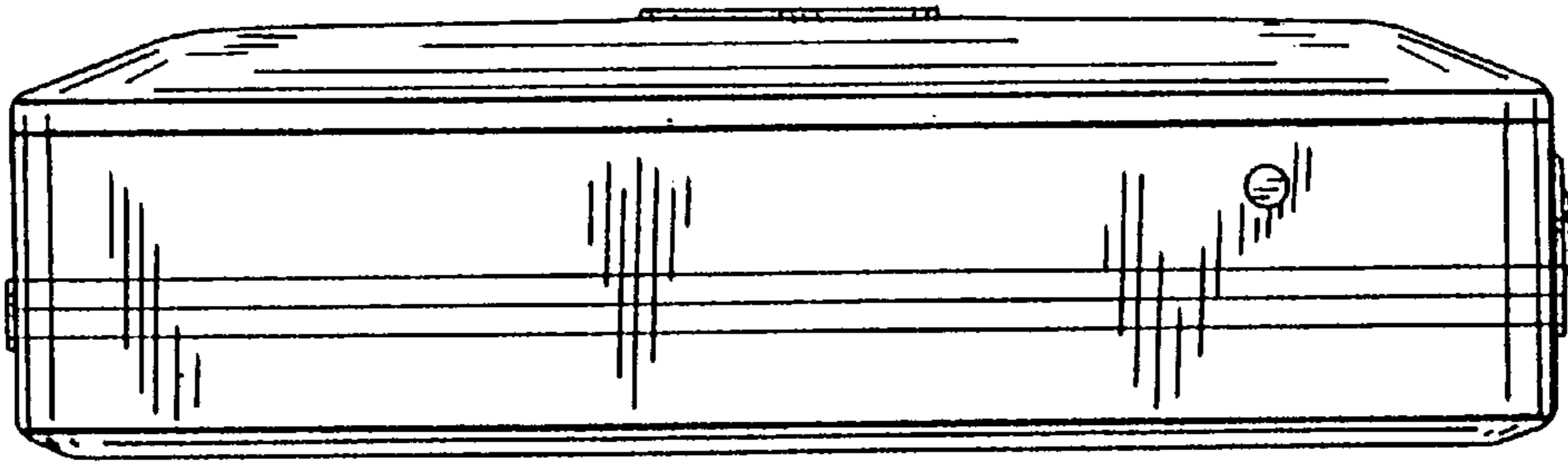

FIG. 8

