



US00D421740S

United States Patent [19]

[11] Patent Number: Des. 421,740

Peterson et al.

[45] Date of Patent: ** Mar. 21, 2000

[54] BATTERY CLAMP

[75] Inventors: **Keith A. Peterson; Yasu Yamamoto,**
both of Portland, Oreg.

[73] Assignee: **Phoenix Gold International, Inc.,**
Portland, Oreg.

[**] Term: **14 Years**

[21] Appl. No.: **29/096,751**

[22] Filed: **Nov. 2, 1998**

[51] LOC (6) Cl. **13-03**

[52] U.S. Cl. **D13/120**

[58] Field of Search D13/120; 439/761,
439/763, 764, 765, 797, 798

[56] References Cited

U.S. PATENT DOCUMENTS

D. 361,750	8/1995	Ansley	D13/151
D. 399,487	10/1998	Awbrey et al.	D13/120
D. 409,977	5/1999	Liang	D13/120
5,171,169	12/1992	Butcher et al.	439/763 X
5,190,484	3/1993	Kennedy	439/761
5,718,610	2/1998	Faber	439/797

OTHER PUBLICATIONS

Audio/Car Audio '96-'97 Accessory Pricing Schedule, pp.
6, 32-33 (1996).

Primary Examiner—Joel Sincavage
Attorney, Agent, or Firm—Klarquist Sparkman Campbell
Leigh & Winston, LLP

[57] CLAIM

The ornamental design for a battery clamp, as shown and described.

DESCRIPTION

FIG. 1 is a top perspective view of a first embodiment of a battery clamp showing our new design.

FIG. 2 is a top plan view of the battery clamp of FIG. 1, with the front of the clamp on the right of the figure and the rear of the clamp on the left of the figure.

FIG. 3 is a left side elevational view of the battery clamp of FIG. 1.

FIG. 4 is a rear elevational view of the battery clamp of FIG. 1.

FIG. 5 is a right side elevational view of the battery clamp of FIG. 1.

FIG. 6 is a front elevational view of the battery clamp of FIG. 1.

FIG. 7 is a bottom plan view of the battery clamp of FIG. 1.

FIG. 8 is a top perspective view of a second embodiment of a battery clamp showing our new design.

FIG. 9 is a top plan view of the battery clamp of FIG. 8, with the front of the clamp on the right of the figure and the rear of the clamp on the left of the figure.

FIG. 10 is a left side elevational view of the battery clamp of FIG. 8.

FIG. 11 is a rear elevational view of the battery clamp of FIG. 8.

FIG. 12 is a right side elevational view of the battery clamp of FIG. 8.

FIG. 13 is a front elevational view of the battery clamp of FIG. 8; and,

FIG. 14 is a bottom plan view of the battery clamp of FIG. 8.

1 Claim, 4 Drawing Sheets

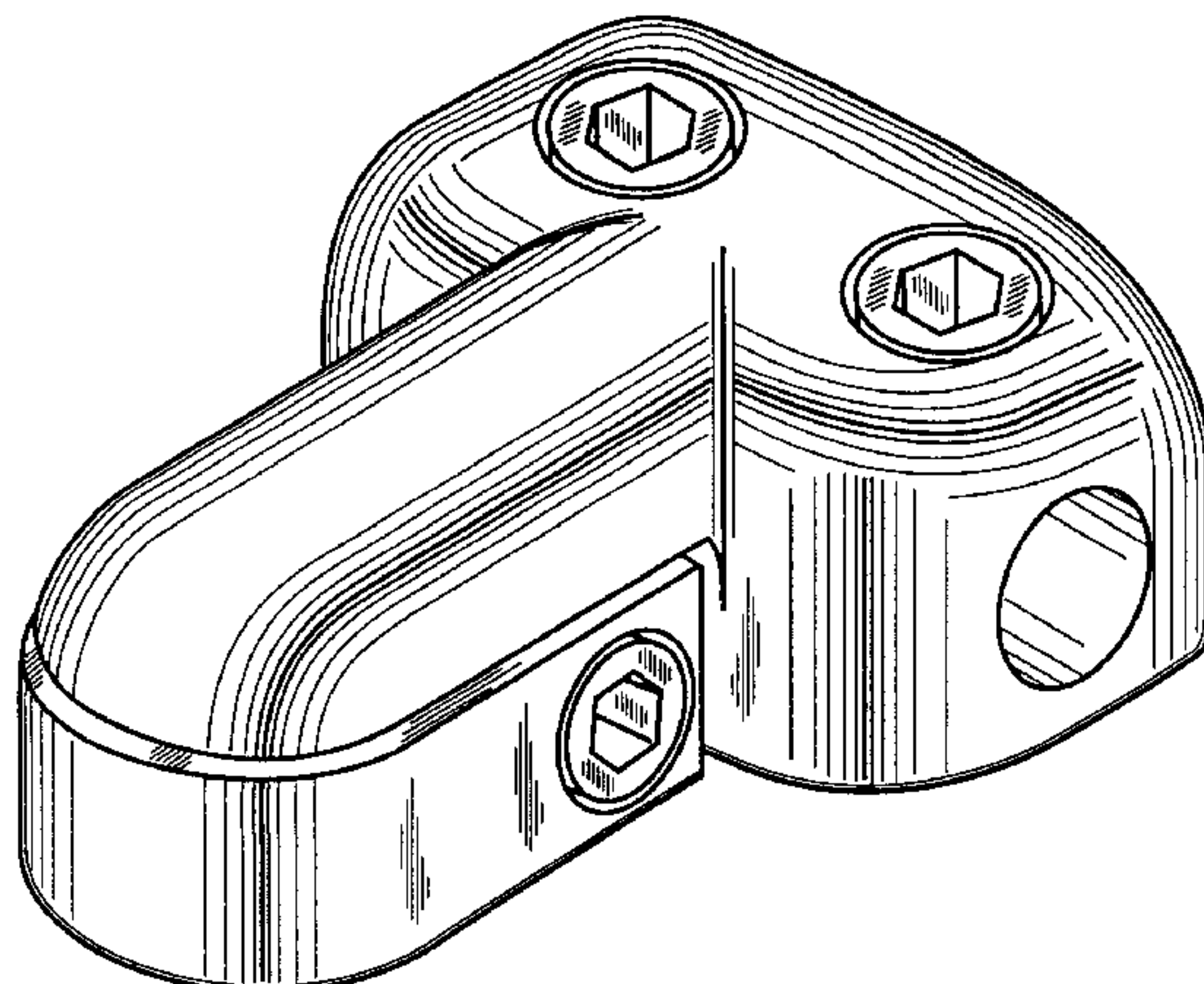

FIG. 1

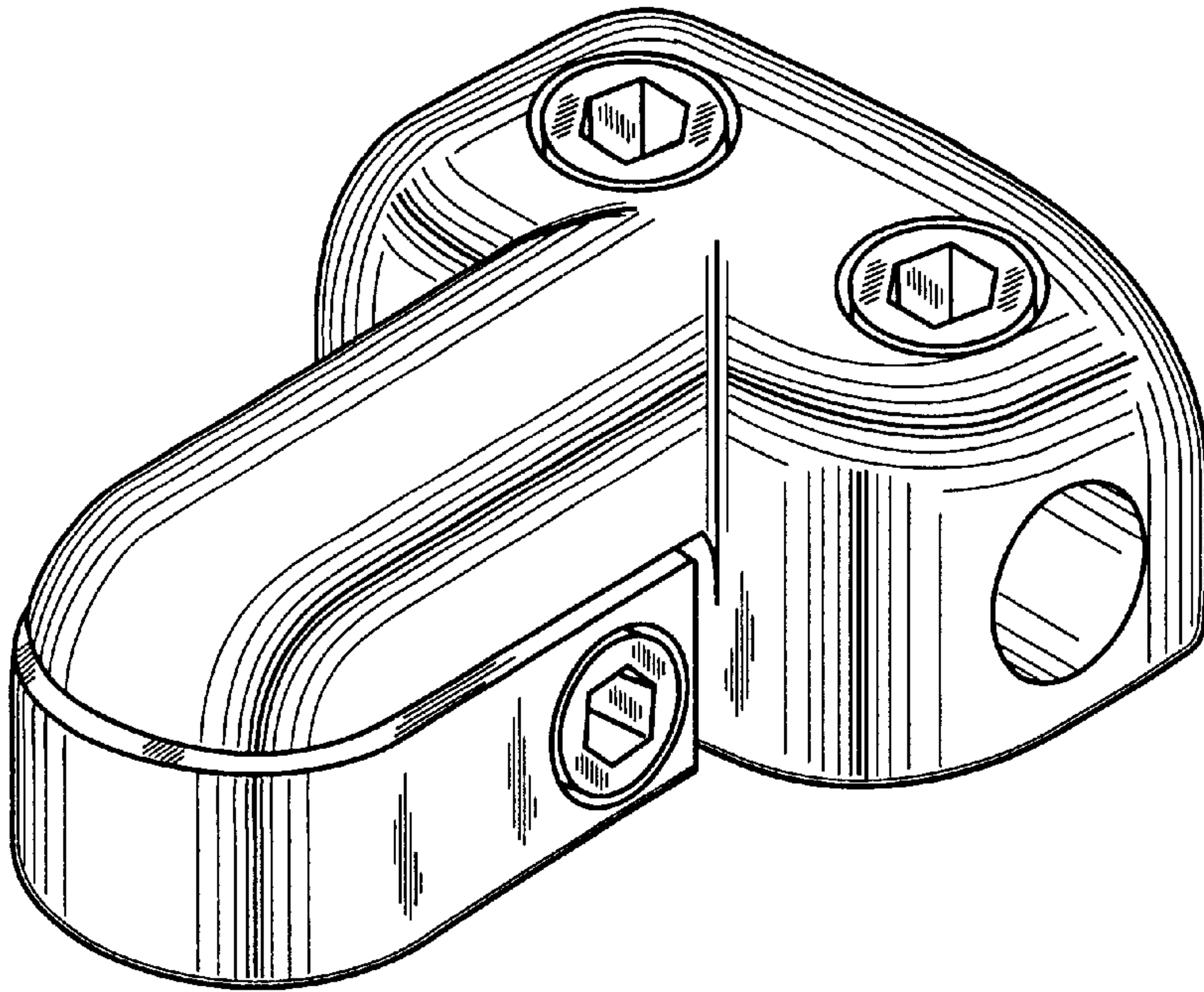

FIG. 2

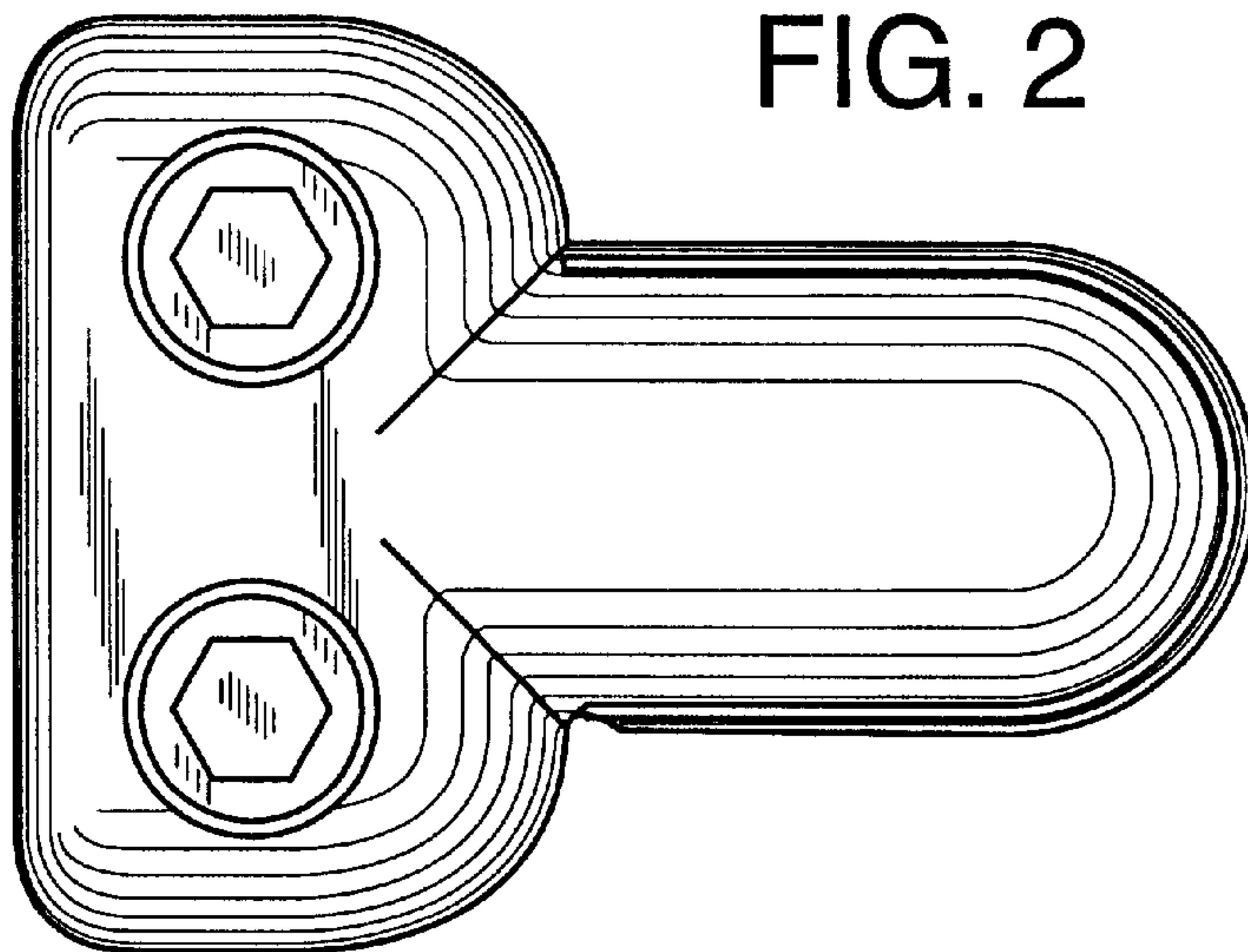

FIG. 3

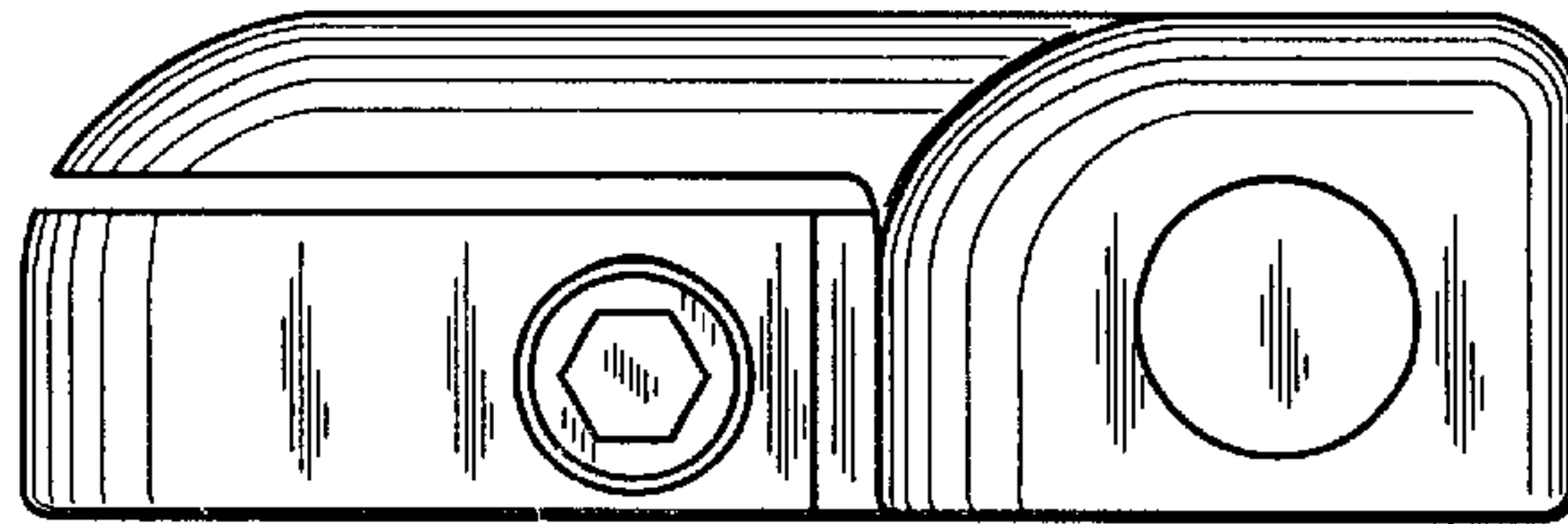

FIG. 4

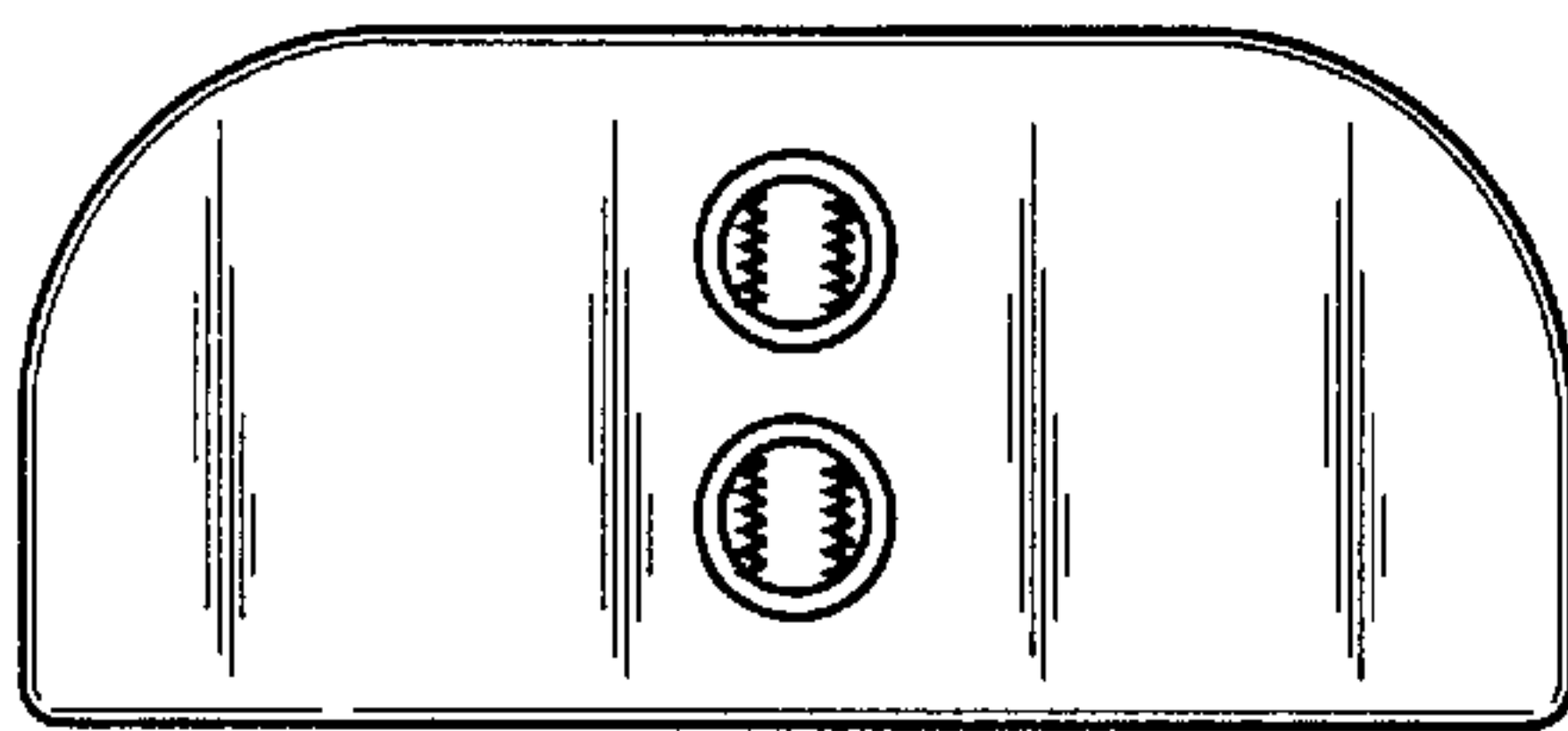

FIG. 5

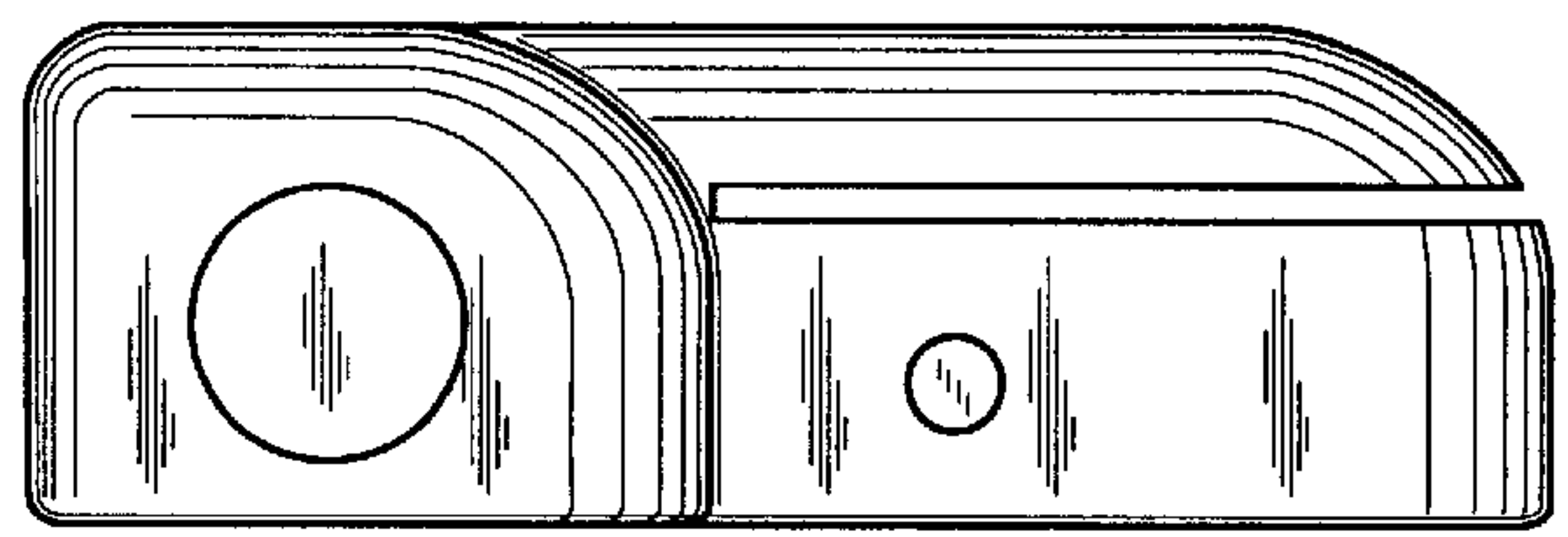

FIG. 6

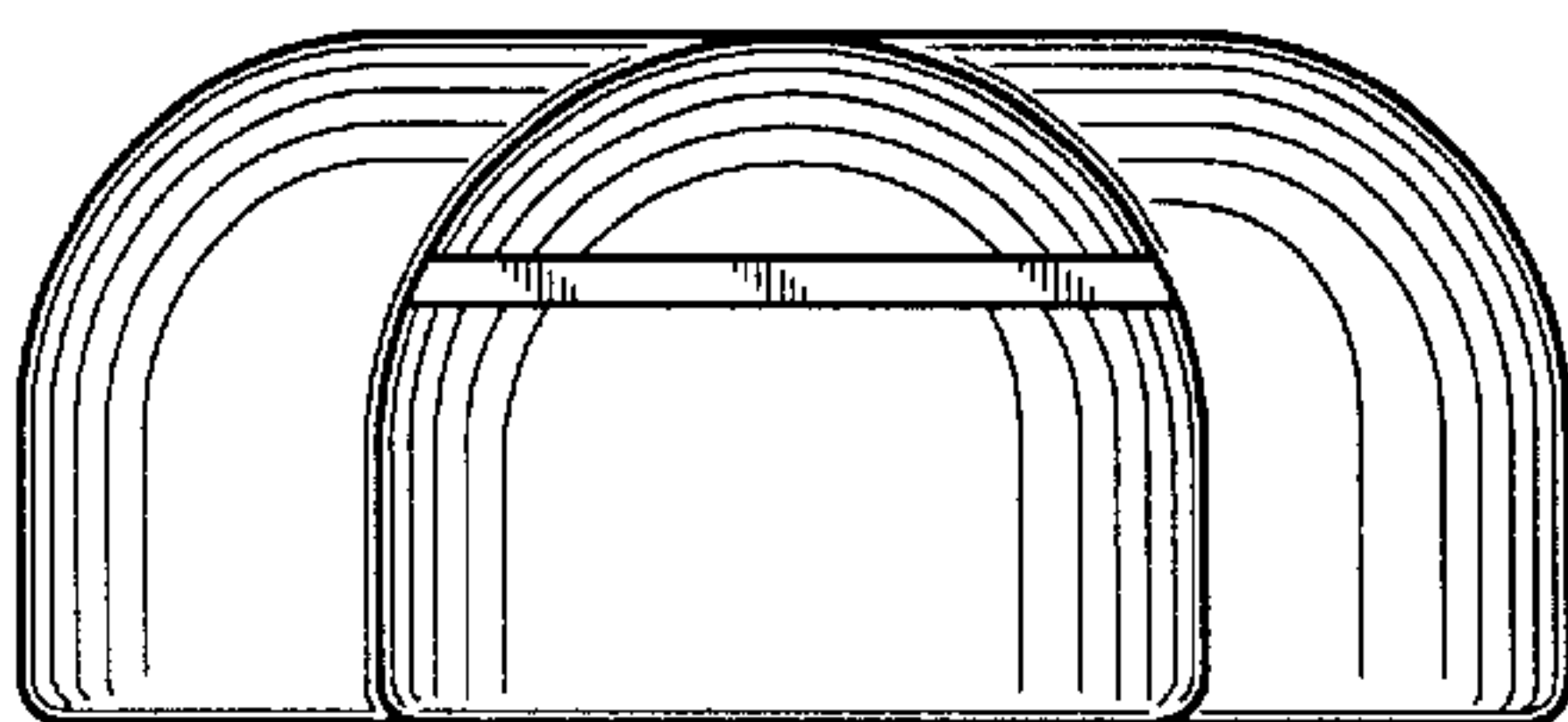

FIG. 7

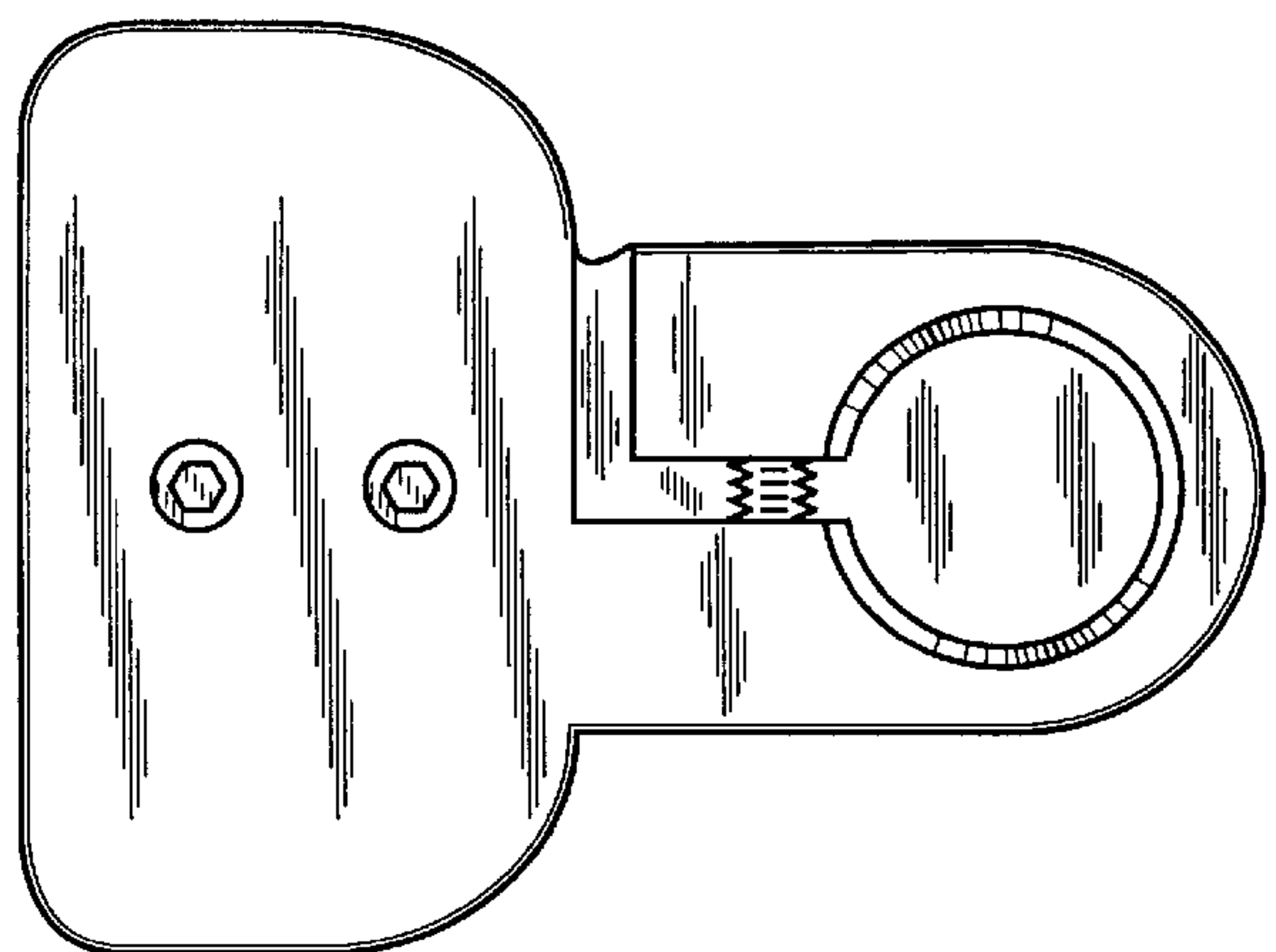

FIG. 8

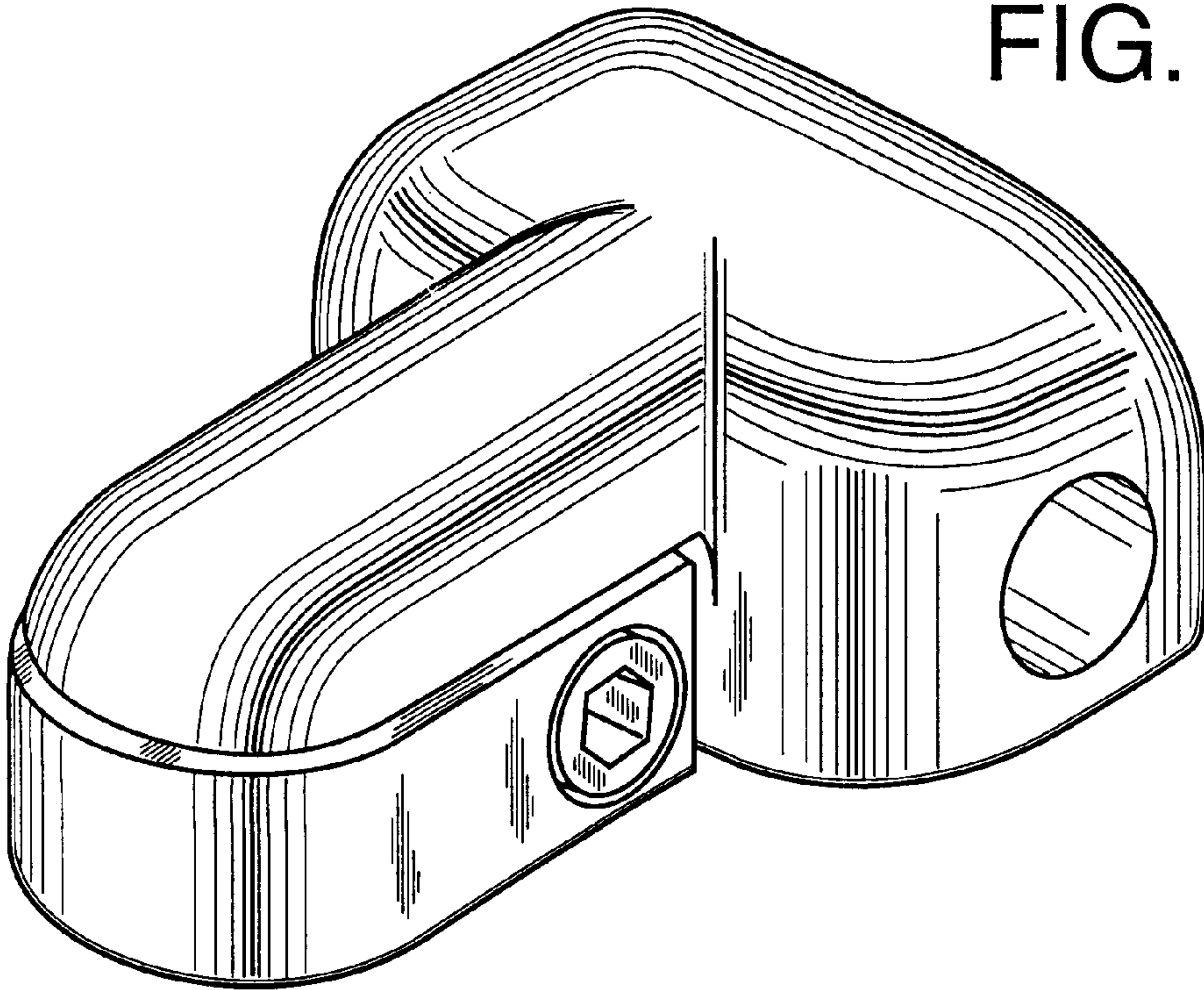

FIG. 9

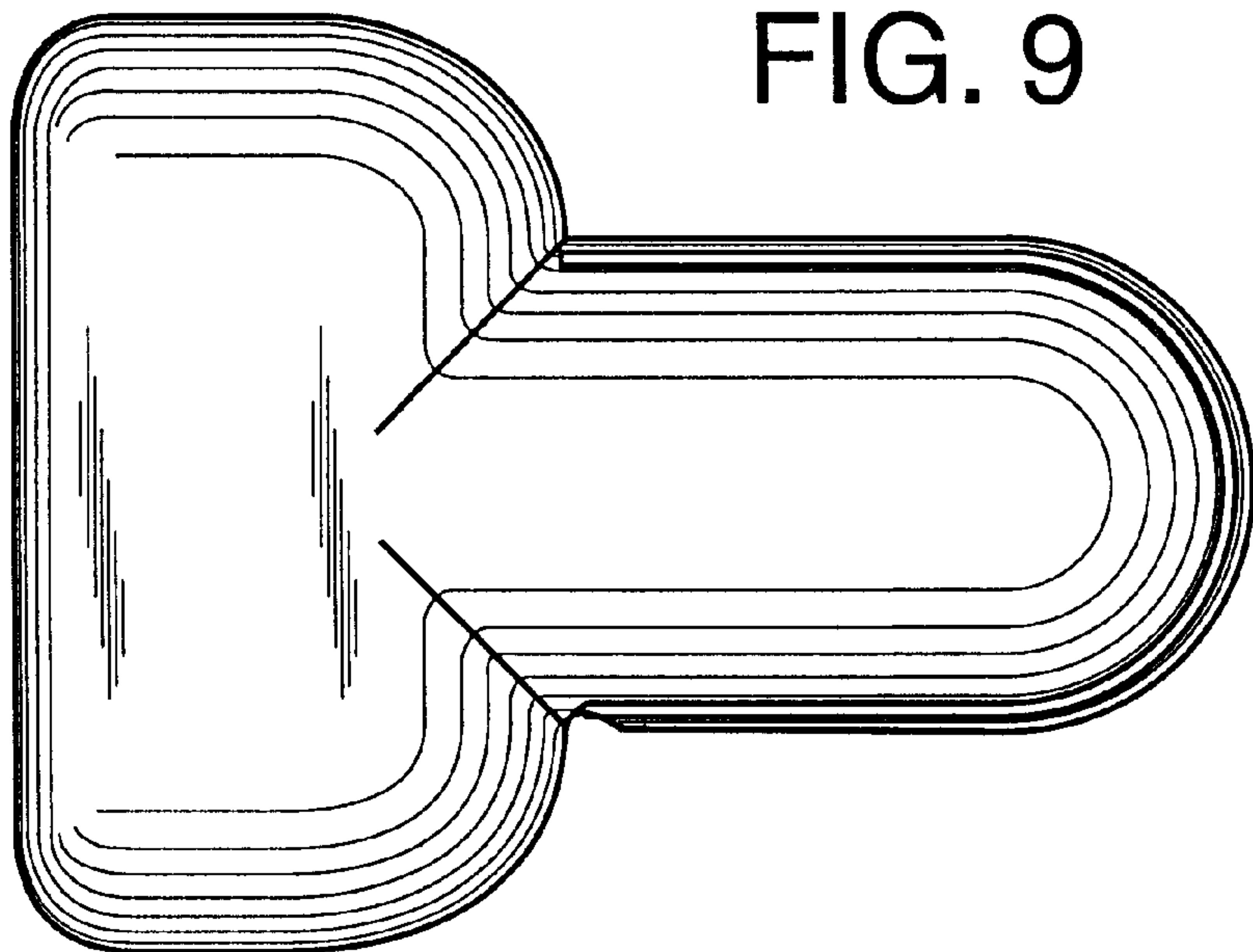

FIG. 10

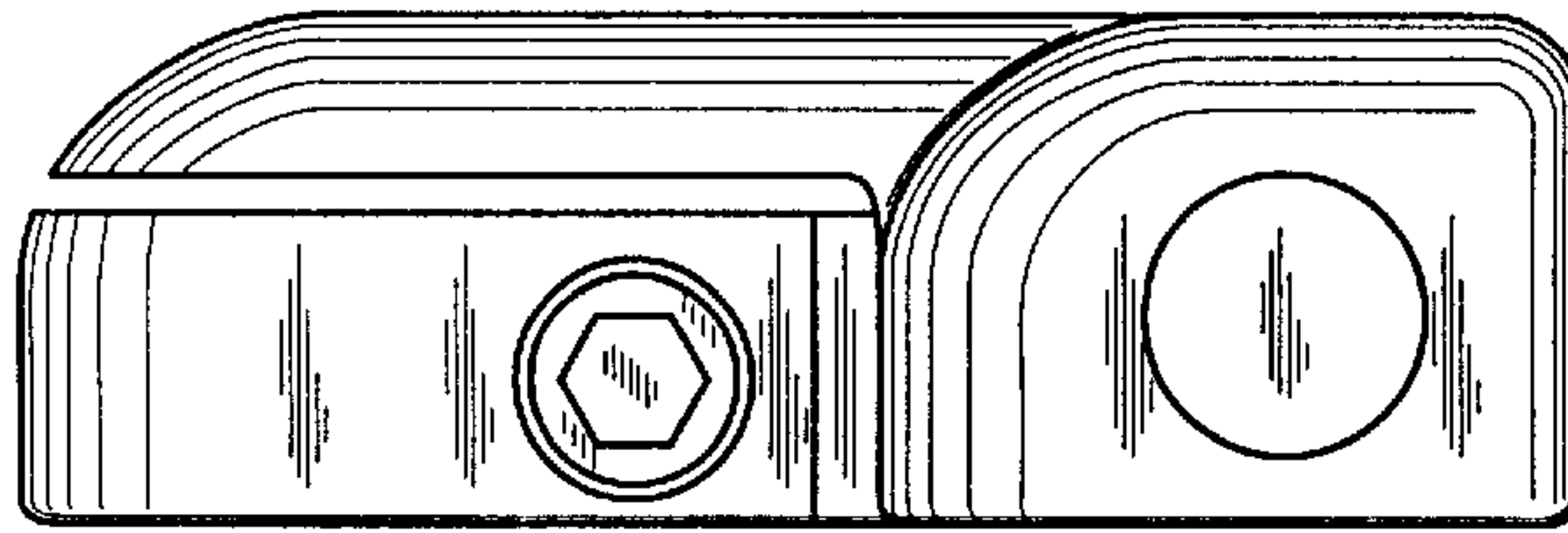

FIG. 11

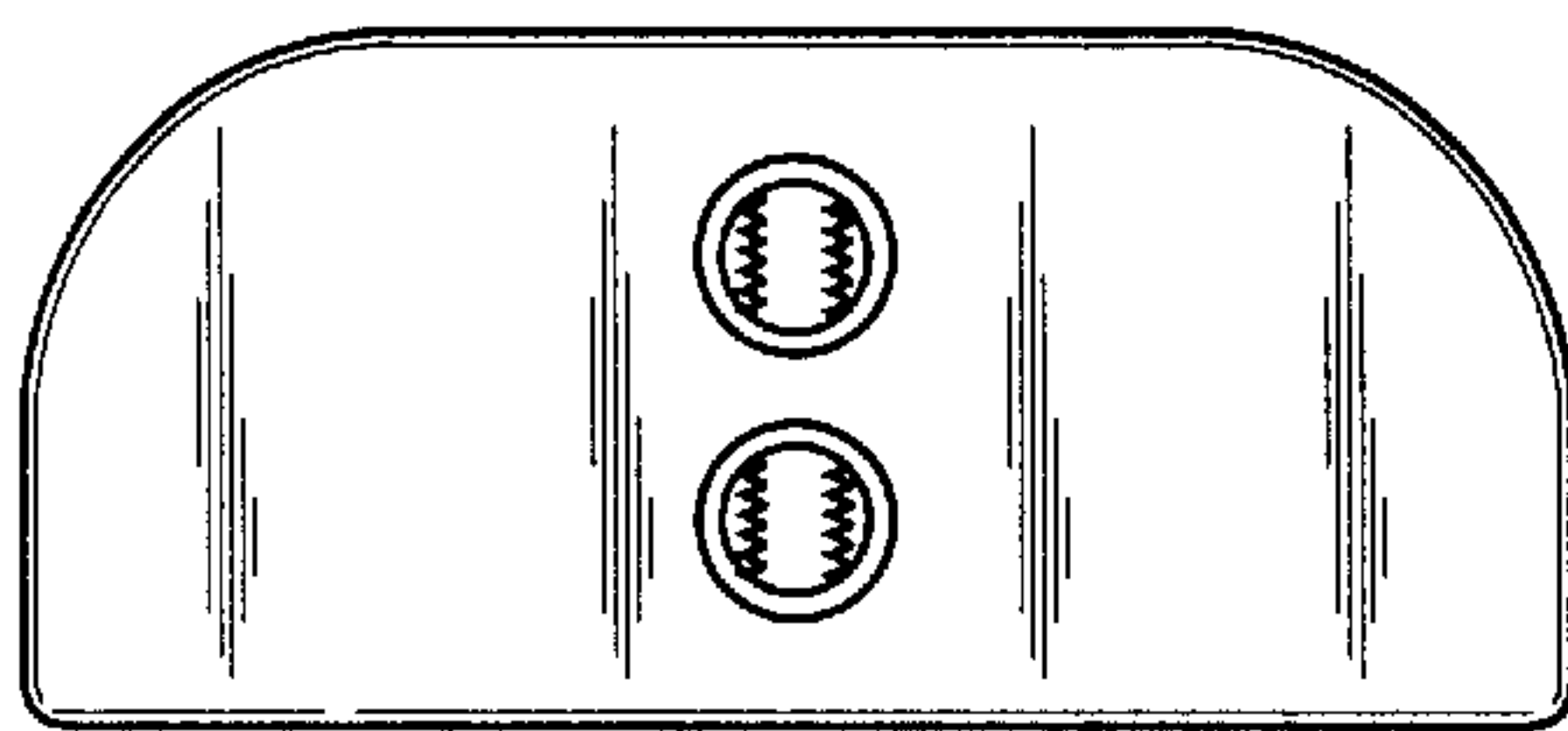

FIG. 12

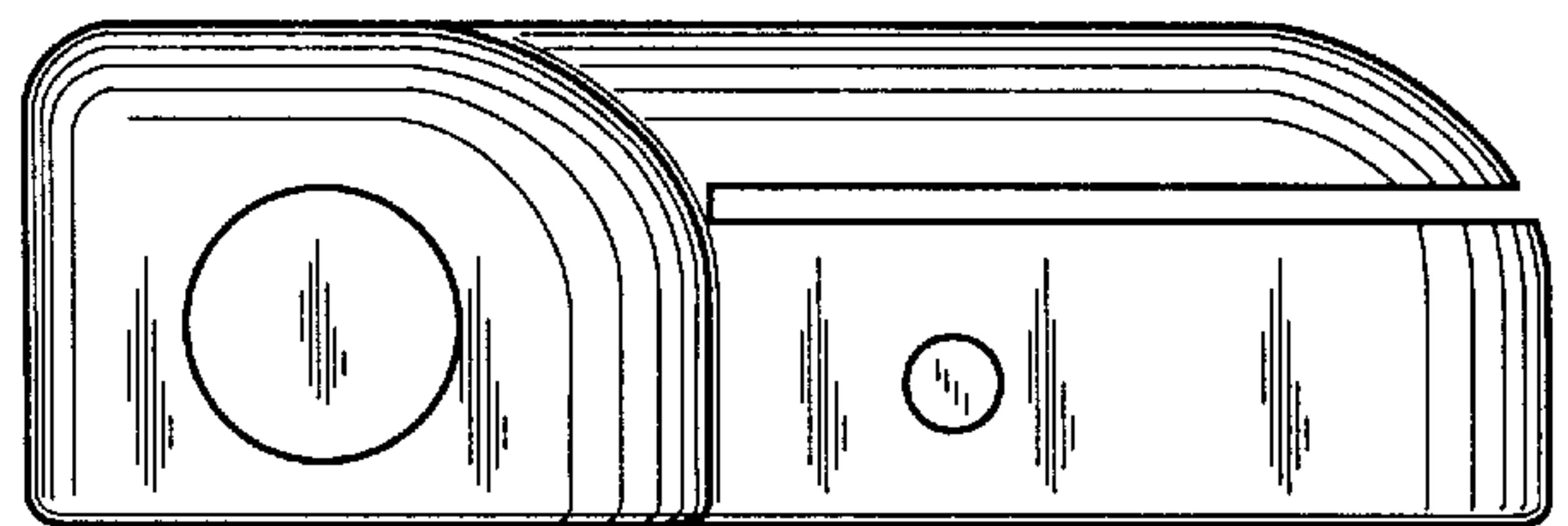

FIG. 13

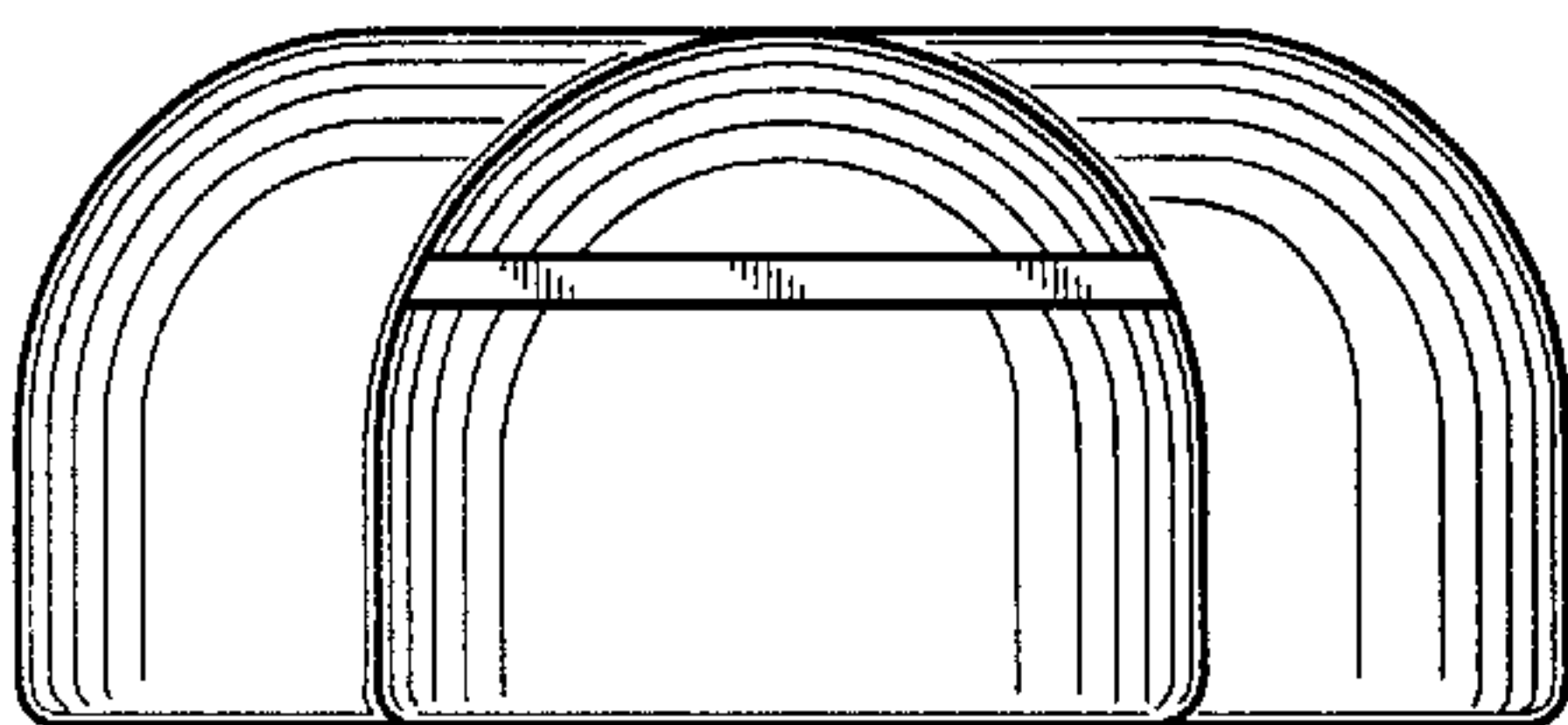

FIG. 14

