



US00D421704S

United States Patent [19]
Hasegawa

[11] **Patent Number: Des. 421,704**

[45] **Date of Patent: ** Mar. 21, 2000**

[54] **SPIKED FEEDING WHEEL FOR USE IN A BOARD SPLITTING APPARATUS**

[75] Inventor: **Katsuji Hasegawa**, Ohbu, Japan

[73] Assignee: **Meinan Machinery Works, Inc.**, Aichi-ken, Japan

[**] Term: **14 Years**

[21] Appl. No.: **29/097,668**

[22] Filed: **Dec. 11, 1998**

[30] **Foreign Application Priority Data**

Jun. 26, 1998	[JP]	Japan	10-18579
Jun. 26, 1998	[JP]	Japan	10-18580

[51] **LOC (6) Cl.** **08-03**

[52] **U.S. Cl.** **D8/70; D15/139**

[58] **Field of Search** D8/70; D15/127, D15/139; 30/307, 347, 355, 388, 389, 390, 365; 83/663, 676, 835

[56] **References Cited**

U.S. PATENT DOCUMENTS

D. 297,240	8/1988	Hatanaka	D15/139
D. 333,311	2/1993	Davis	D15/127

FOREIGN PATENT DOCUMENTS

56-0057	5/1981	Japan	.
2202401	8/1990	Japan	.

Primary Examiner—Antoine Duval Davis
Attorney, Agent, or Firm—Pearson & Pearson

[57] **CLAIM**

The ornamental design for a spiked feeding wheel for use in a board splitting apparatus, as shown and described.

DESCRIPTION

FIG. 1 front elevational view of a spiked feeding wheel for use in a board splitting apparatus showing my new design; FIG. 2 is a left side elevational view; FIG. 3 is a right side elevational view. FIG. 4 is a top plan view; FIG. 5 is a bottom plan view; FIG. 6 is a rear elevational view; FIG. 7 is a vertical cross-sectional view taken along line 7—7 of FIG. 1; FIG. 8 is a perspective view; FIG. 9 is a cross-sectional view taken along lines 9—9 of FIG. 1; FIG. 10 is a cross-sectional view taken along line 10—10 of FIG. 1; FIG. 11 is a second embodiment of a front elevational view of a spiked feeding wheel for use in a board splitting apparatus showing my new design; FIG. 12 is a left side elevational view; FIG. 13 is a right side elevational view. FIG. 14 is a top plan view; FIG. 15 is a bottom plan view; FIG. 16 is a rear elevational view; FIG. 17 is a vertical cross-sectional view taken along line 17—17 of FIG. 11; FIG. 18 is a perspective view; FIG. 19 is a cross-sectional view taken along lines 19—19 of FIG. 11; and, FIG. 20 is a cross-sectional view taken along line 20—20 of FIG. 11 thereof.

1 Claim, 14 Drawing Sheets

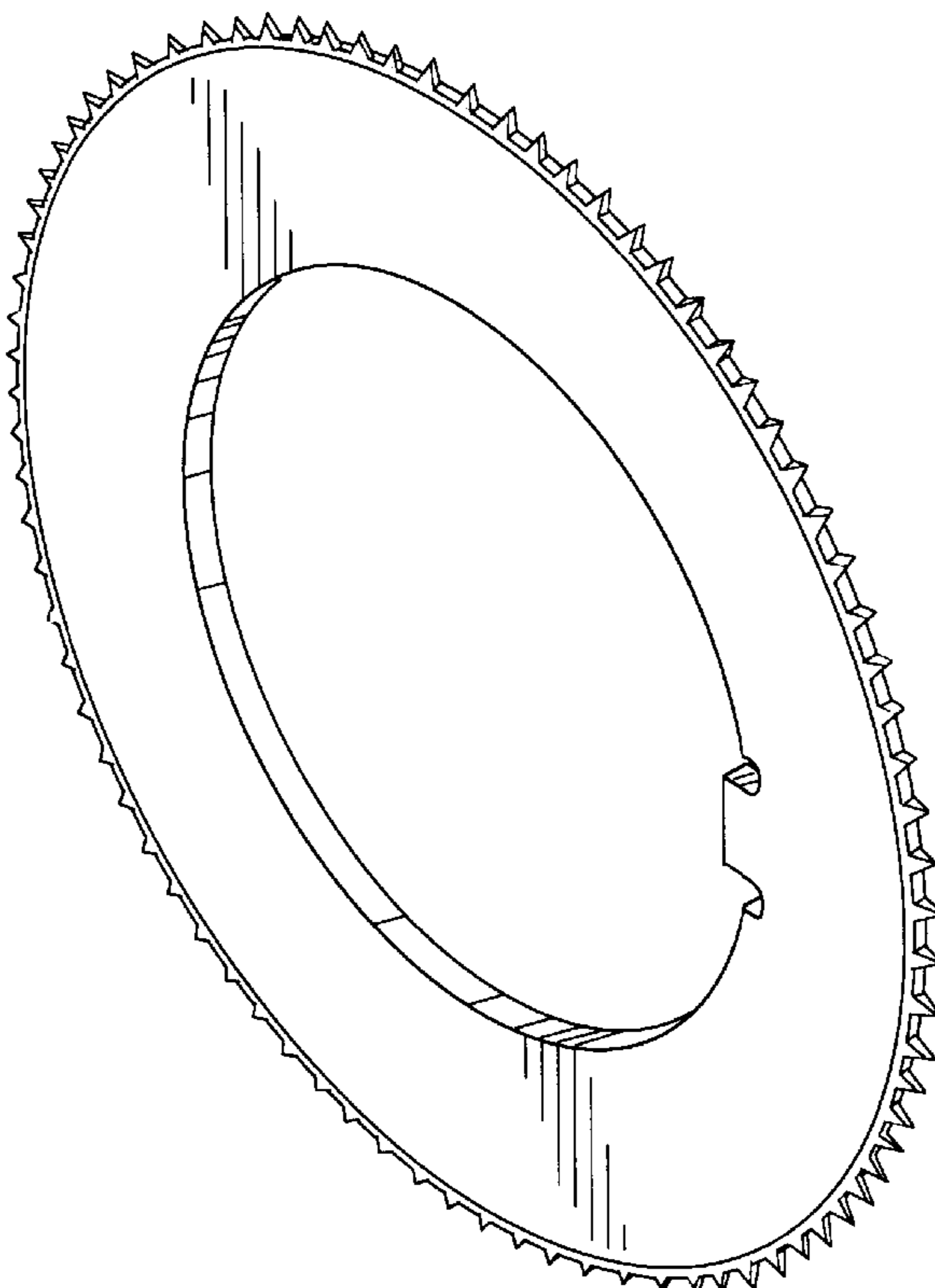

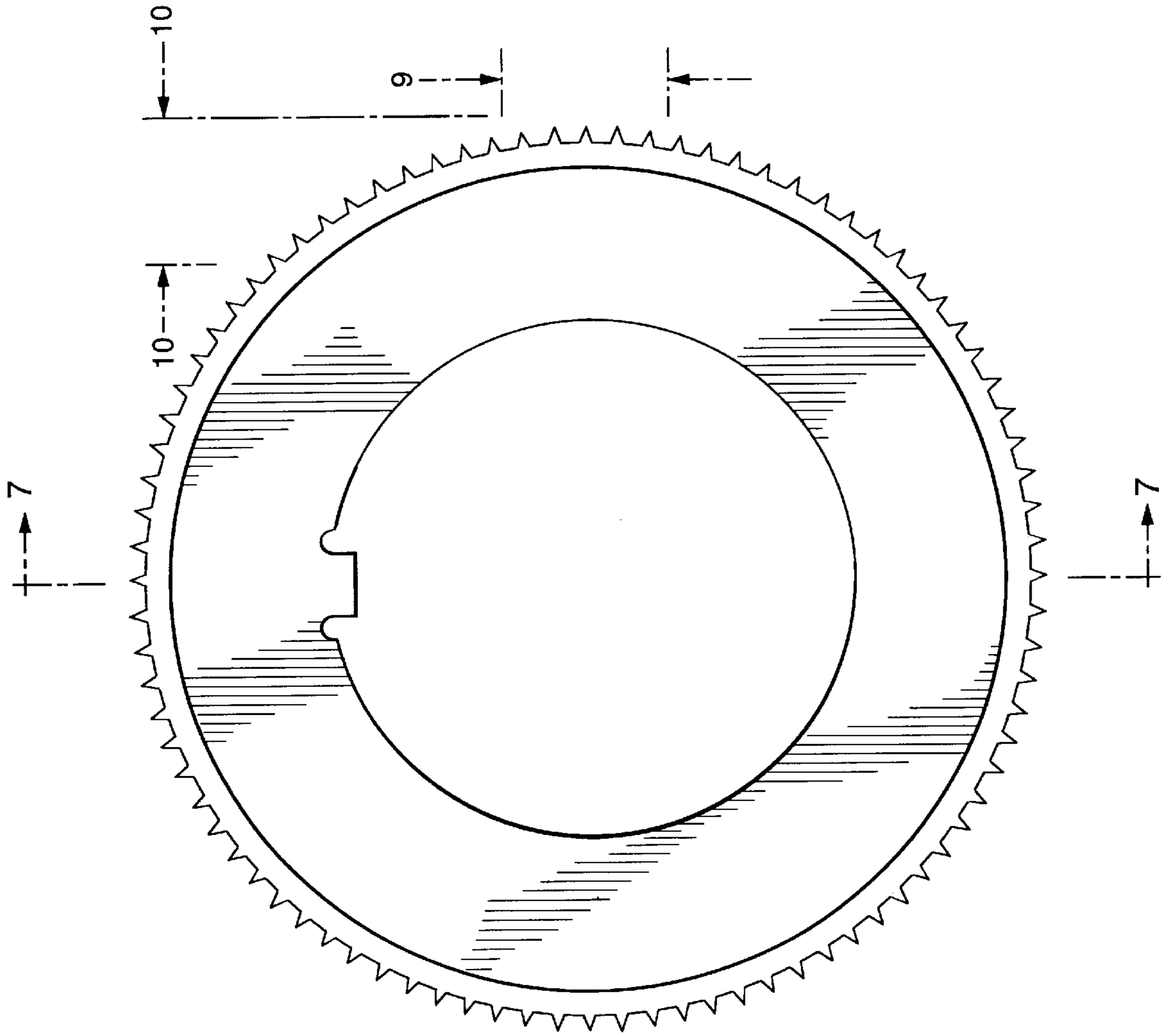

FIG. 1



FIG. 2



FIG. 3



FIG. 4



FIG. 5

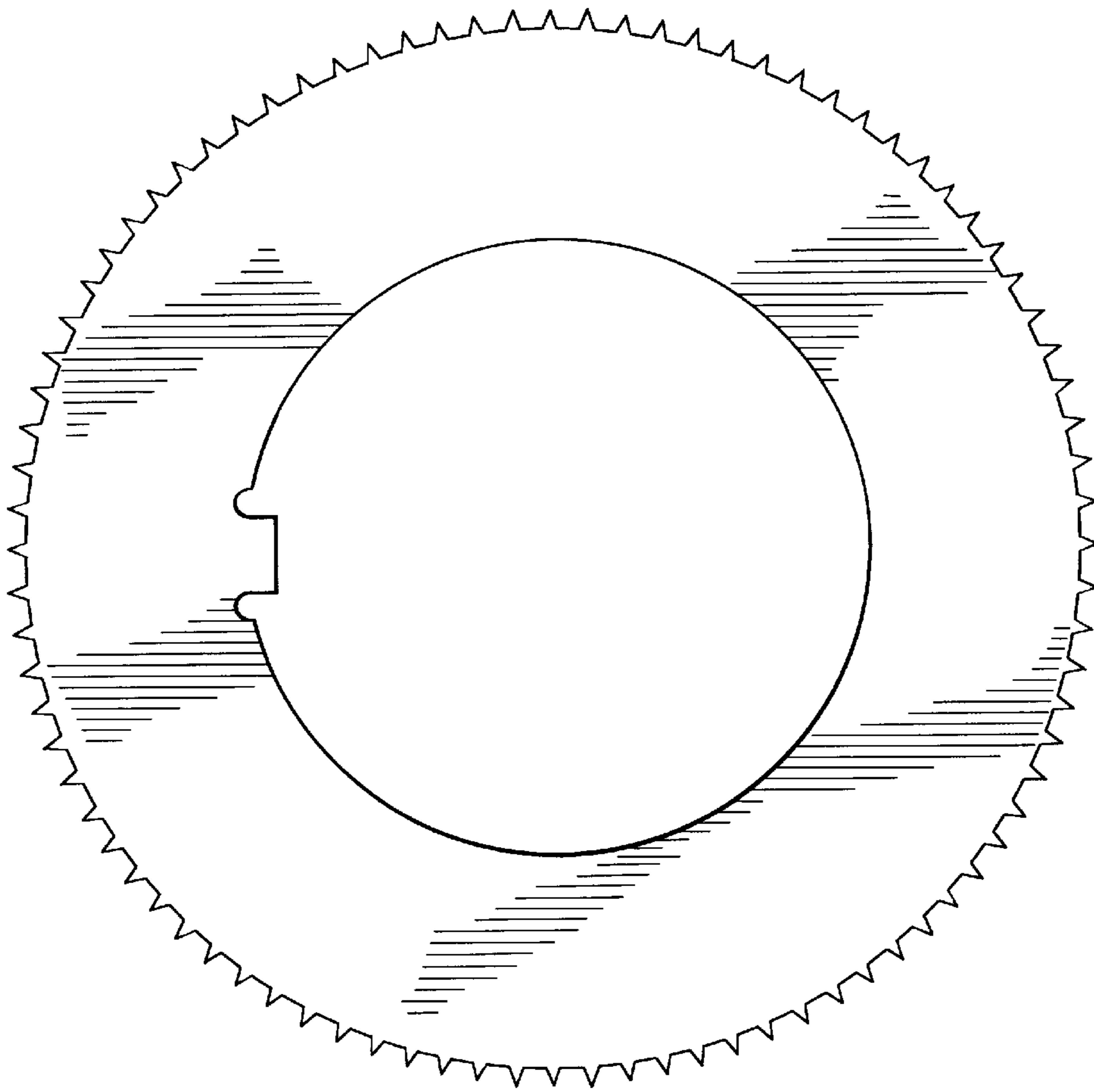

FIG. 6

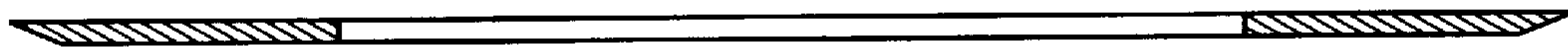

FIG. 7

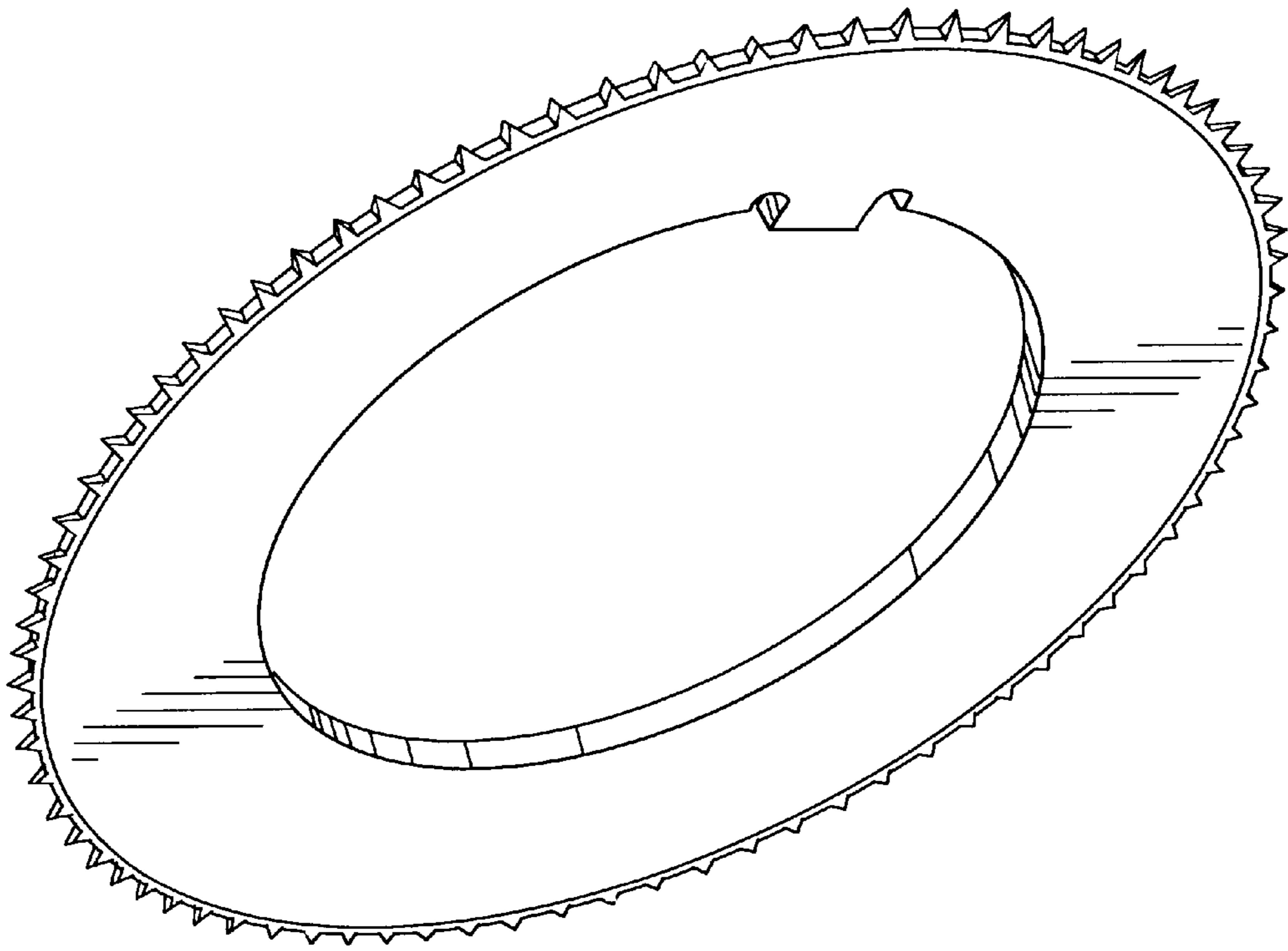

FIG. 8

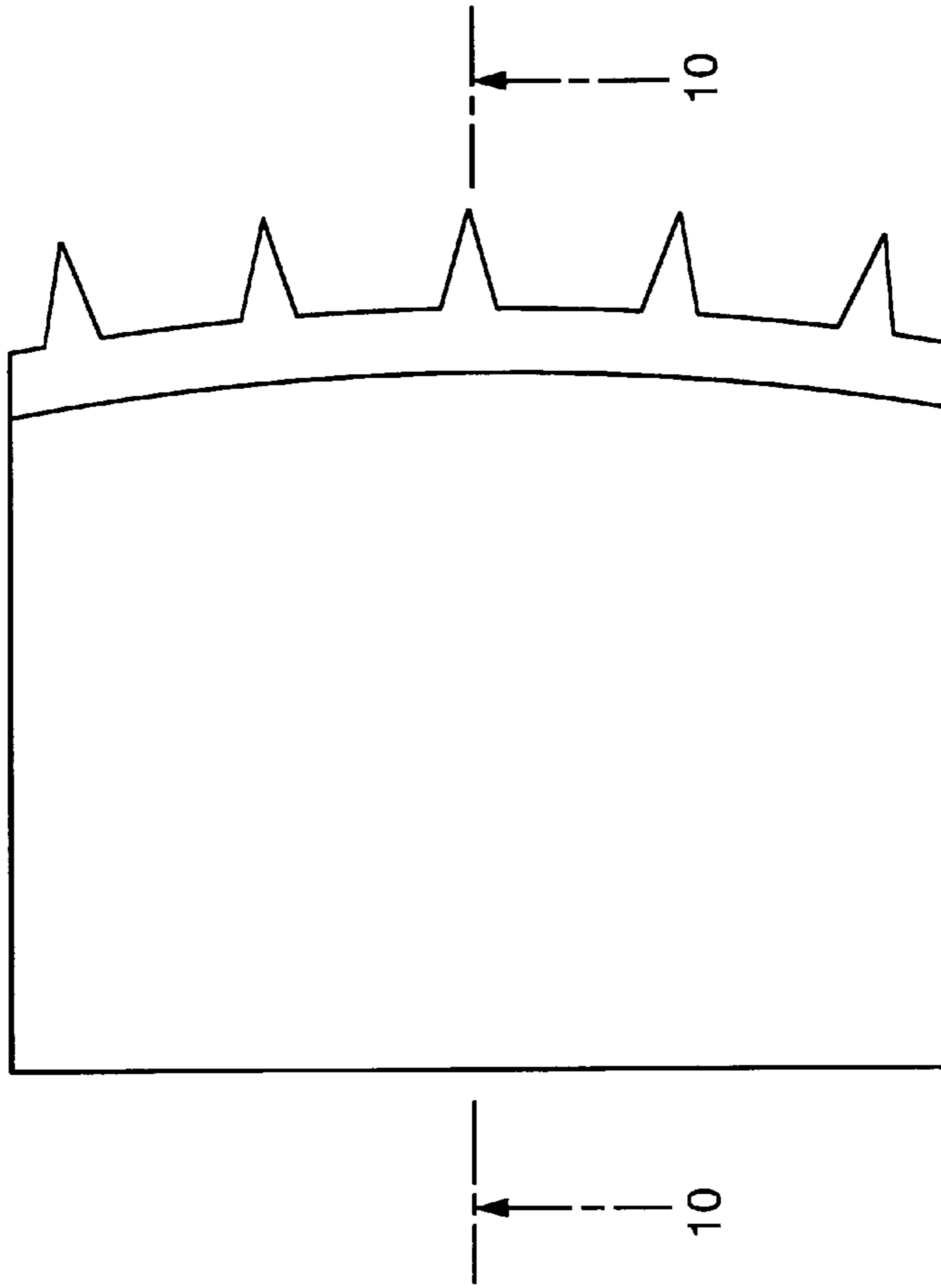

FIG. 9

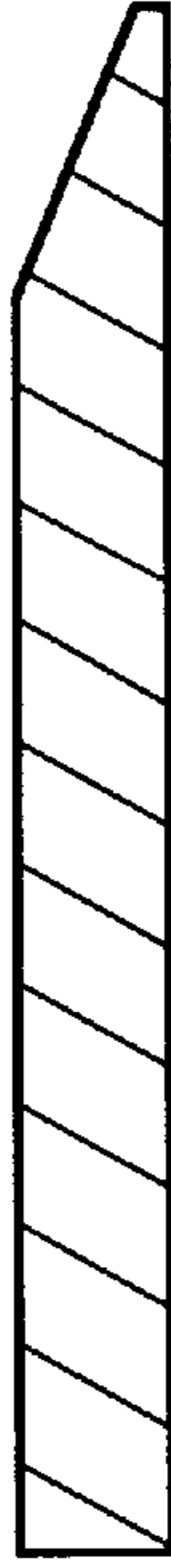

FIG. 10

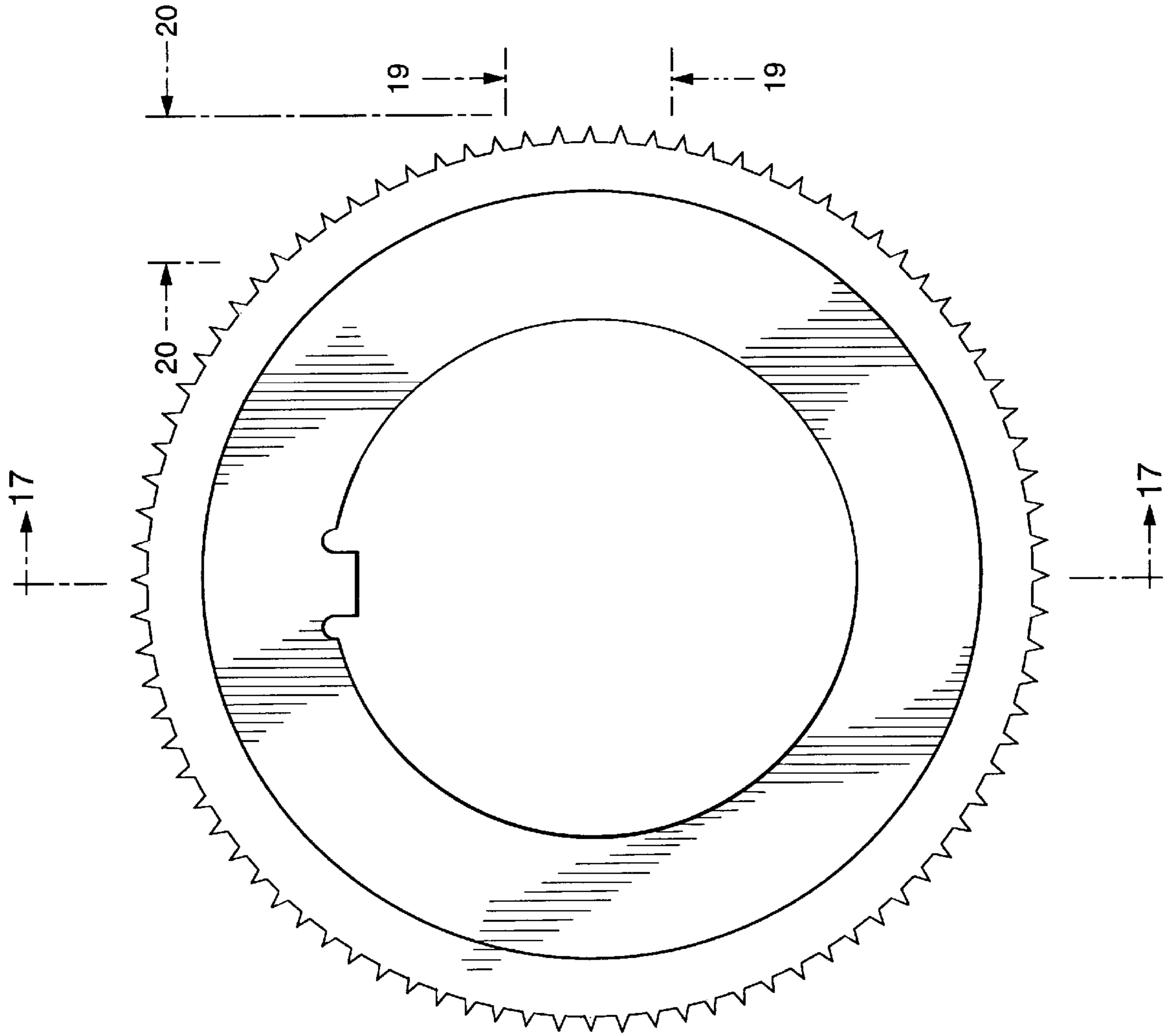

FIG. 11



FIG. 12



FIG. 13

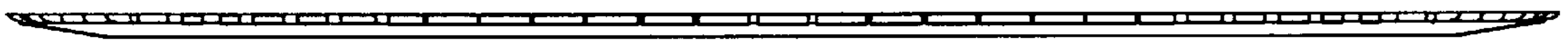

FIG. 14

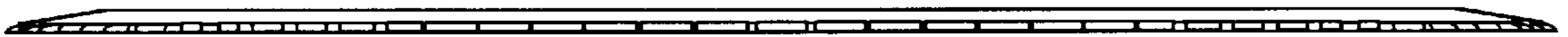

FIG. 15

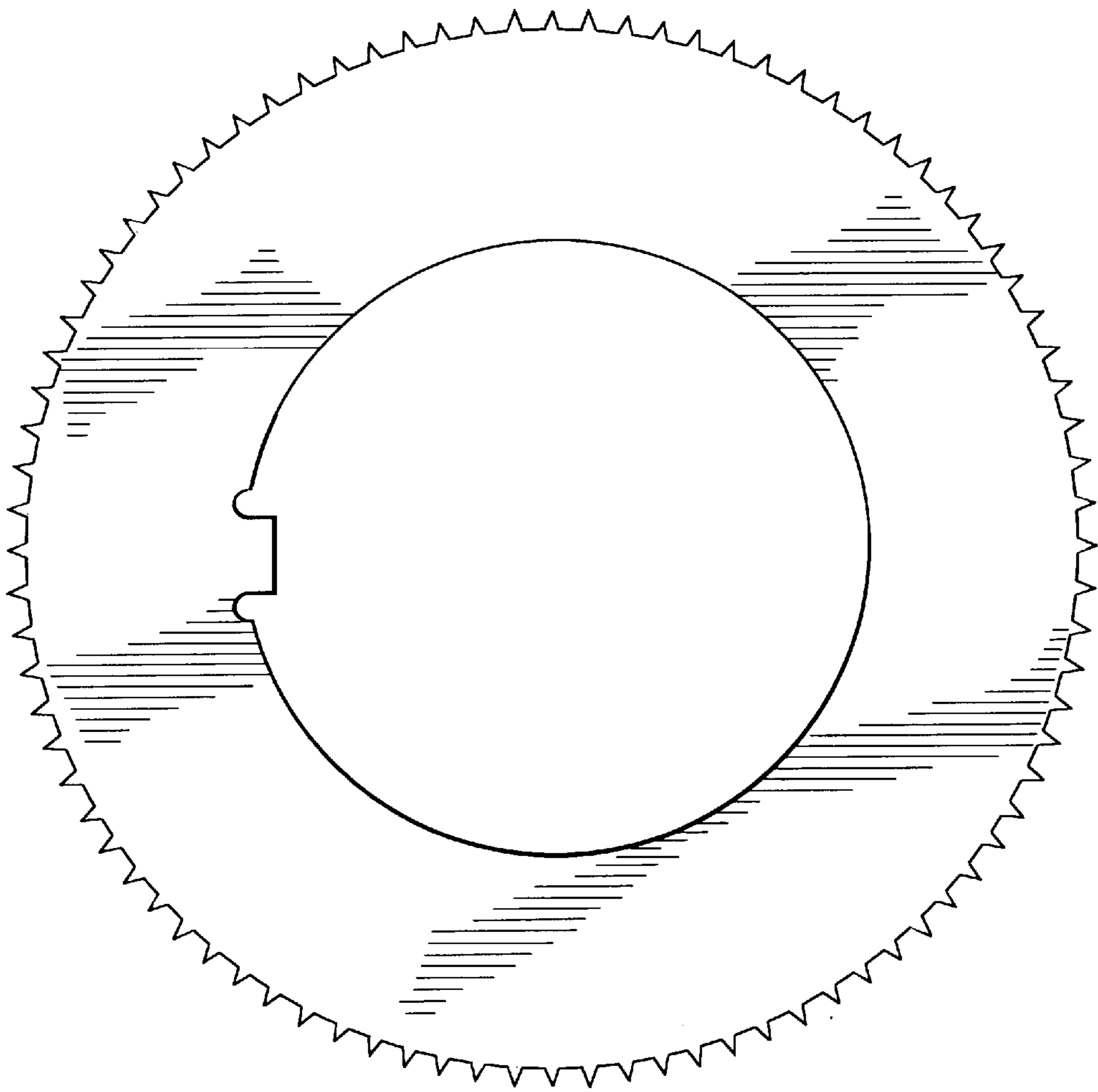

FIG. 16

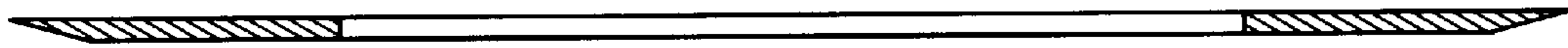

FIG. 17

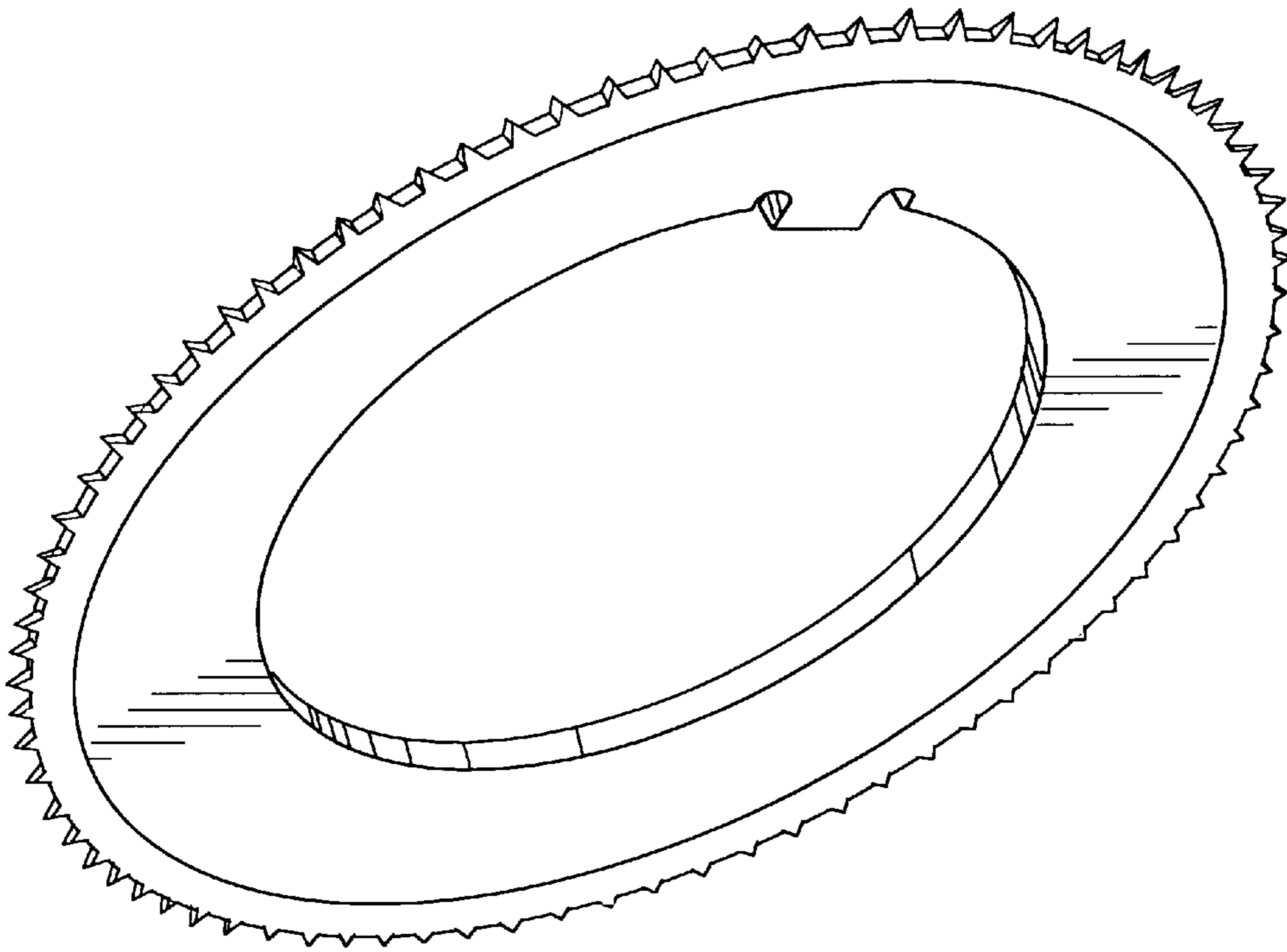

FIG. 18

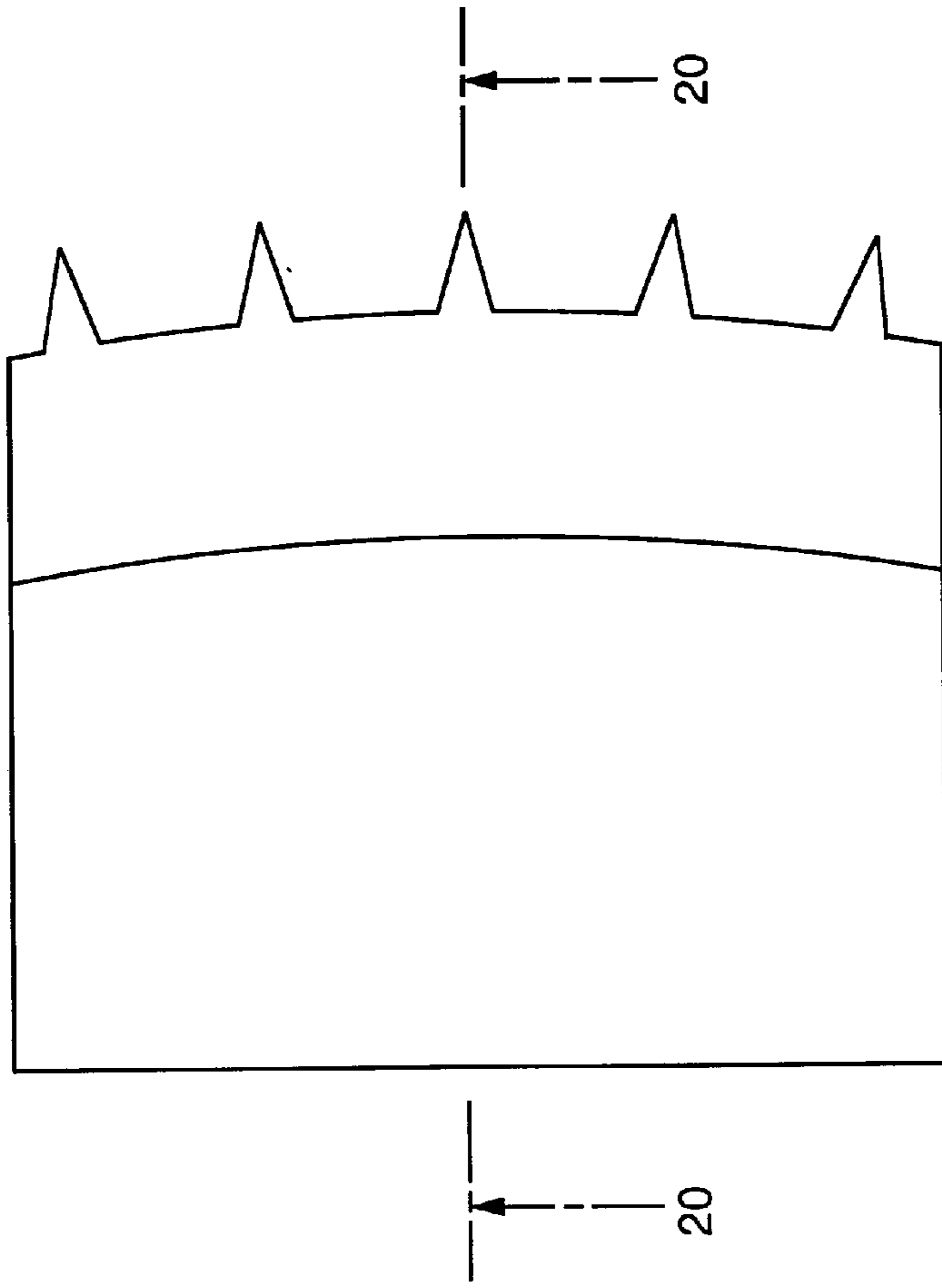

FIG. 19



FIG. 20