



US00D421631S

**United States Patent** [19]  
**Tsuda**

[11] **Patent Number: Des. 421,631**  
[45] **Date of Patent: \*\* Mar. 14, 2000**

[54] **VIDEO GAME MACHINE**

[75] Inventor: **Kimio Tsuda**, Tokyo, Japan

[73] Assignee: **Sega Enterprises, Ltd.**, Tokyo, Japan

[\*\*] Term: **14 Years**

[21] Appl. No.: **29/093,566**

[22] Filed: **Sep. 14, 1998**

[51] **LOC (6) Cl.** ..... **21-01**

[52] **U.S. Cl.** ..... **D21/329; D21/329**

[58] **Field of Search** ..... D21/324, 325,  
D21/326, 328, 329; 463/1, 29, 30, 35, 46,  
47, 51, 52; 273/355, 356, 357, 405

[56] **References Cited**

**U.S. PATENT DOCUMENTS**

D. 140,006	1/1945	Anderson	.....	D21/303
D. 253,293	10/1979	Takaichi et al.	.....	D21/326
D. 272,163	1/1984	Takizawa	.....	D21/324
D. 338,920	8/1993	Appel et al.	.....	D21/305
D. 358,616	5/1995	Chung-Po	.....	D21/325
D. 403,024	12/1998	Muraki et al.	.....	D21/326
3,568,332	3/1971	Koci et al.	.....	173/442 X
4,643,421	2/1987	Meyer et al.	.....	463/1
5,413,357	5/1995	Schulze et al.	.....	463/46 X
5,584,263	12/1996	Kelly et al.	.....	463/16

*Primary Examiner*—Prabhakar Deshmukh  
*Attorney, Agent, or Firm*—Dickstein Shapiro Morin & Oshinsky LLP

[57] **CLAIM**

The ornamental design for the video game machine, as shown as described.

**DESCRIPTION**

FIG. 1 is a front, top and right side perspective view showing one embodiment of my new design for a video game machine;

FIG. 2 is a rear, top and left side perspective view of the video game machine of FIG. 1;

FIG. 3 is a front elevational view of the video game machine of FIG. 1;

FIG. 4 is a rear elevational view of the video game machine of FIG. 1;

FIG. 5 is a top plan view of the video game machine of FIG. 1;

FIG. 6 is a bottom plan view of the video game machine of FIG. 1;

FIG. 7 is a right side elevational view of the video game machine of FIG. 1;

FIG. 8 is a left side elevational view of the video game machine of FIG. 1;

FIG. 9 is a front, top and right side perspective view showing another embodiment of my new design for a video game machine;

FIG. 10 is a rear, top and left side perspective view of the video game machine of FIG. 9;

FIG. 11 is a front elevational view of the video game machine of FIG. 9;

FIG. 12 is a rear elevational view of the video game machine of FIG. 9;

FIG. 13 is a top plan view of the video game machine of FIG. 9;

FIG. 14 is a bottom plan view of the video game machine of FIG. 9;

FIG. 15 is a right side elevational view of the video game machine of FIG. 9; and,

FIG. 16 is a left side elevational view of the video game machine of FIG. 9.

**1 Claim, 14 Drawing Sheets**

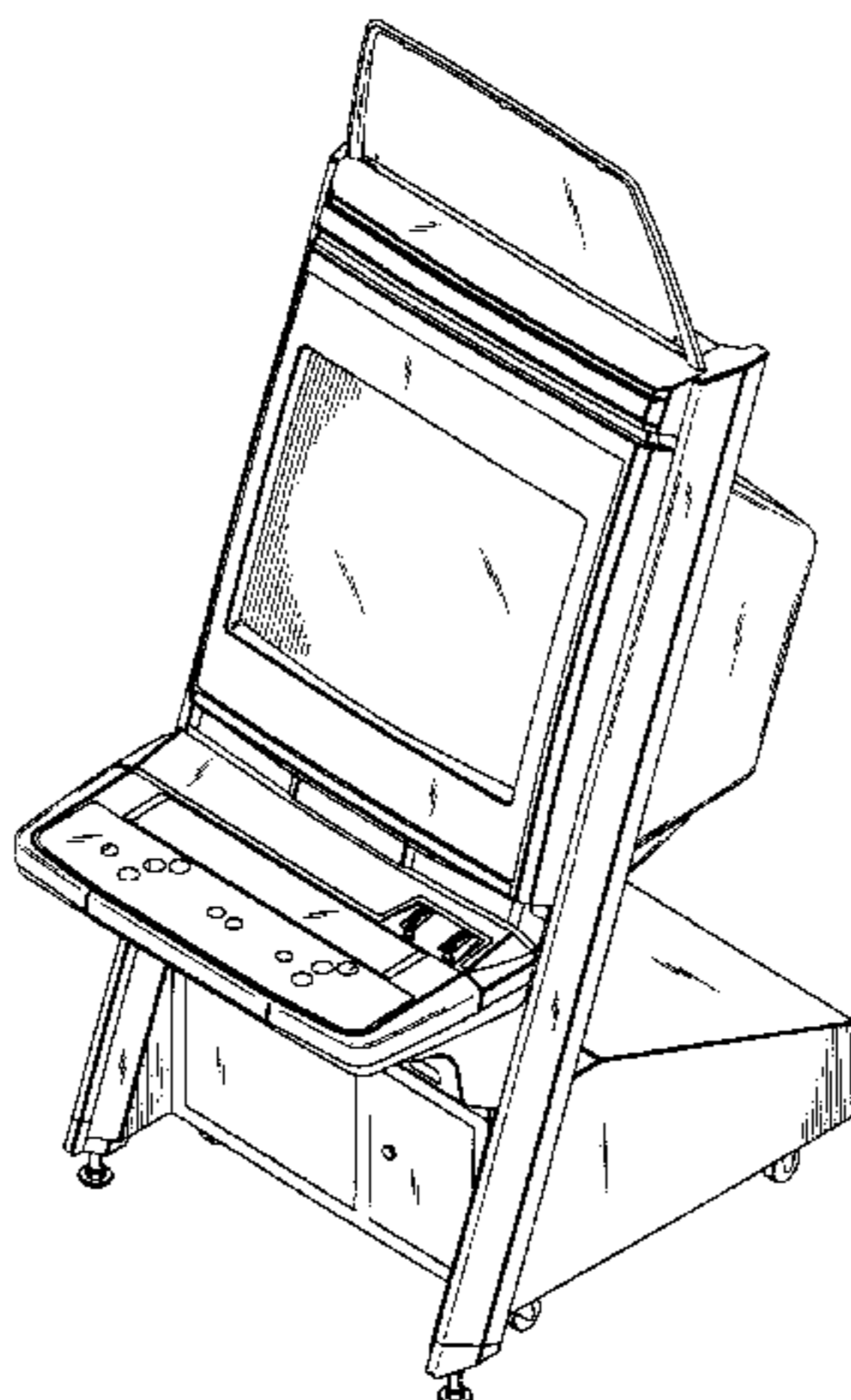

FIG. 1

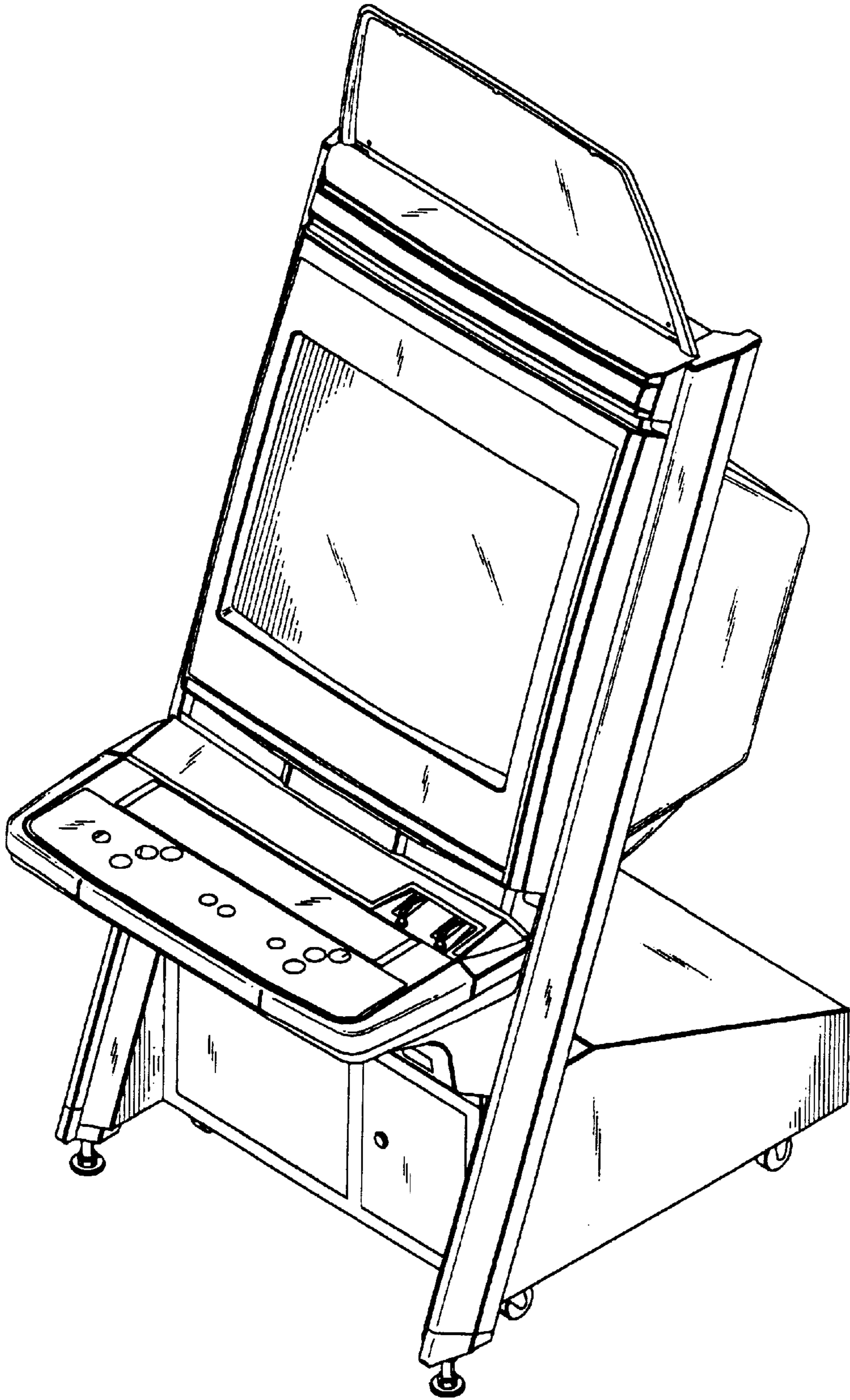

FIG. 2

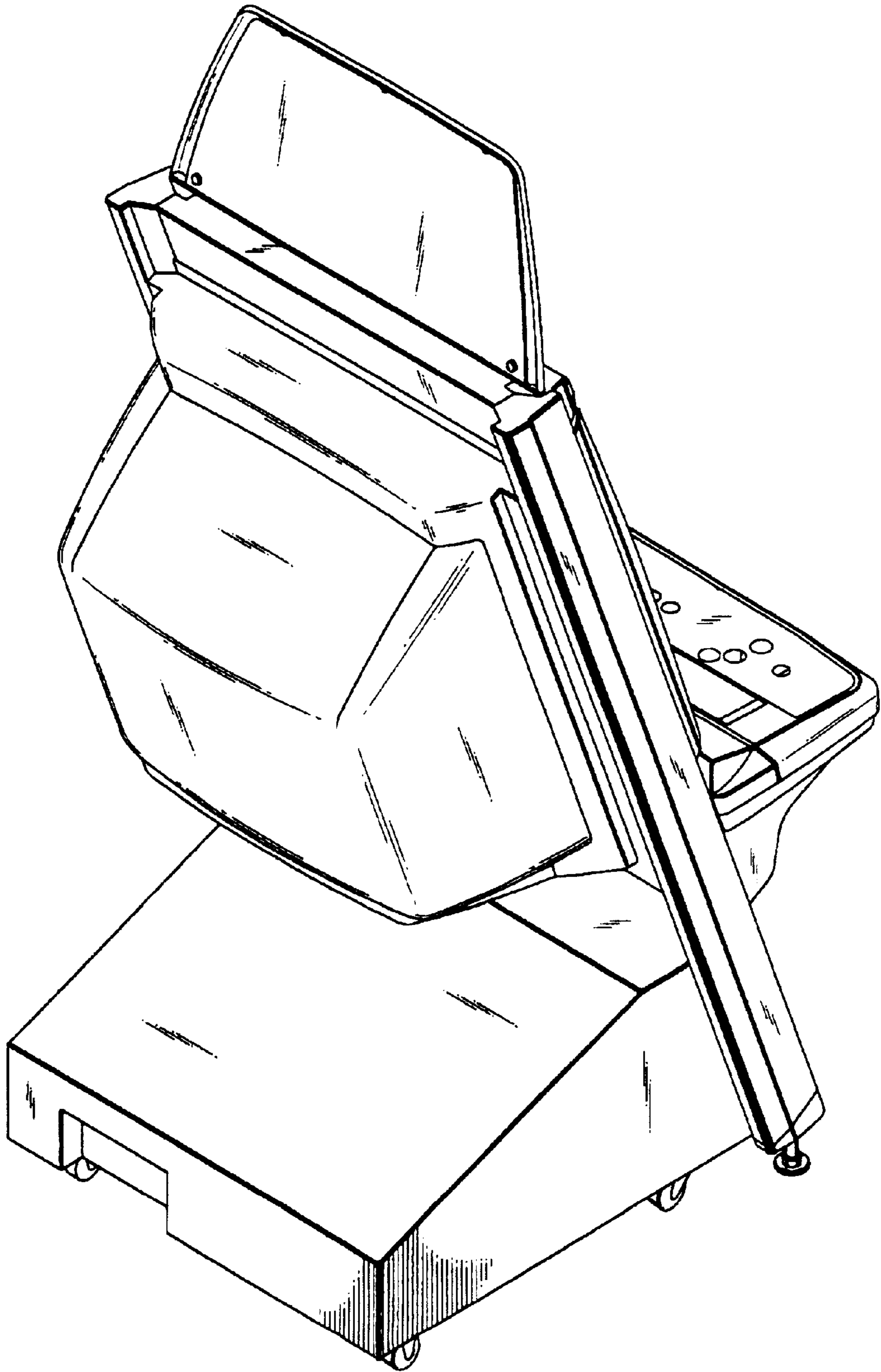

FIG. 3

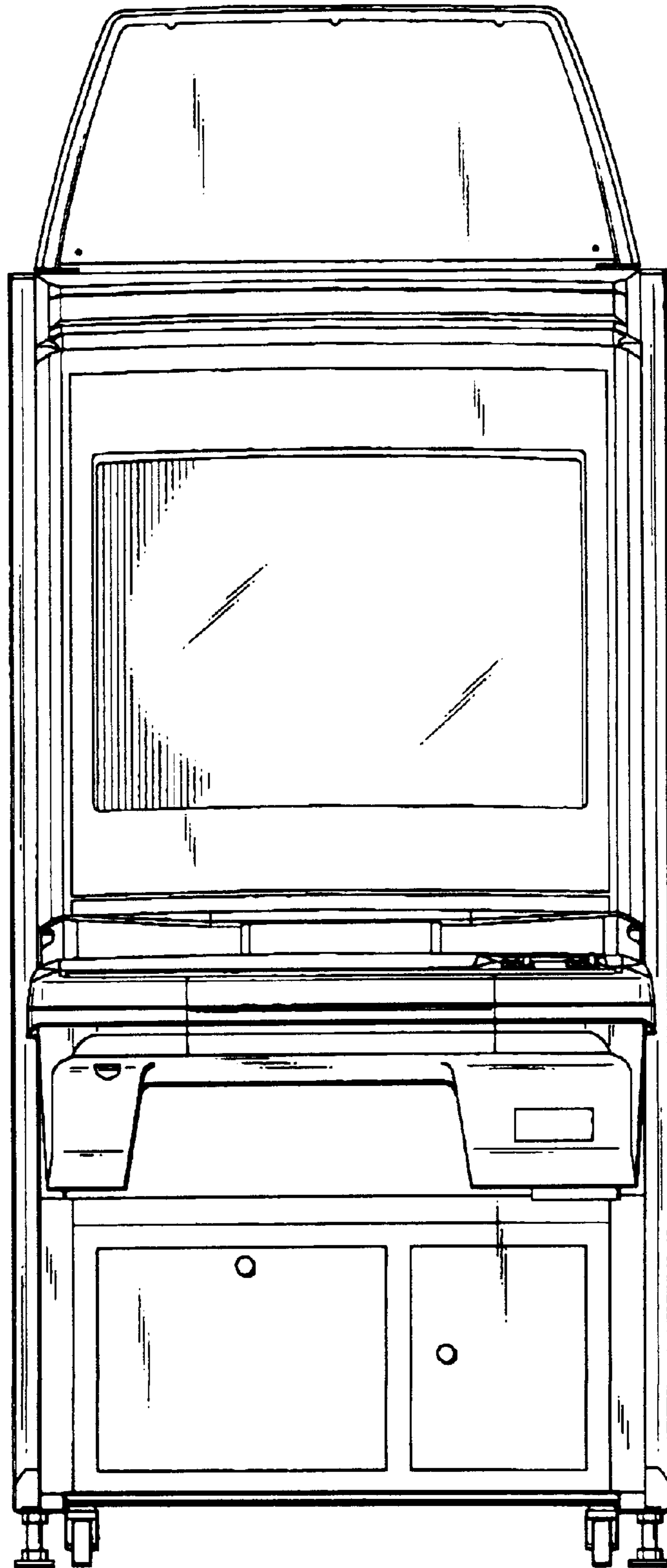



FIG. 4

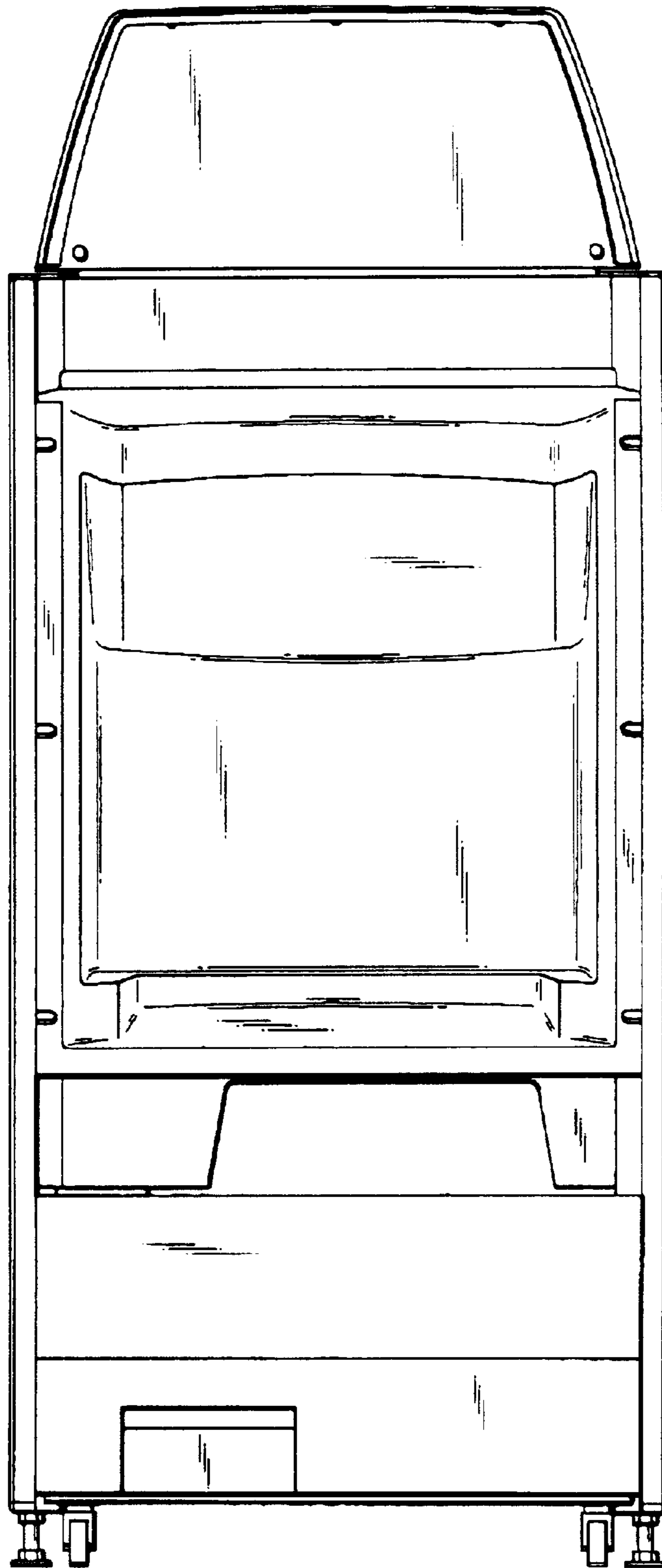

FIG. 6

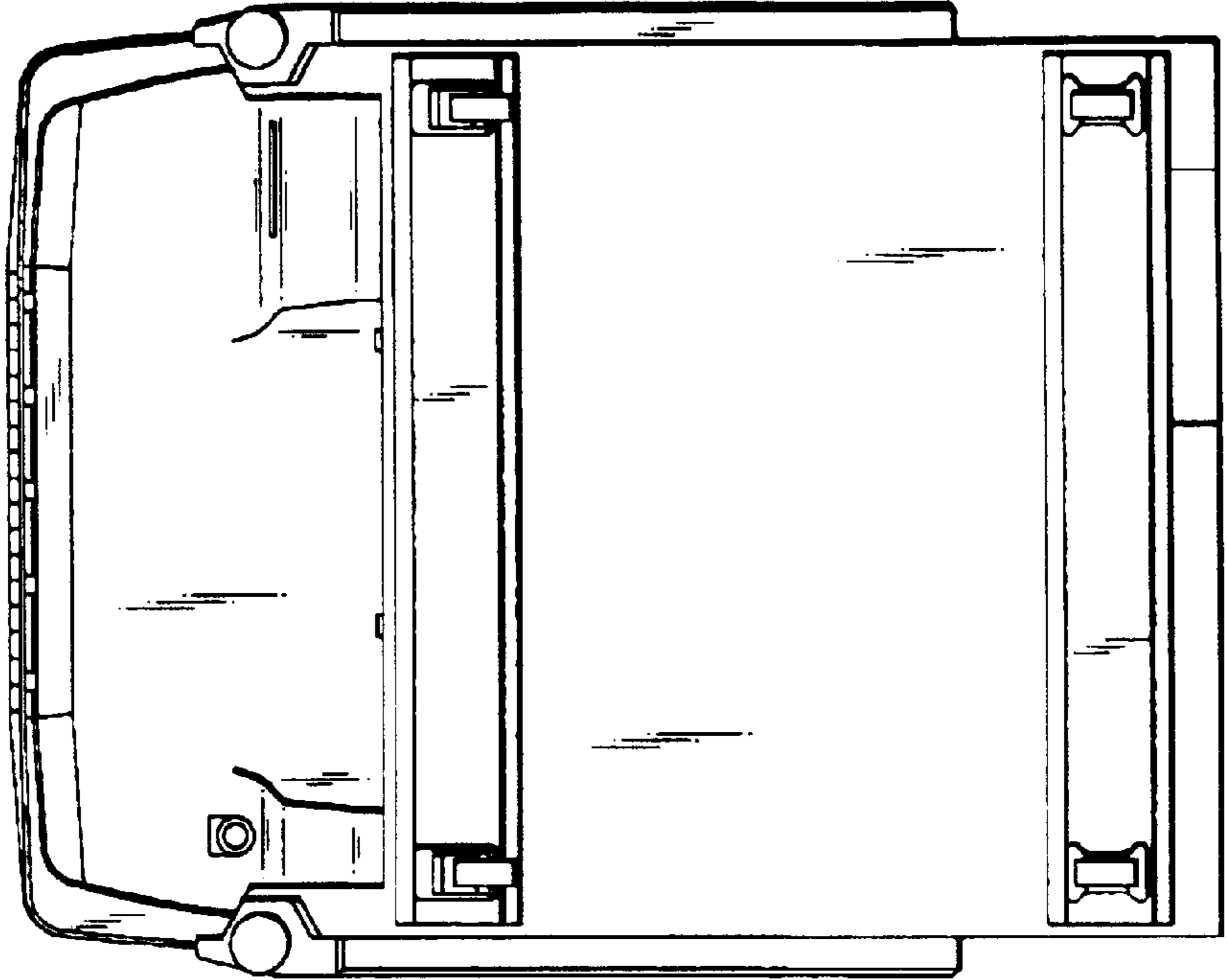

FIG. 5

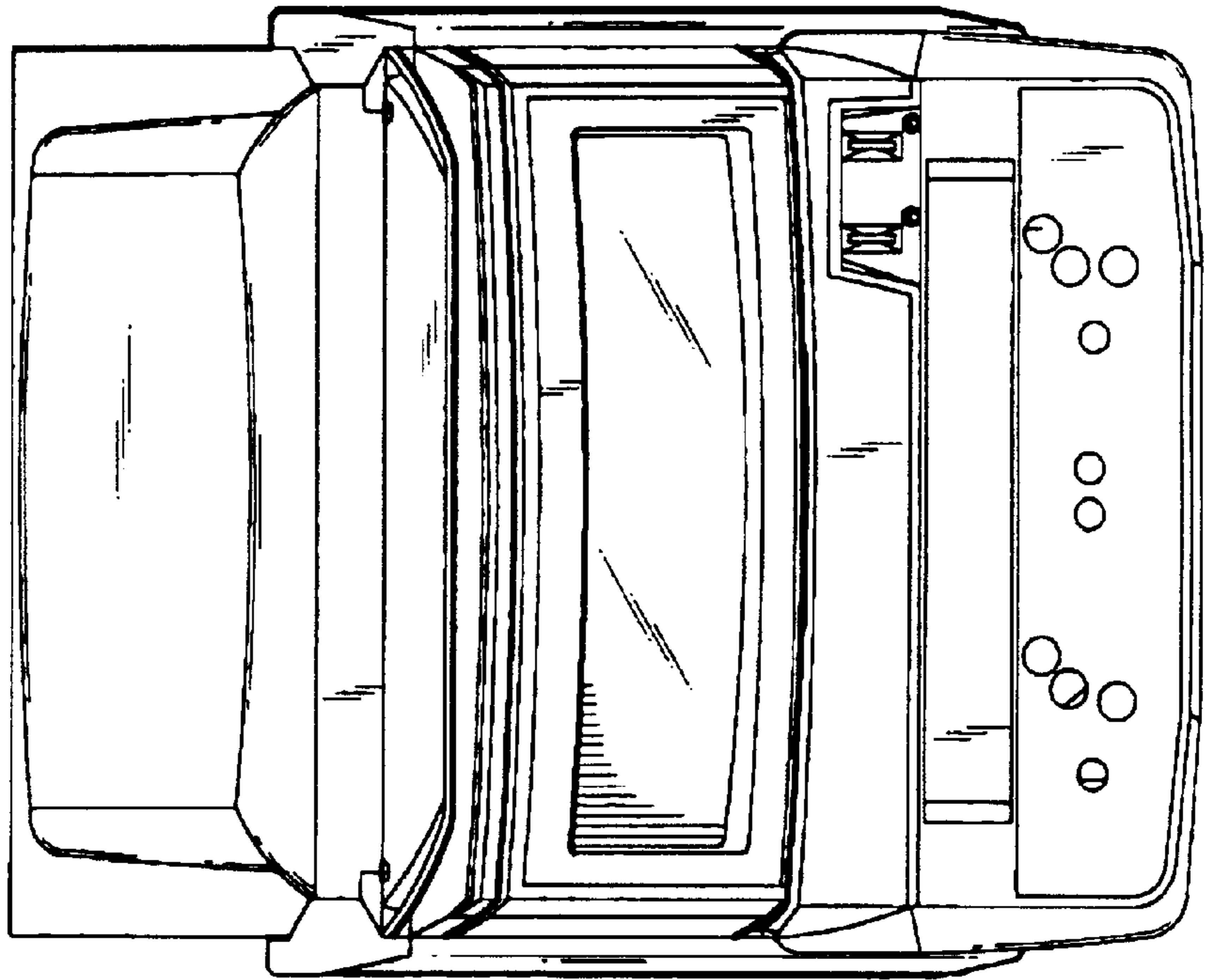

FIG. 7

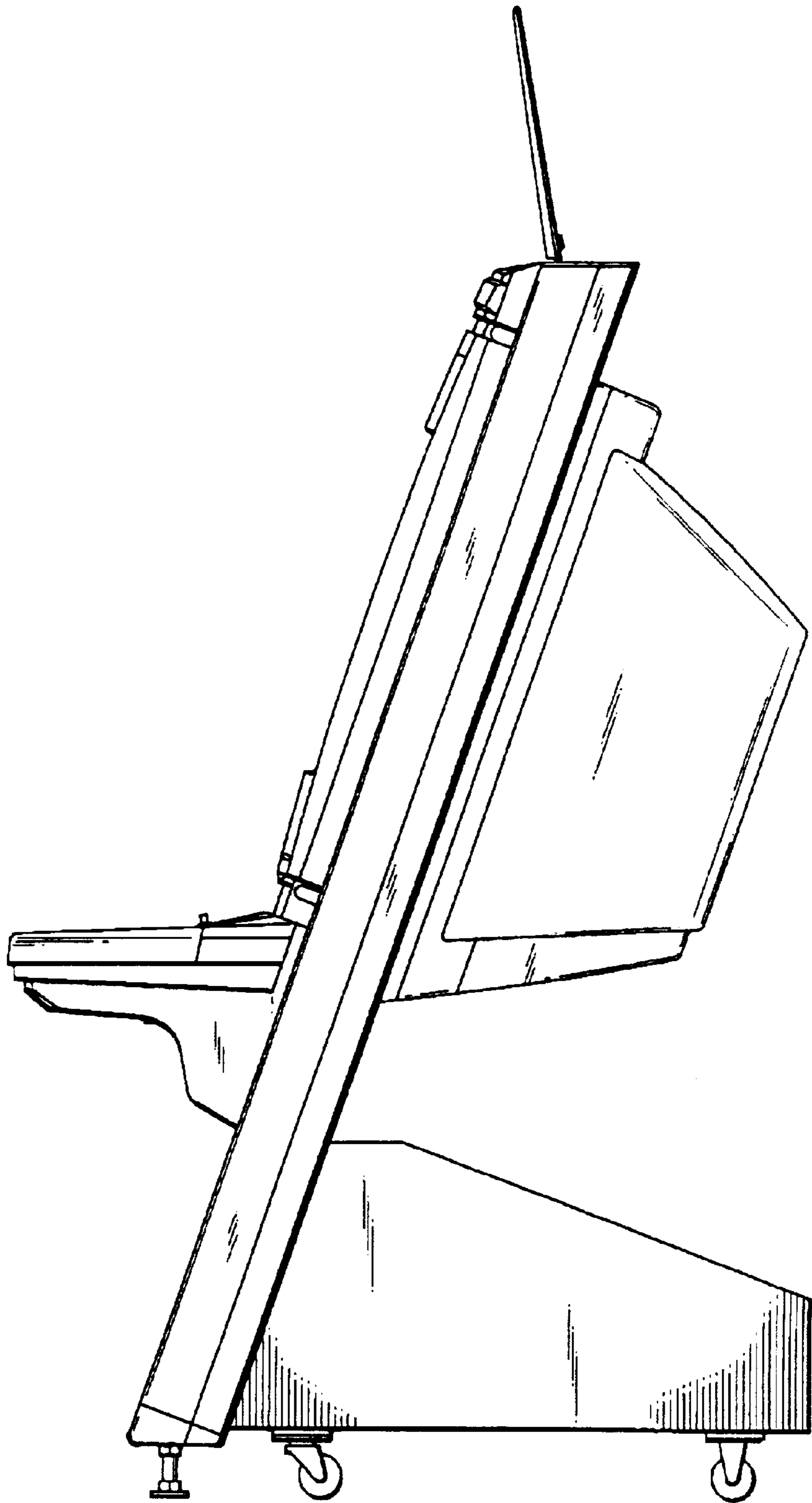

FIG. 8

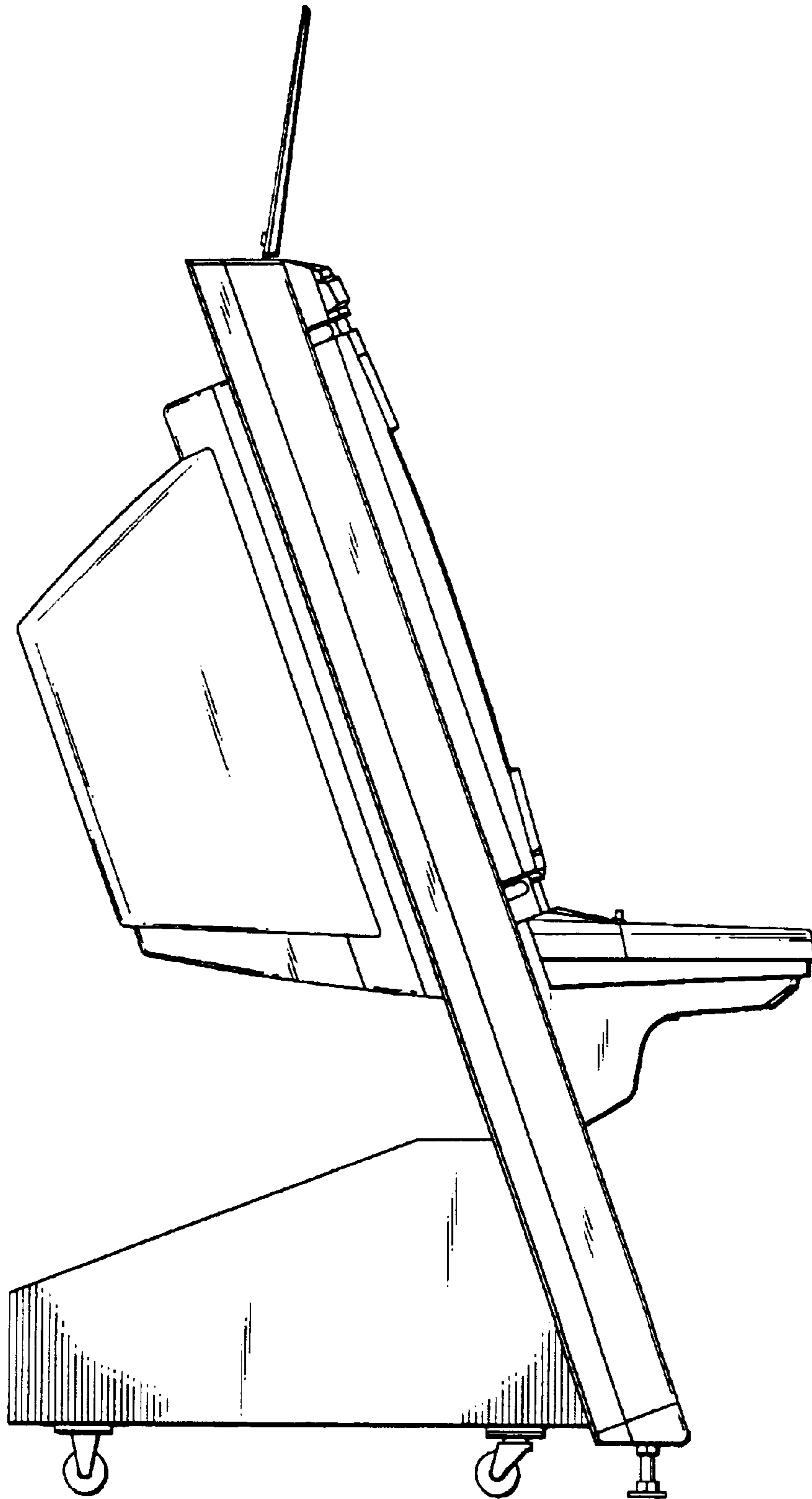



FIG. 9

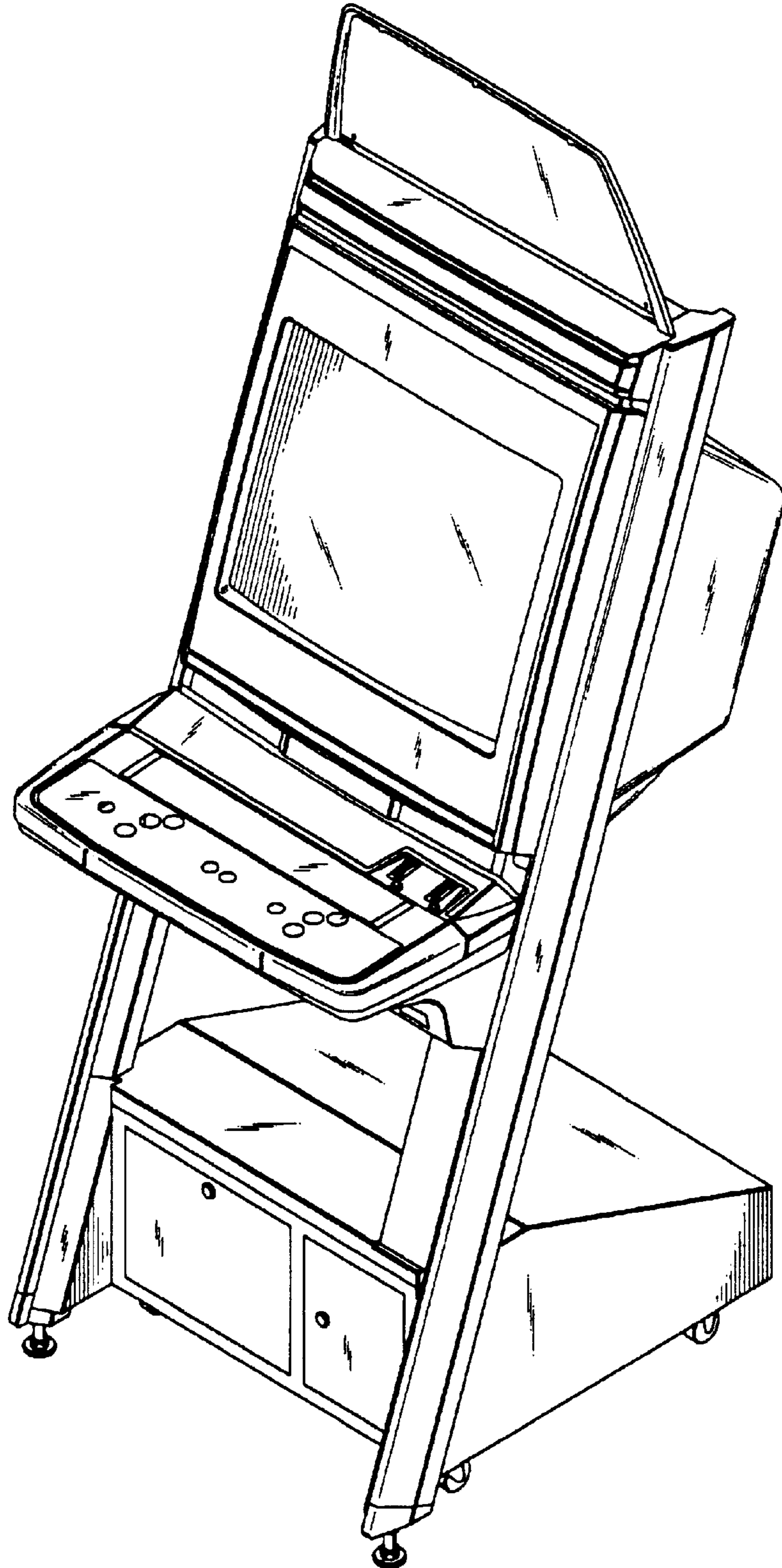

FIG. 10

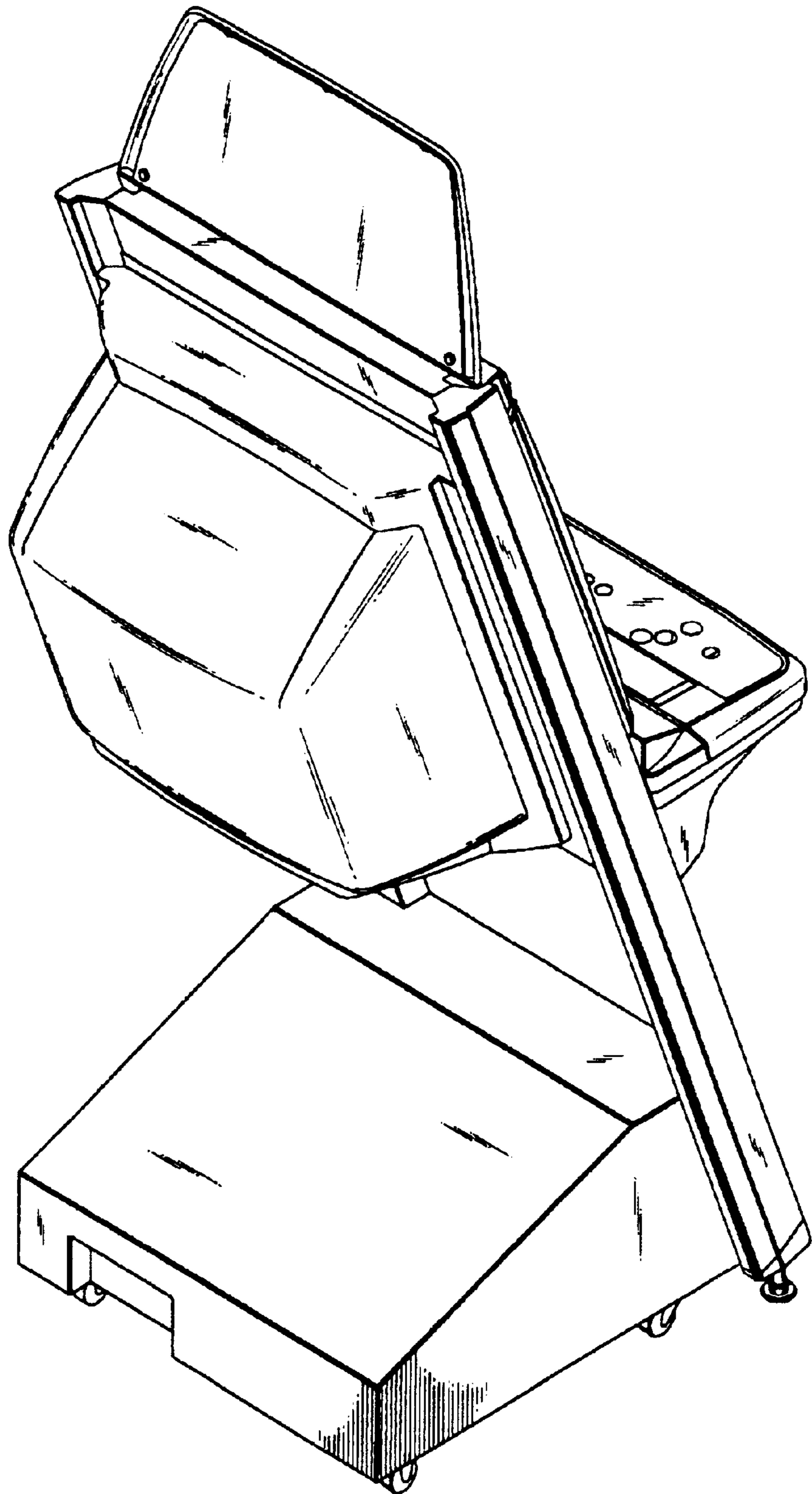

FIG. 11

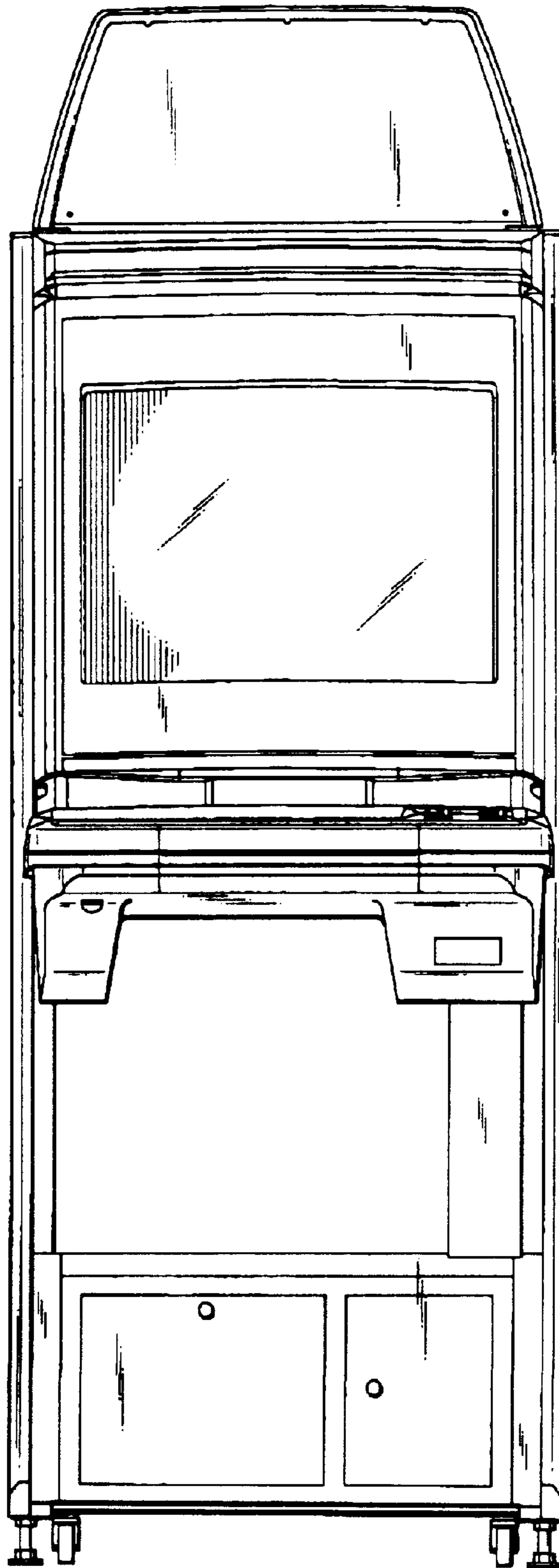

FIG. 12

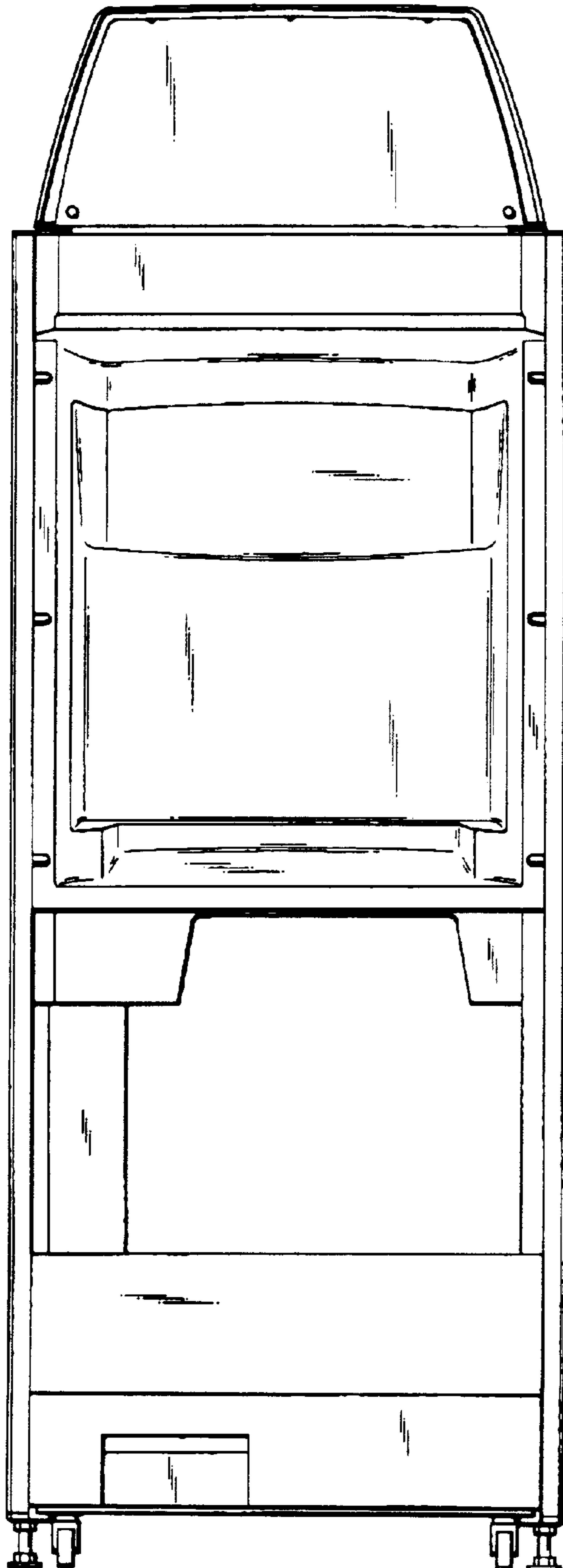

FIG. 14

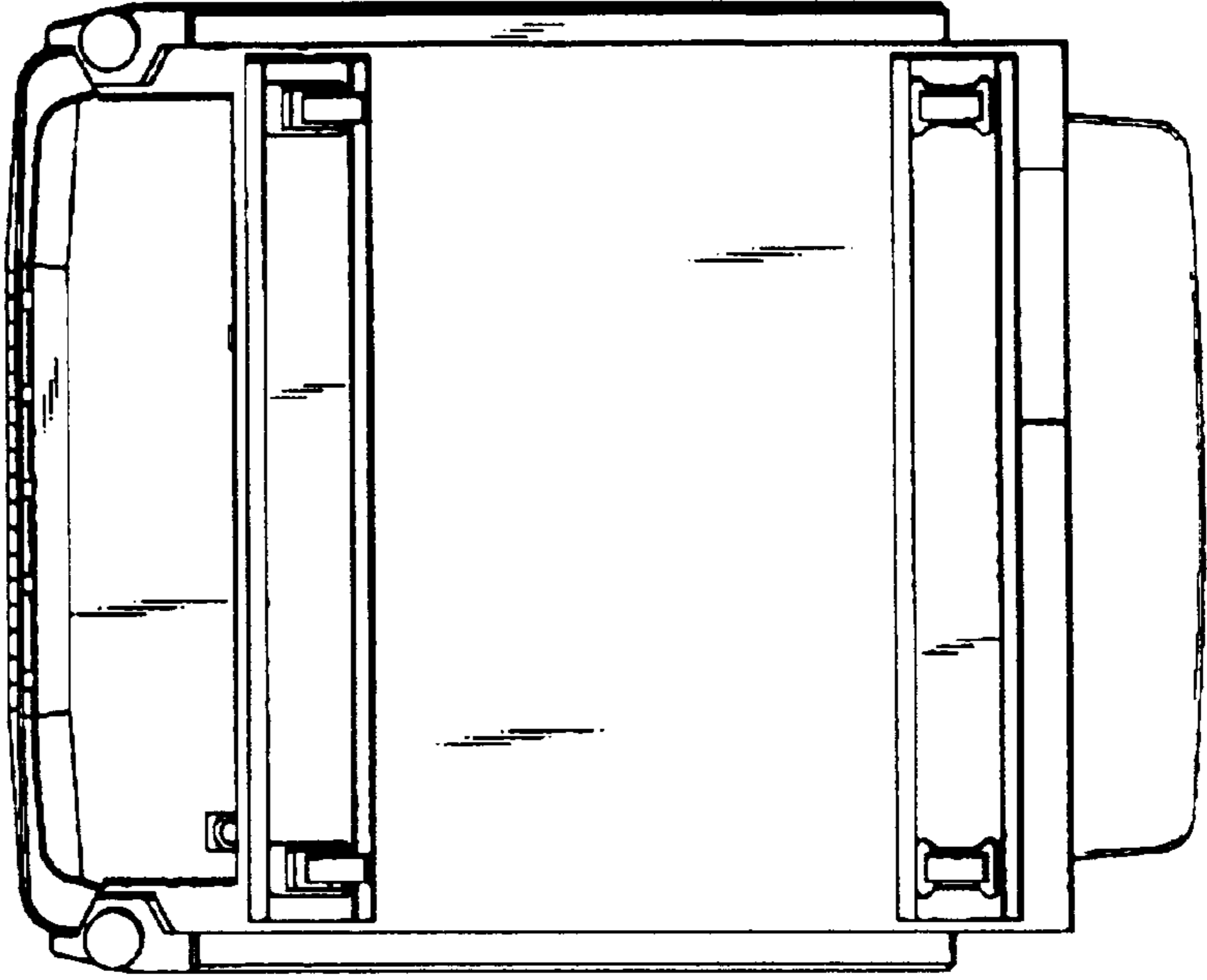

FIG. 13

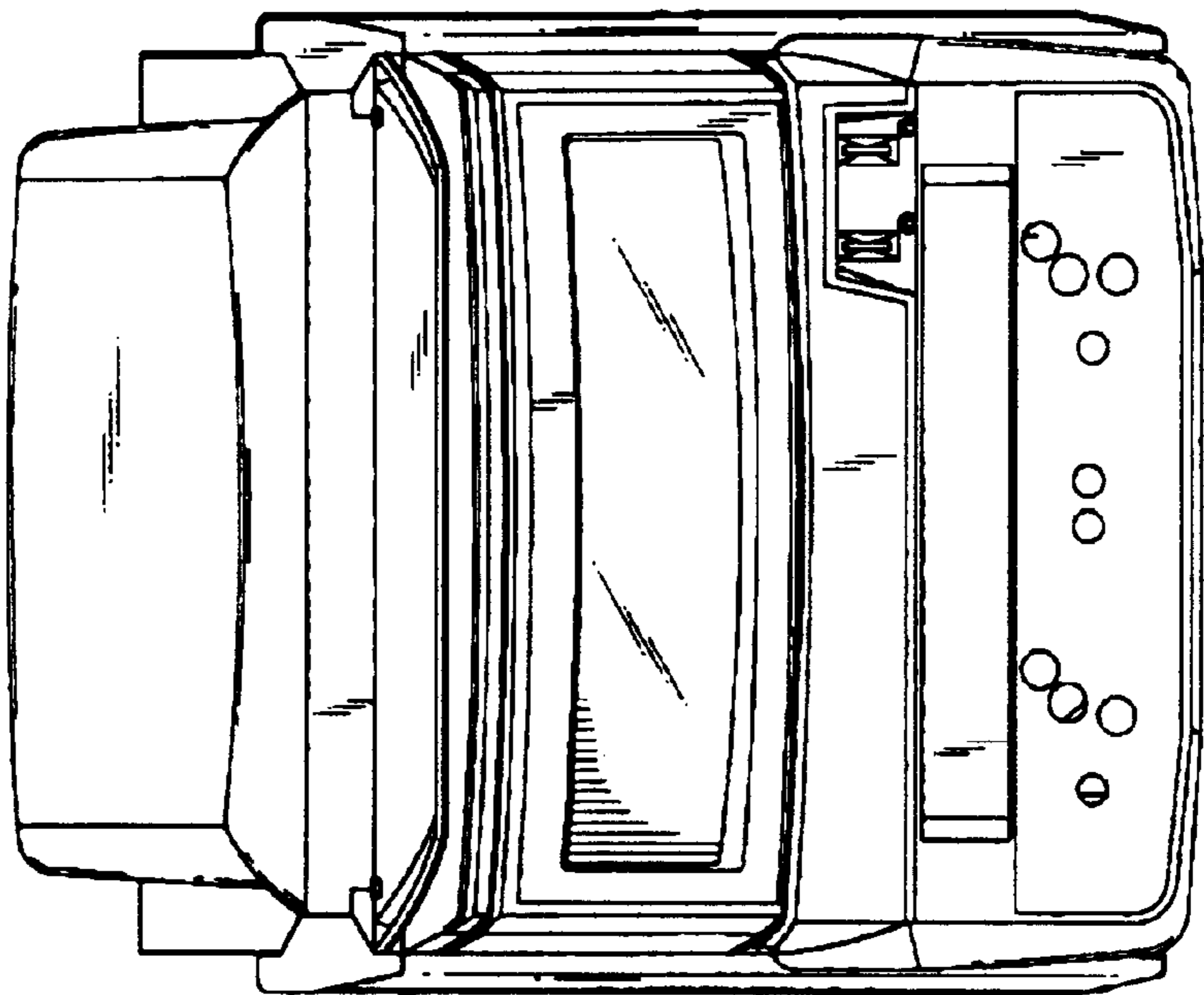



FIG. 15

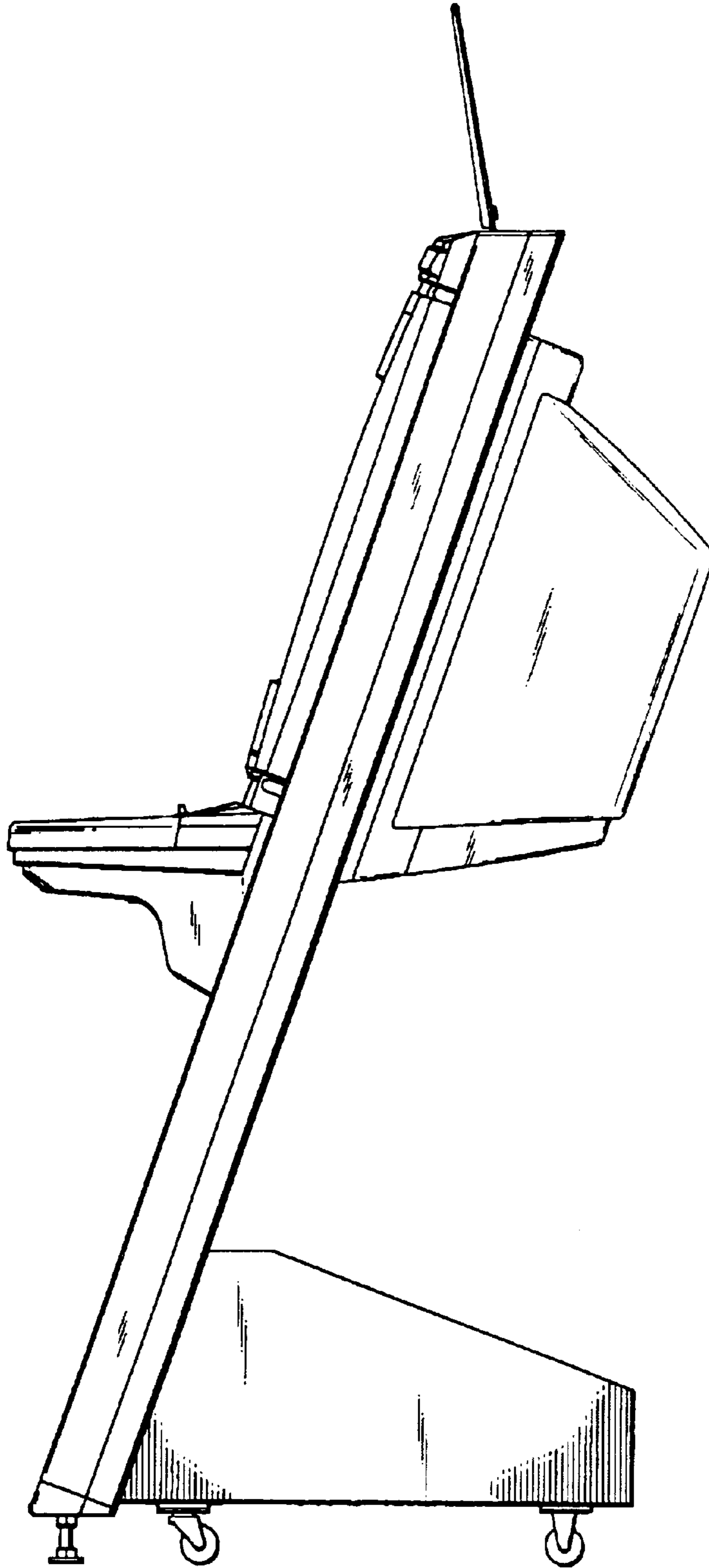

FIG. 16

