



US00D421588S

United States Patent [19]
Kitamura

[11] **Patent Number: Des. 421,588**
[45] **Date of Patent: ** Mar. 14, 2000**

[54] **REAR PORTION OF A MOTOR VEHICLE**

DESCRIPTION

[75] Inventor: **Eiji Kitamura**, Hiroshima, Japan

[73] Assignee: **Mazda Motor Corporation**,
Hiroshima-ken, Japan

[**] Term: **14 Years**

[21] Appl. No.: **29/100,543**

[22] Filed: **Feb. 12, 1999**

[51] **LOC (6) Cl.** **12-16**

[52] **U.S. Cl.** **D12/196**

[58] **Field of Search** D12/196, 90-92;
296/185

[56] **References Cited**

U.S. PATENT DOCUMENTS

- D. 373,342 9/1996 Moore D12/196
- D. 395,619 6/1998 Cho D12/91
- 5,449,213 9/1995 Kiley et al. 296/56

OTHER PUBLICATIONS

Bullentin des Dessins et Modeles Internationaus (International Designs Bullentin) Apr. 1994, Depot No. DM/030 569 dated Apr. 13, 1994 in the name of Fiat Auto S.P.A., pp. 4529-30 and 4539.

Primary Examiner—Melody N. Brown

Attorney, Agent, or Firm—Hugh A. Abrams; Sidley & Austin

[57] **CLAIM**

The ornamental design for a rear portion of a motor vehicle, as shown and described.

FIG. 1 is a perspective view of a rear portion of a motor vehicle showing a first embodiment of my new design; FIG. 2 is a front elevational view of the rear portion of the motor vehicle shown in FIG. 1; FIG. 3 is a rear elevational view of the rear portion of the motor vehicle shown in FIG. 1; FIG. 4 is a top plan view of the rear portion of the motor vehicle shown in FIG. 1; FIG. 5 is a left side elevational view of the rear portion of the motor vehicle shown in FIG. 1; FIG. 6 is a right side elevational view of the rear portion of the motor vehicle shown in FIG. 1; FIG. 7 is a perspective view of a rear portion of a motor vehicle showing a second embodiment of my new design; FIG. 8 is a front elevational view of the rear portion of the motor vehicle shown in FIG. 7; FIG. 9 is a rear elevational view of the rear portion of the motor vehicle shown in FIG. 7; FIG. 10 is a top plan view of the rear portion of the motor vehicle shown in FIG. 7; FIG. 11 is a left side elevational view of the rear portion of the motor vehicle shown in FIG. 7; FIG. 12 is a right side elevational view of the rear portion of the motor vehicle shown in FIG. 7; FIG. 13 is a perspective view of a rear portion of a motor vehicle showing a third embodiment of my new design; FIG. 14 is a front elevational view of the rear portion of the motor vehicle shown in FIG. 13; FIG. 15 is a rear elevational view of the rear portion of the motor vehicle shown in FIG. 13; FIG. 16 is a top plan view of the rear portion of the motor vehicle shown in FIG. 13; FIG. 17 is a left side elevational view of the rear portion of the motor vehicle shown in FIG. 13; and, FIG. 18 is a right side elevational view of the rear portion of the motor vehicle shown in FIG. 13.

The portion of the motor vehicle shown in broken lines is for illustrative purpose only and forms no parts of the claimed design.

1 Claim, 15 Drawing Sheets

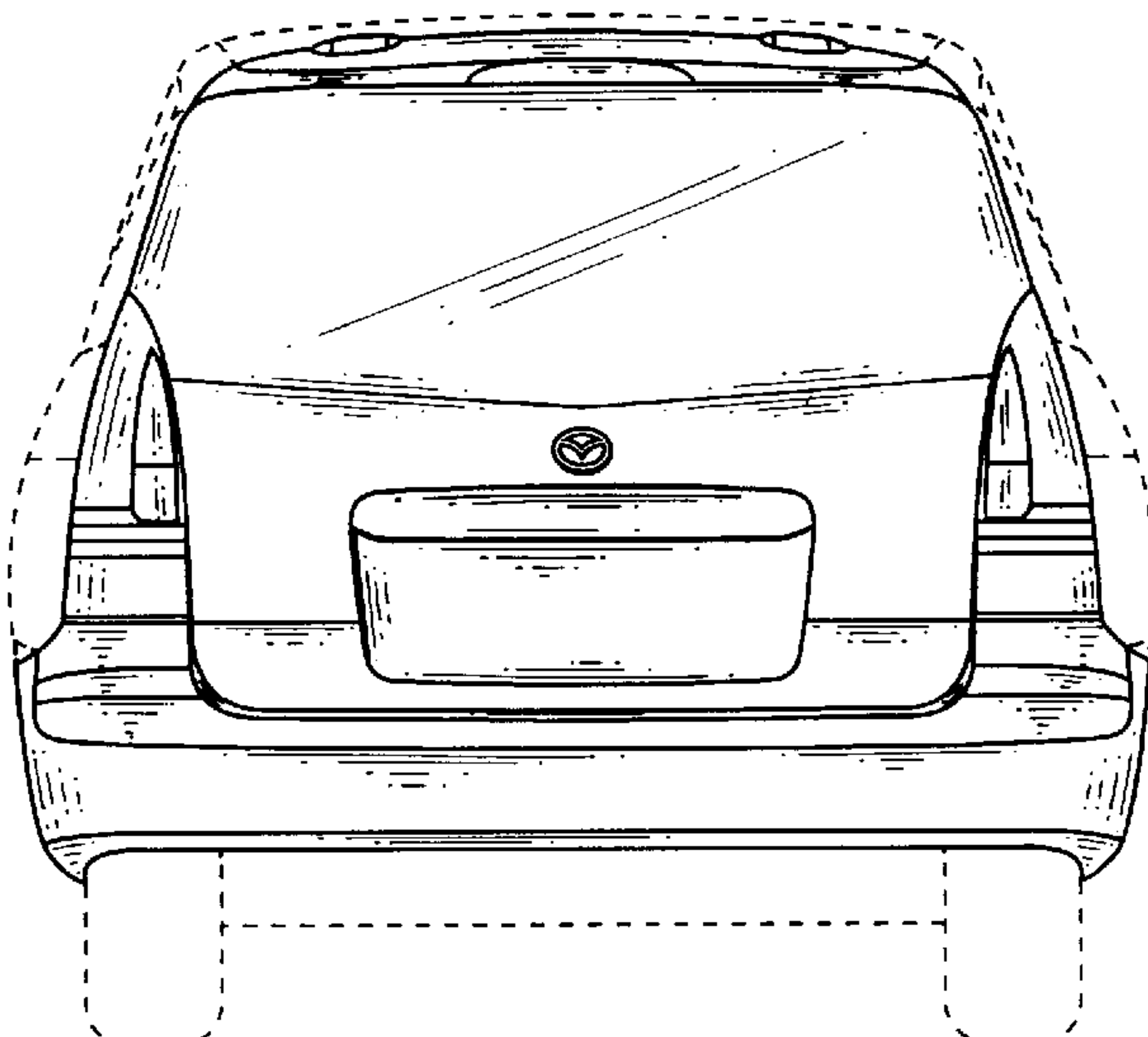

FIG. 1

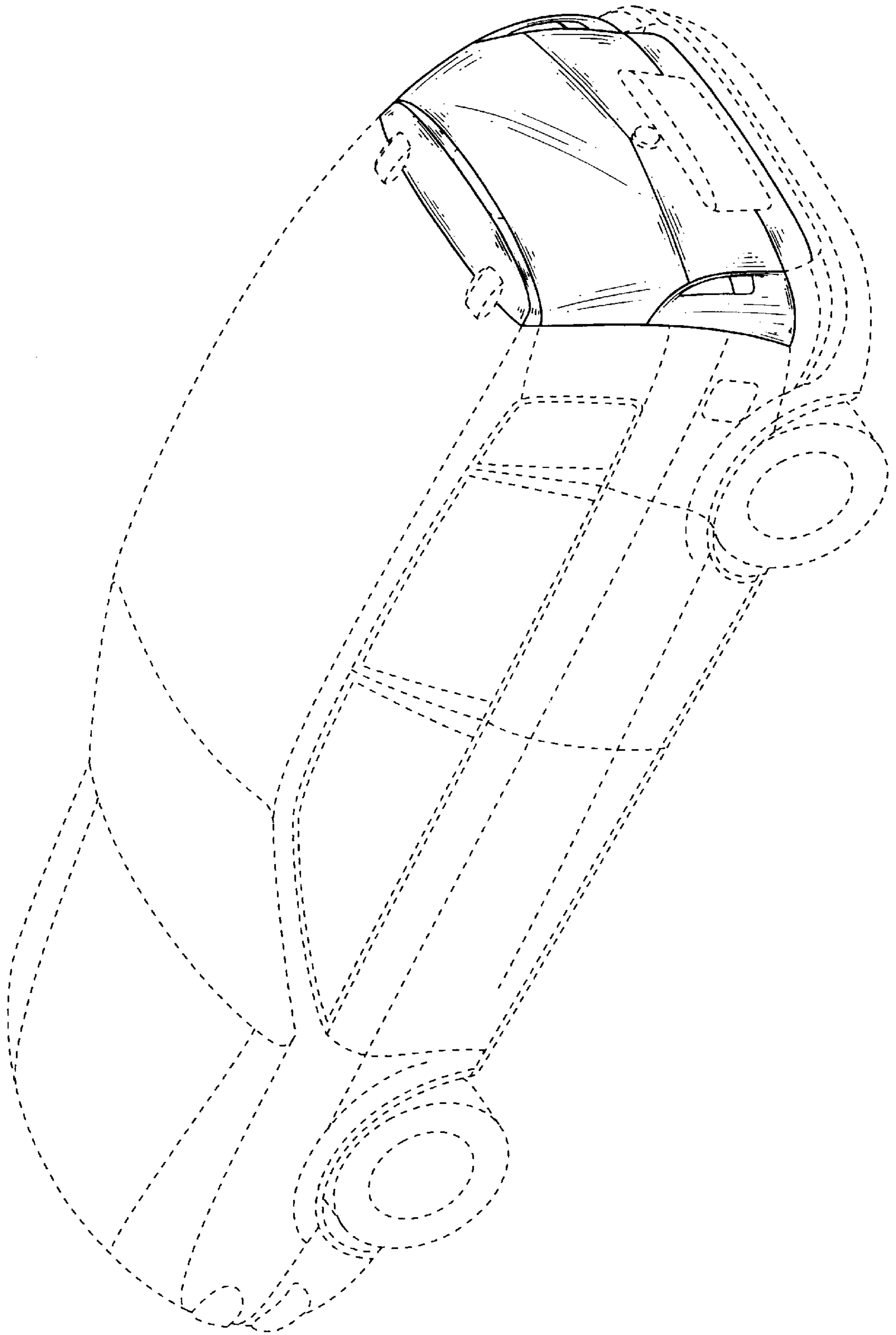

FIG. 2

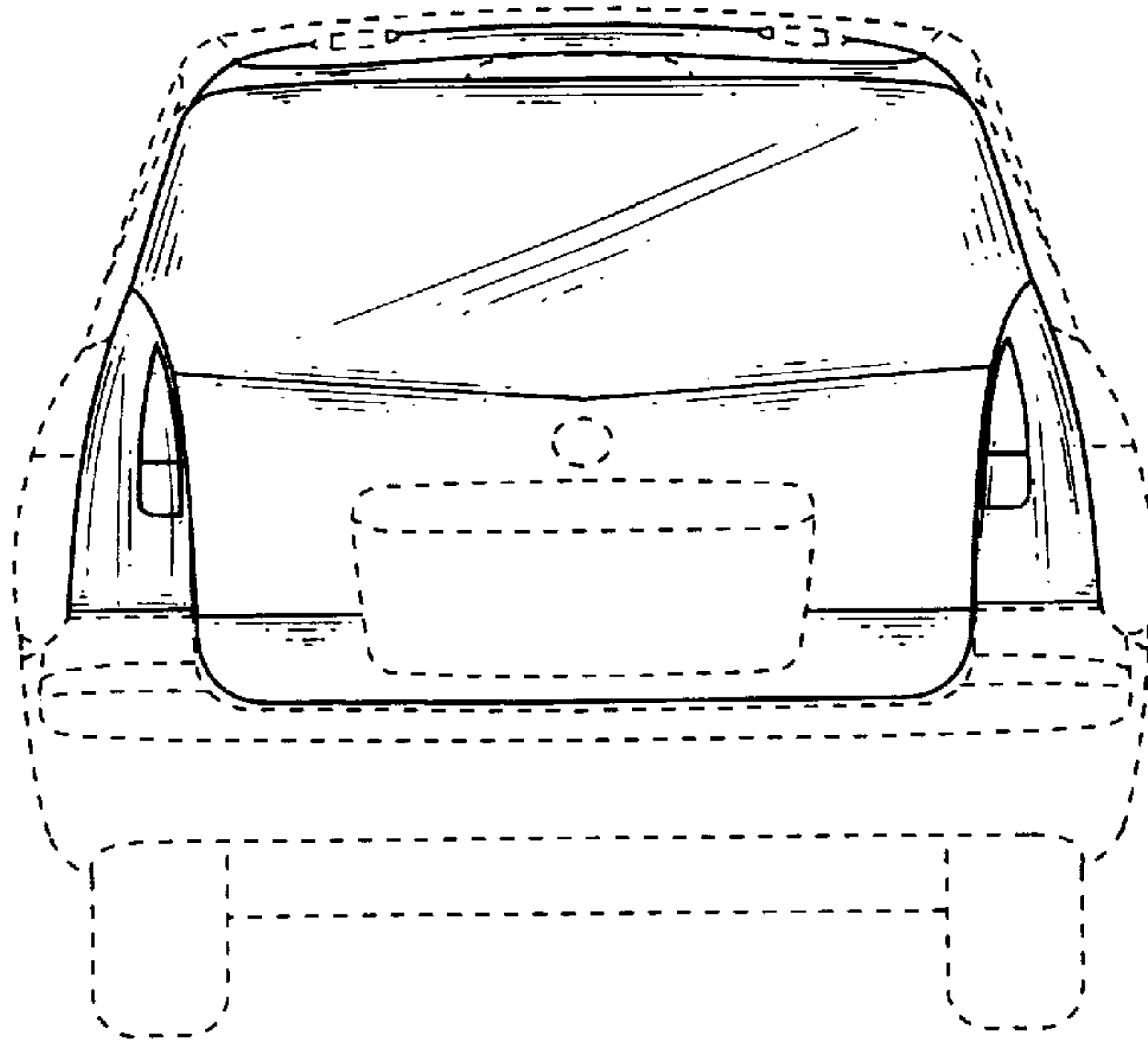

FIG. 3

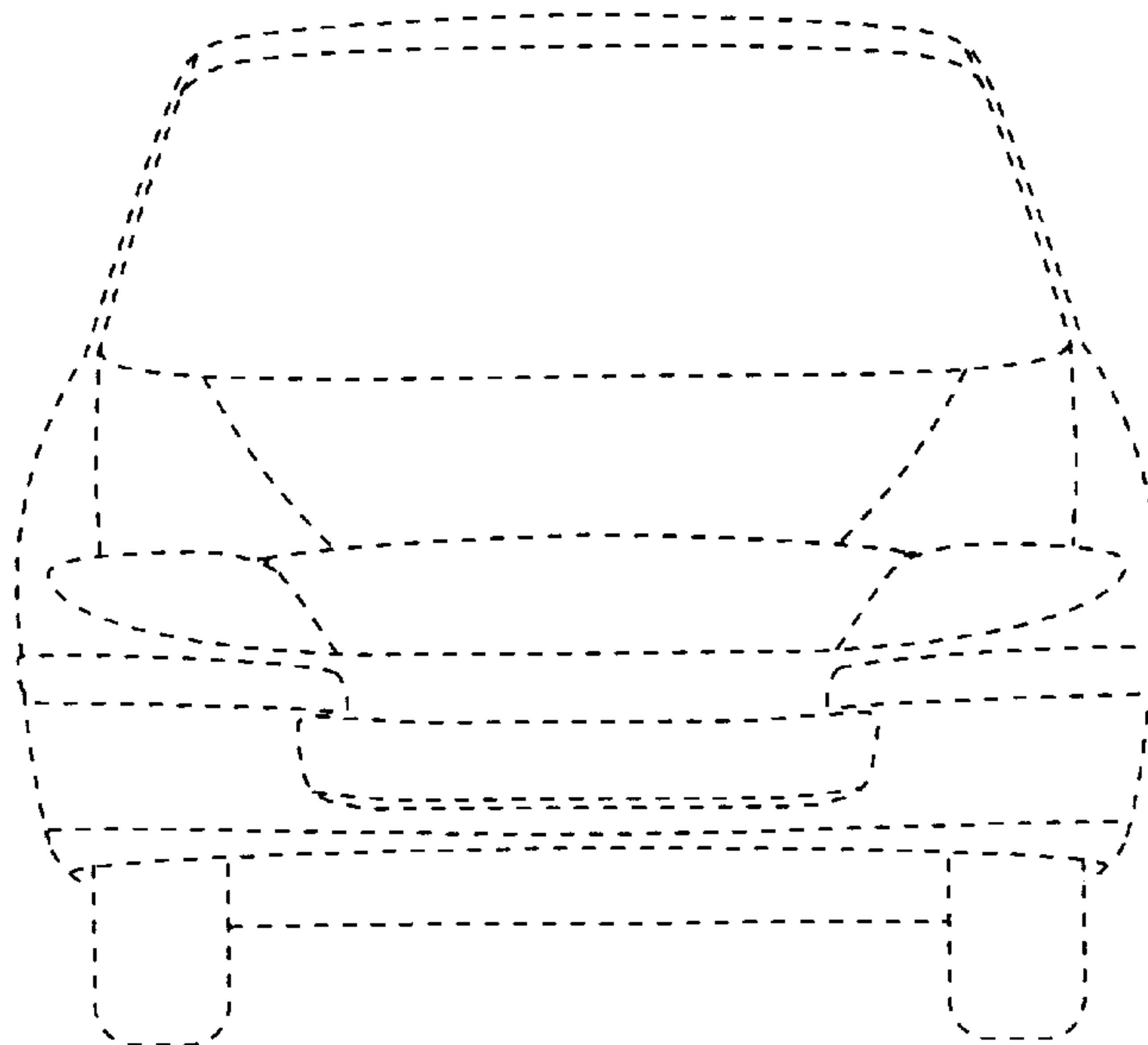

FIG. 4

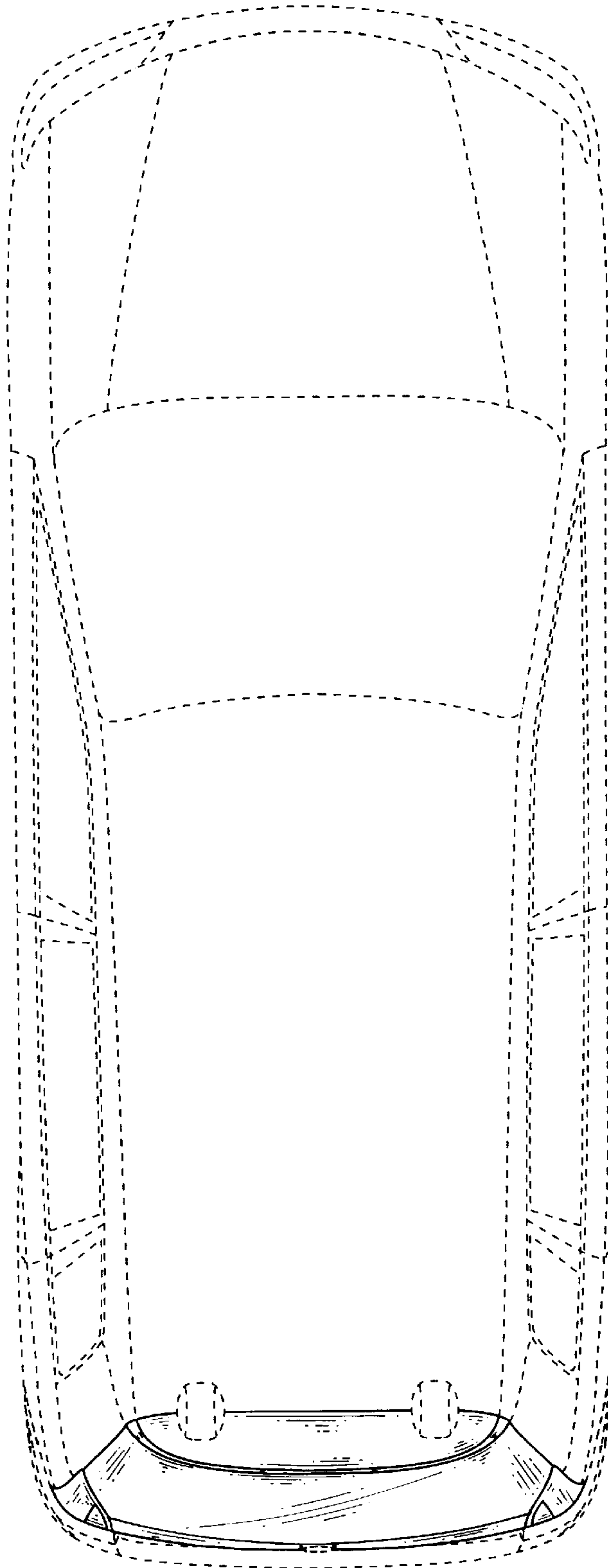

FIG. 5

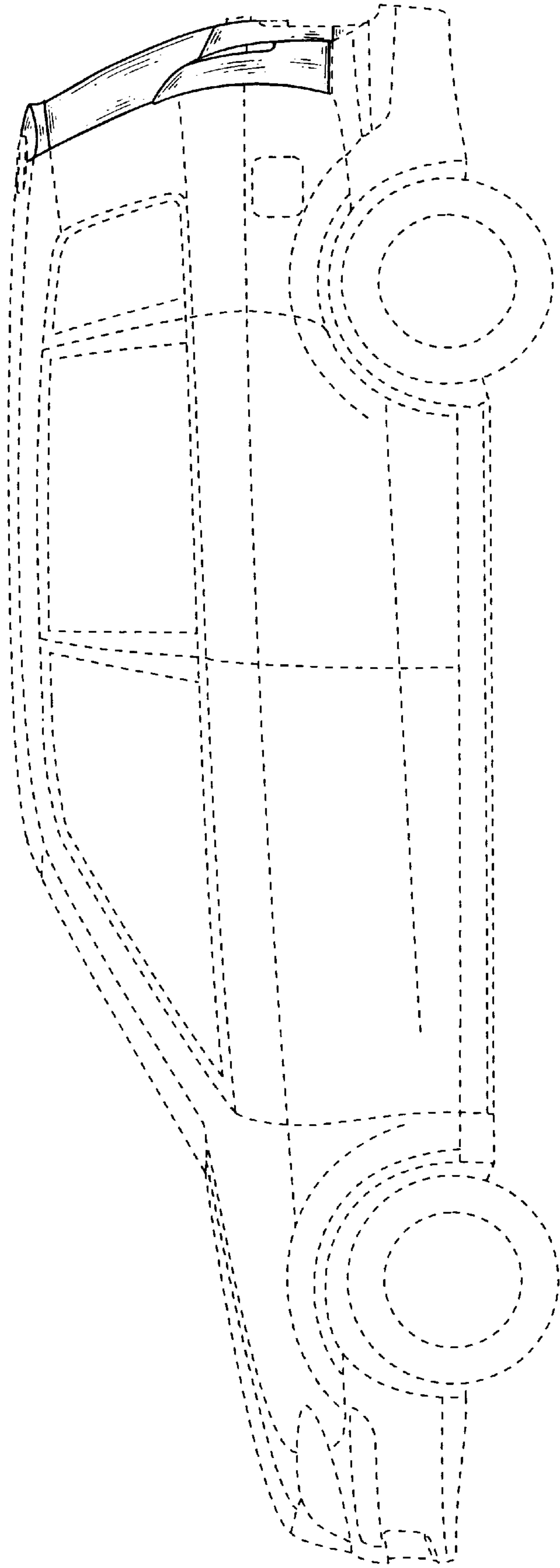

FIG. 6

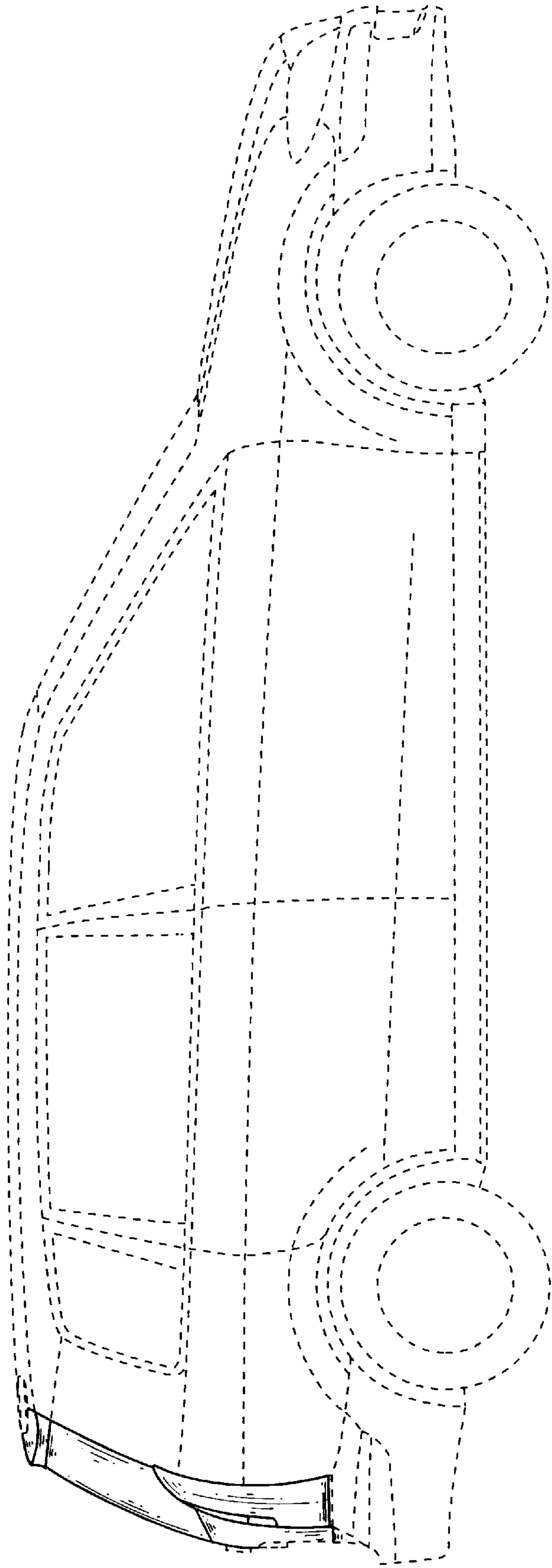

FIG. 7

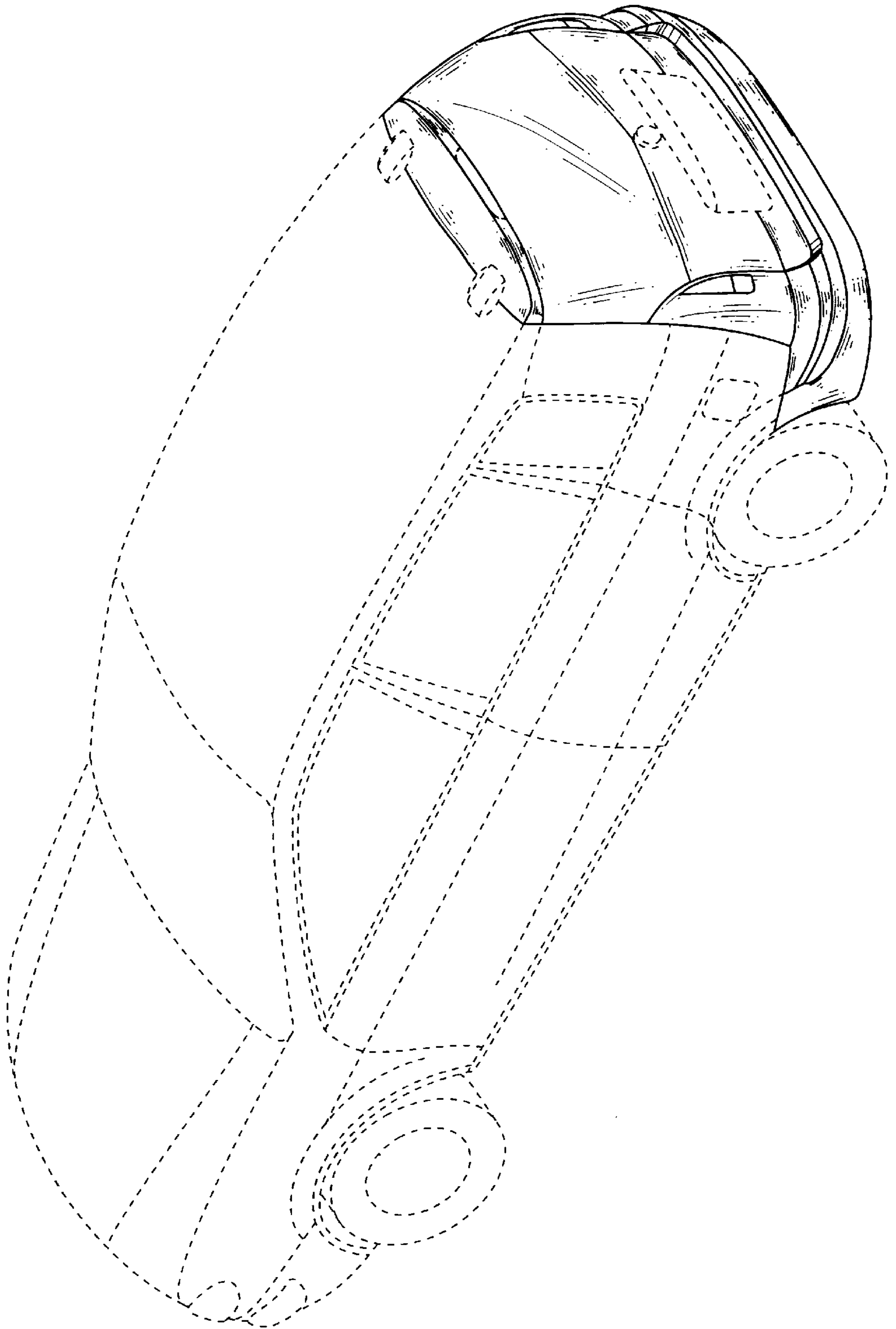

FIG. 8

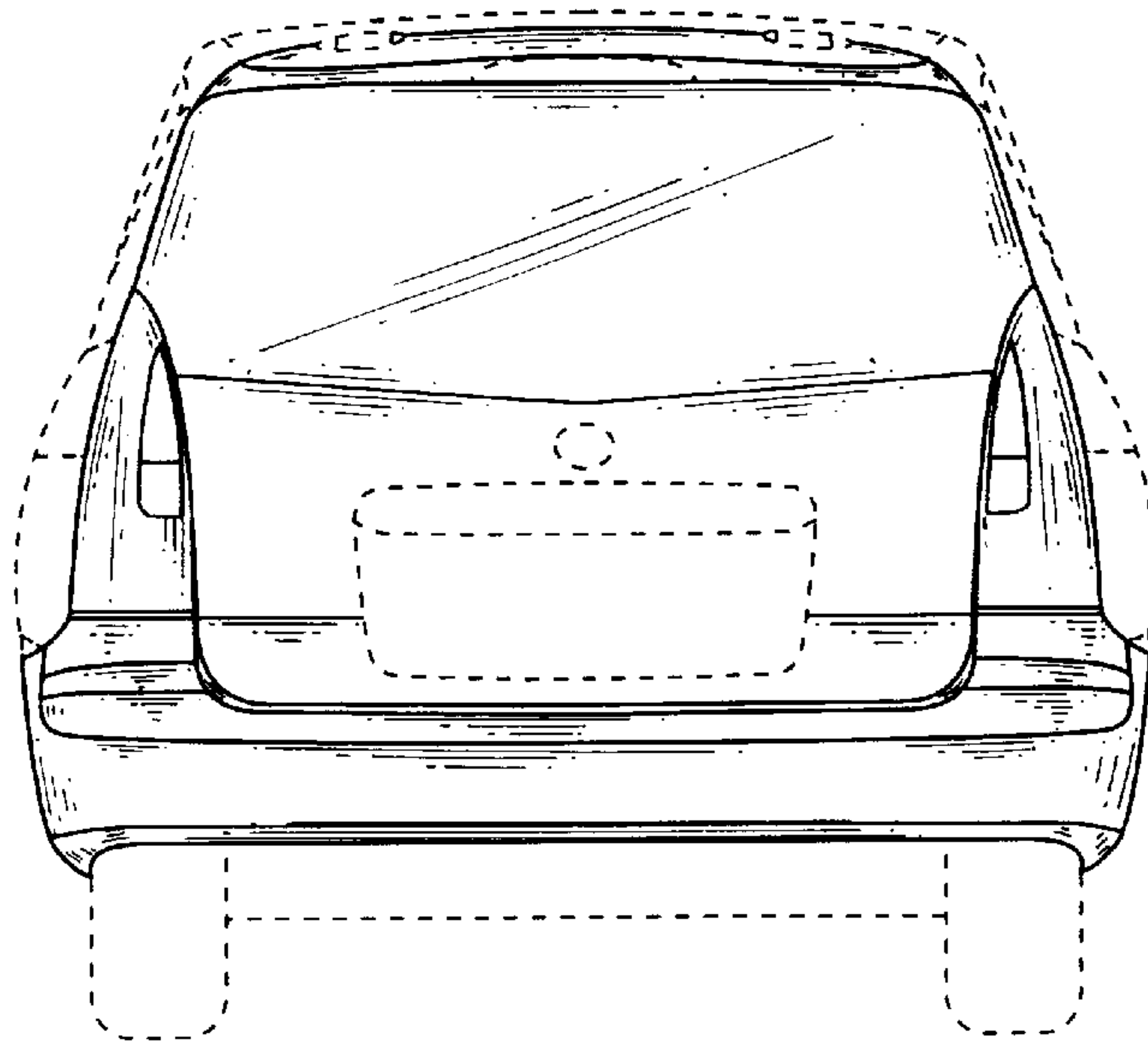

FIG. 9

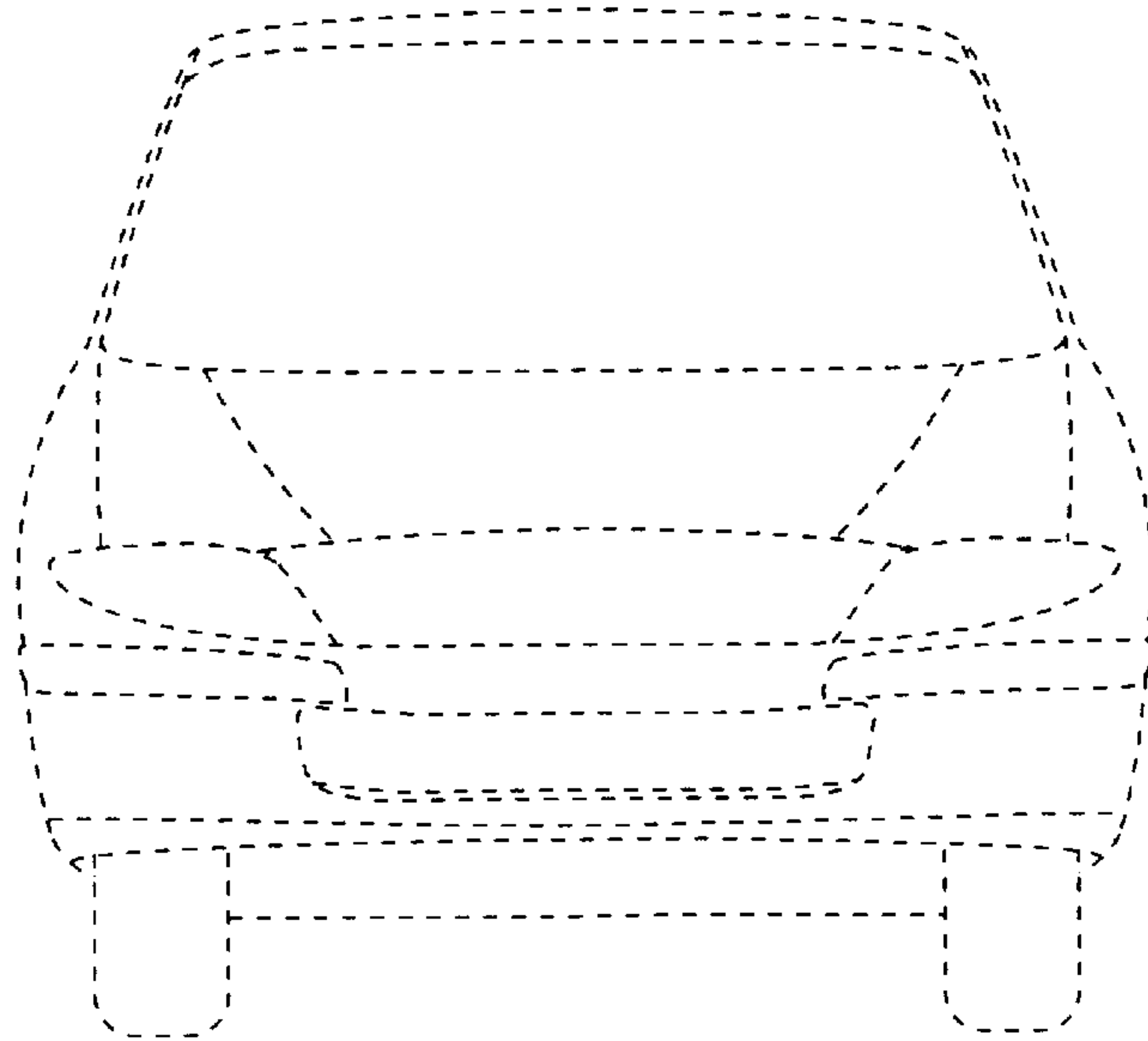

FIG. 10

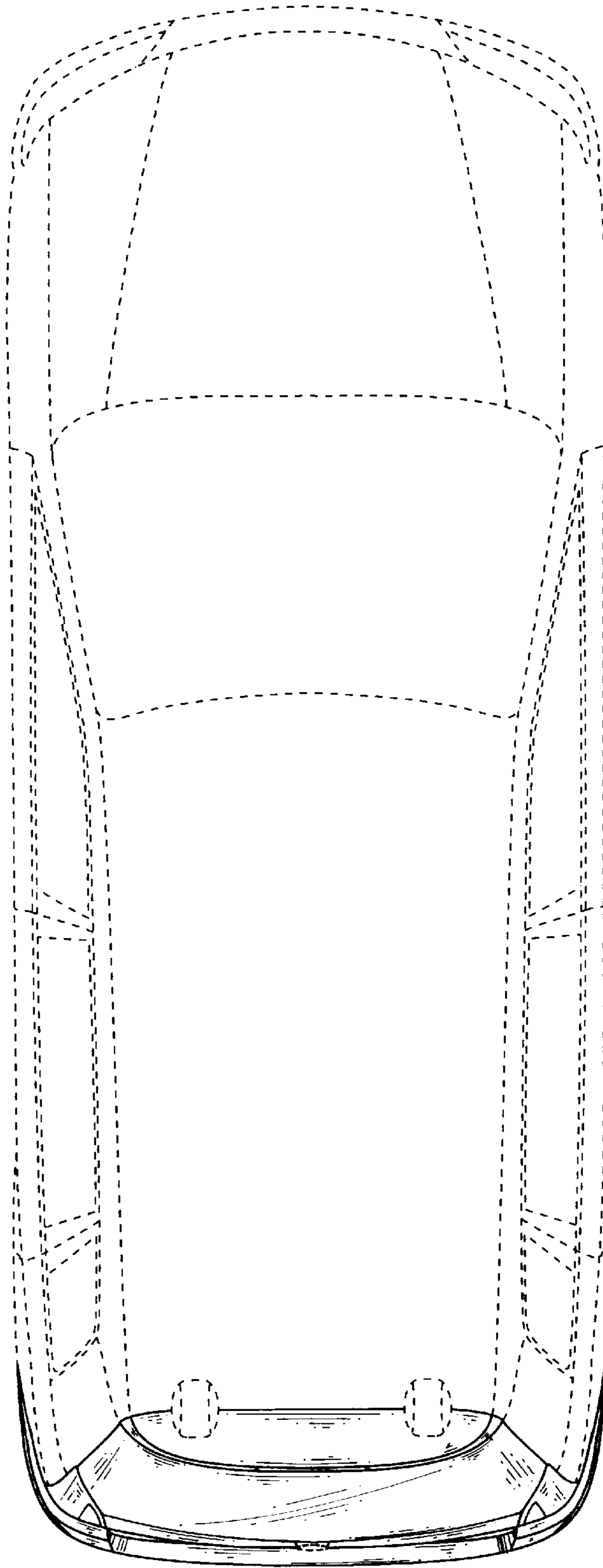

FIG. 11

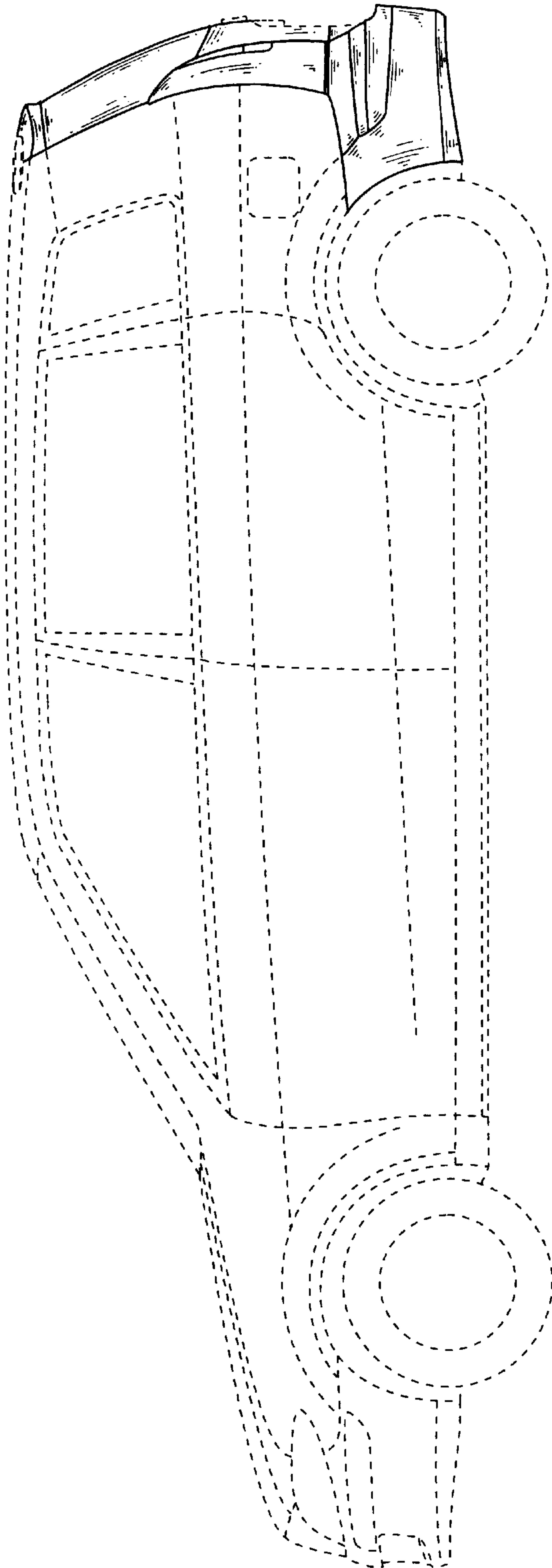

FIG. 12

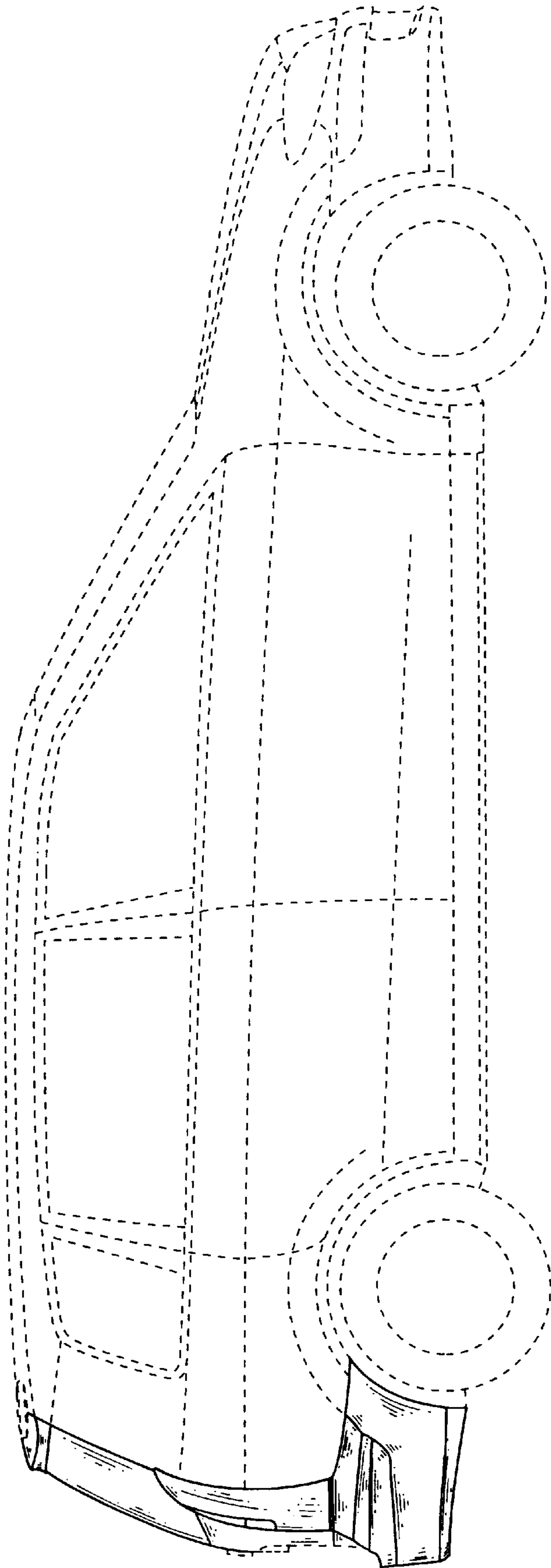

FIG. 13

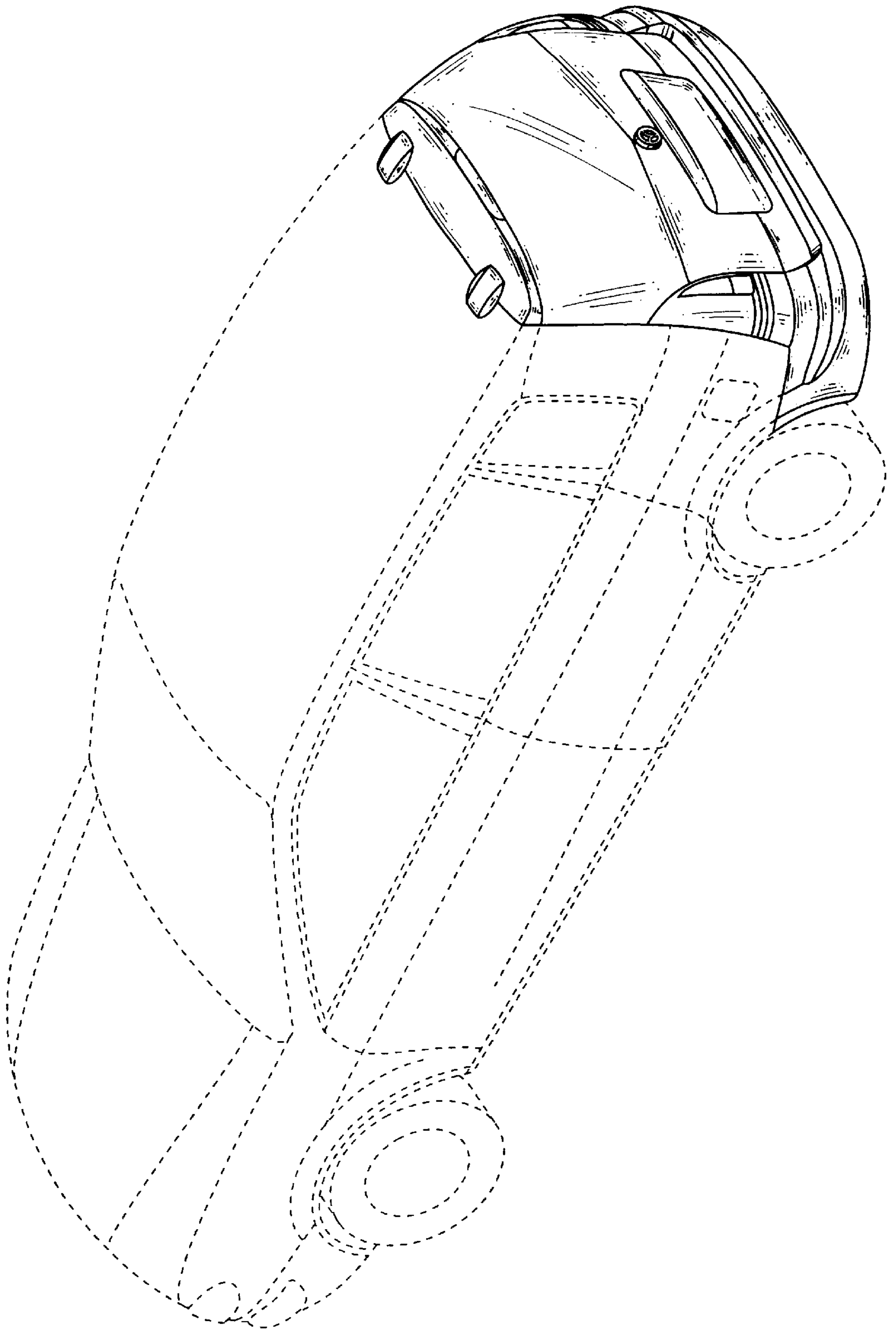

FIG. 14

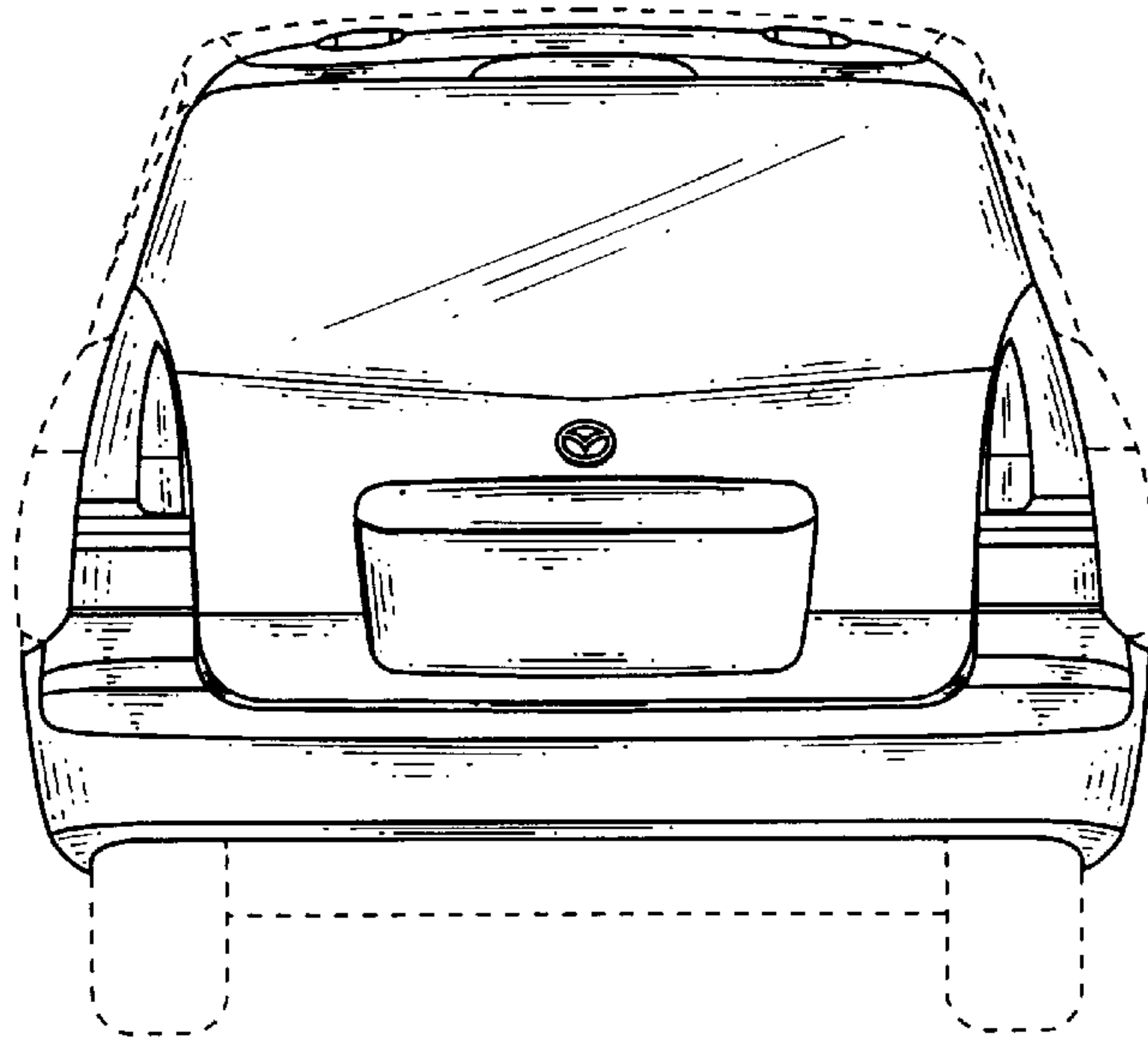

FIG. 15

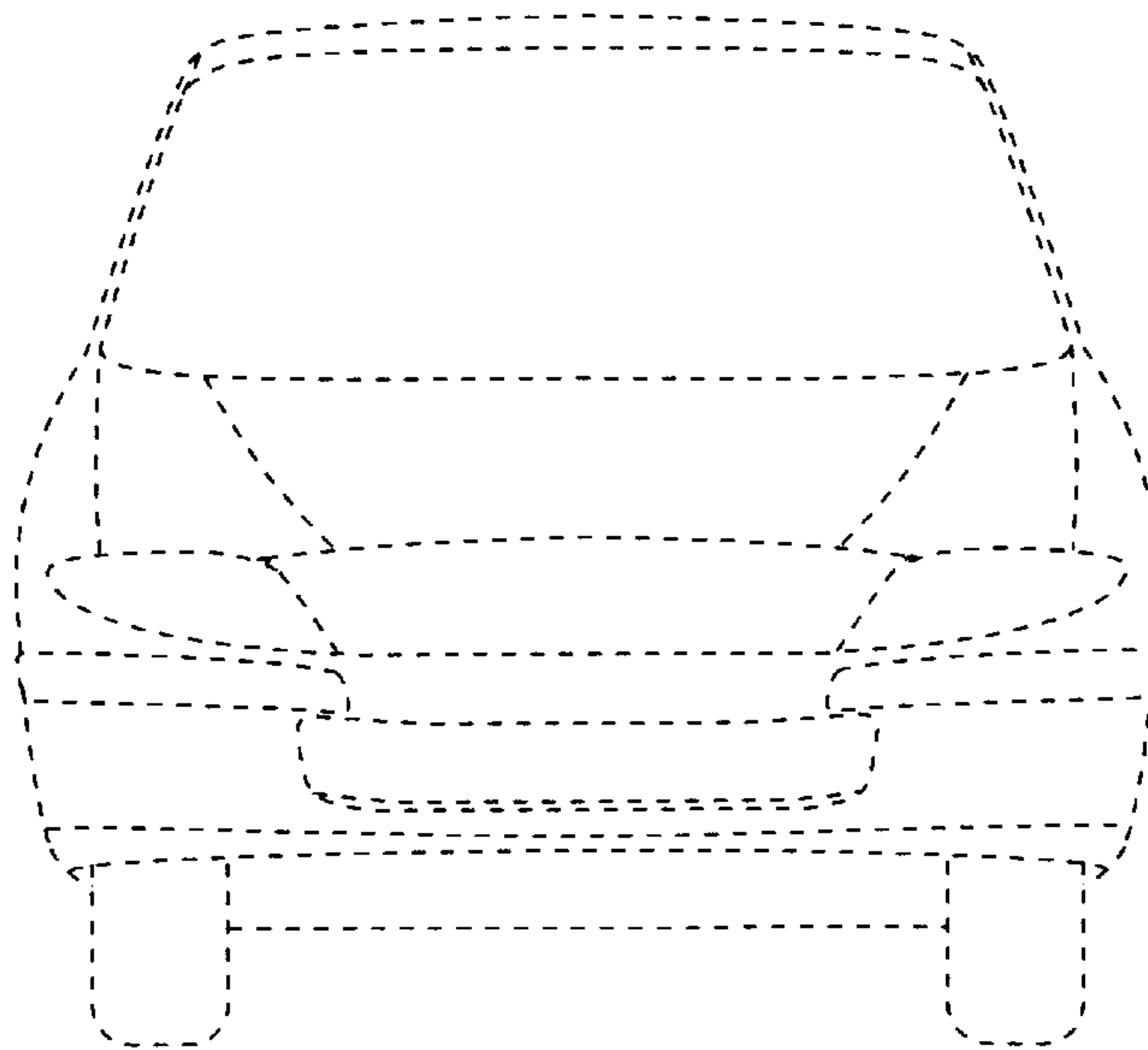

FIG. 16

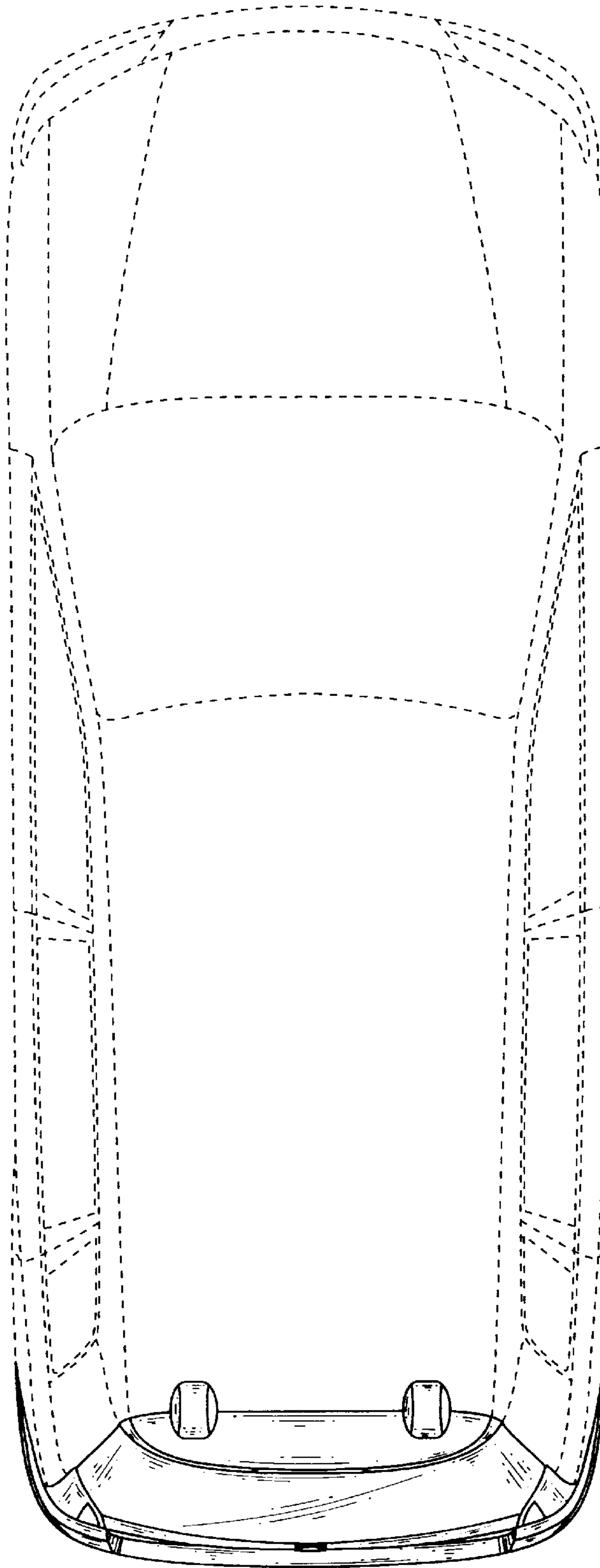

FIG. 17

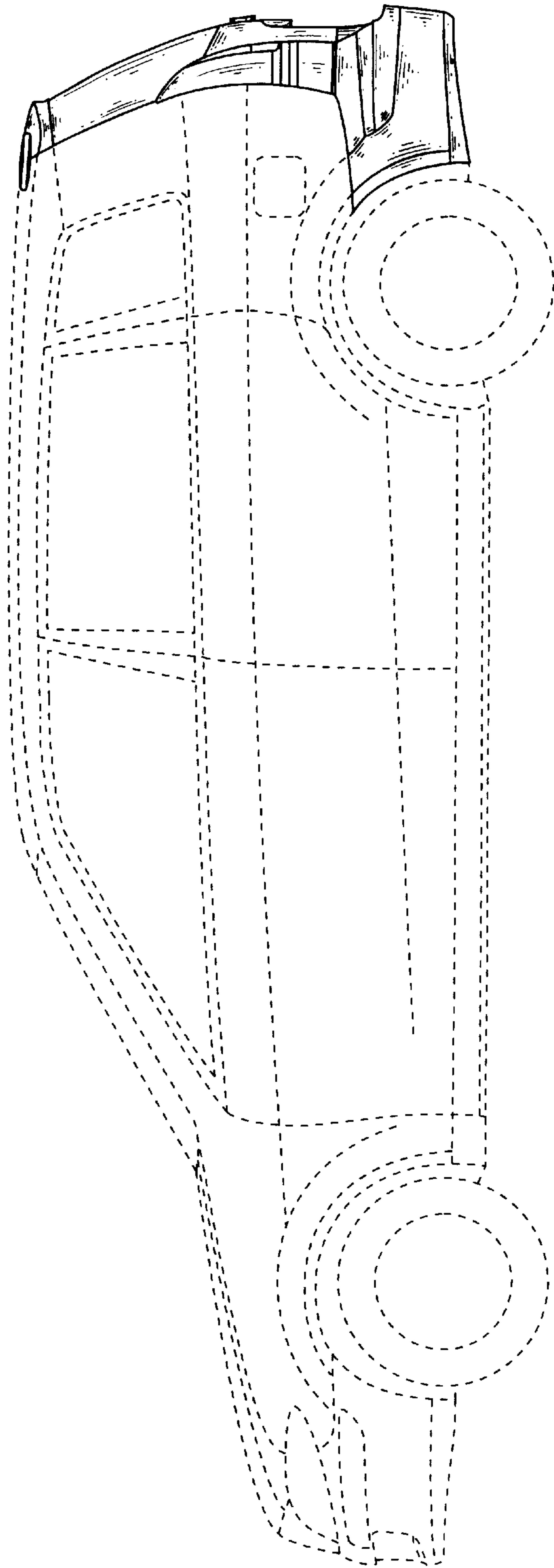

FIG. 18

