



US00D421586S

United States Patent [19]

Toms

[11] Patent Number: **Des. 421,586**

[45] Date of Patent: **** Mar. 14, 2000**

[54] **REAR IMPACT GUARD**

[75] Inventor: **Robert S. Toms**, Racine, Wis.

[73] Assignee: **Powerbrace Corporation**, Kenosha, Wis.

[**] Term: **14 Years**

[21] Appl. No.: **29/095,752**

[22] Filed: **Oct. 29, 1998**

[51] **LOC (6) Cl.** **12-16**

[52] **U.S. Cl.** **D12/167**

[58] **Field of Search** D12/167, 190, D12/400; 296/146.6; 293/126; 280/770

[56] **References Cited**

U.S. PATENT DOCUMENTS

D. 231,919	6/1974	Bruhn	D12/167
D. 323,480	1/1992	Taylor	D12/167
D. 358,358	5/1995	Burroughs	D12/167
D. 386,458	11/1997	Smith	D12/167

3,210,110	10/1965	Chieger .	
3,923,330	12/1975	Viall, Sr. et al. .	
4,247,138	1/1981	Child 293/103
5,148,886	9/1992	Parsons 180/275
5,232,261	8/1993	Kuroda 286/146.6
5,520,428	5/1996	Bell 293/118

Primary Examiner—Melody N. Brown

[57] **CLAIM**

The ornamental design for a rear impact guard, as shown and described.

DESCRIPTION

FIG. 1 is a perspective view of a rear impact guard showing my new design;
FIG. 2 is a right end elevational view thereof;
FIG. 3 is a left end elevational view thereof;
FIG. 4 is a top plan view thereof;
FIG. 5 is a front elevational view thereof;
FIG. 6 is a bottom plan view thereof; and,
FIG. 7 is a rear elevational view thereof.

1 Claim, 2 Drawing Sheets

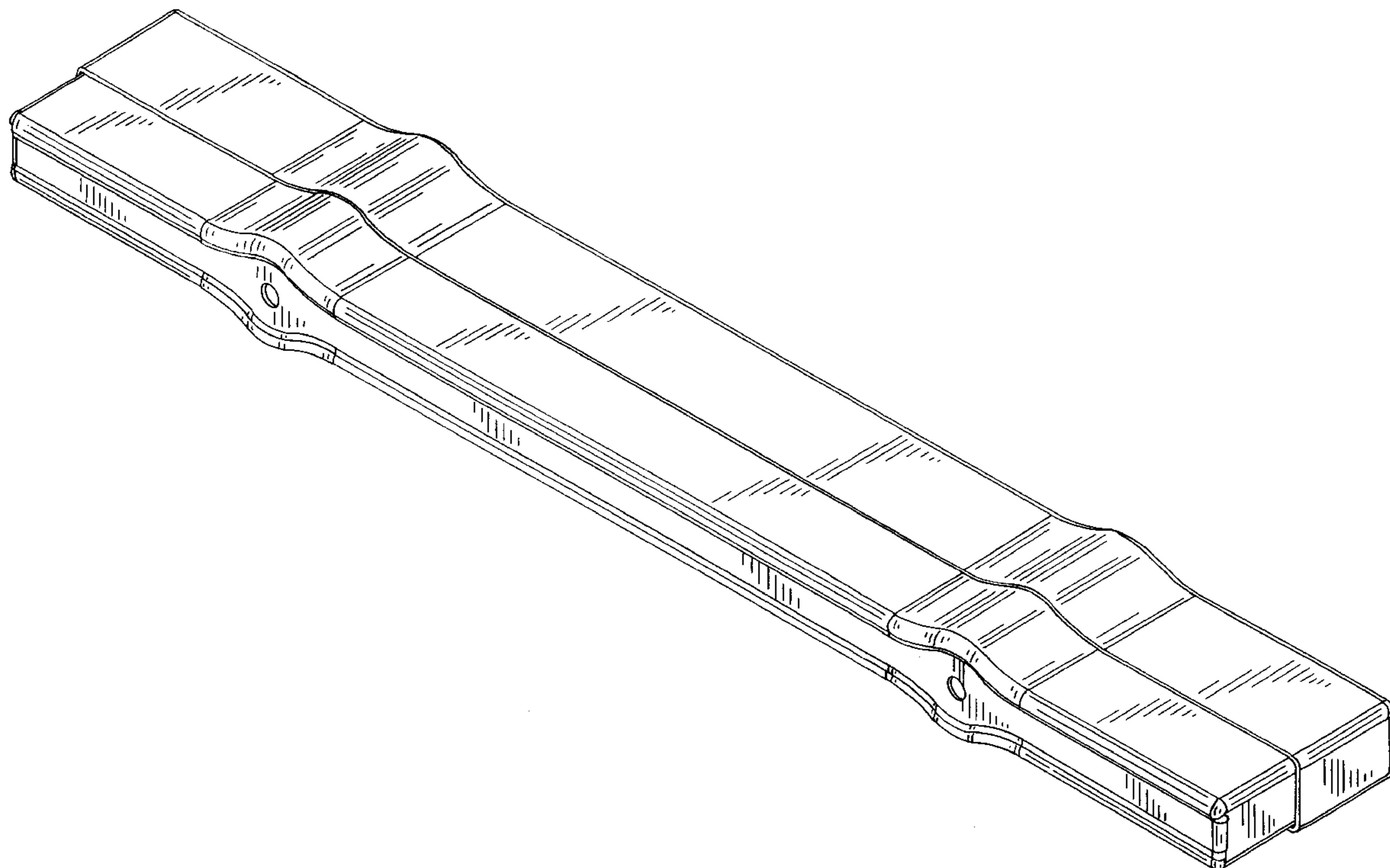

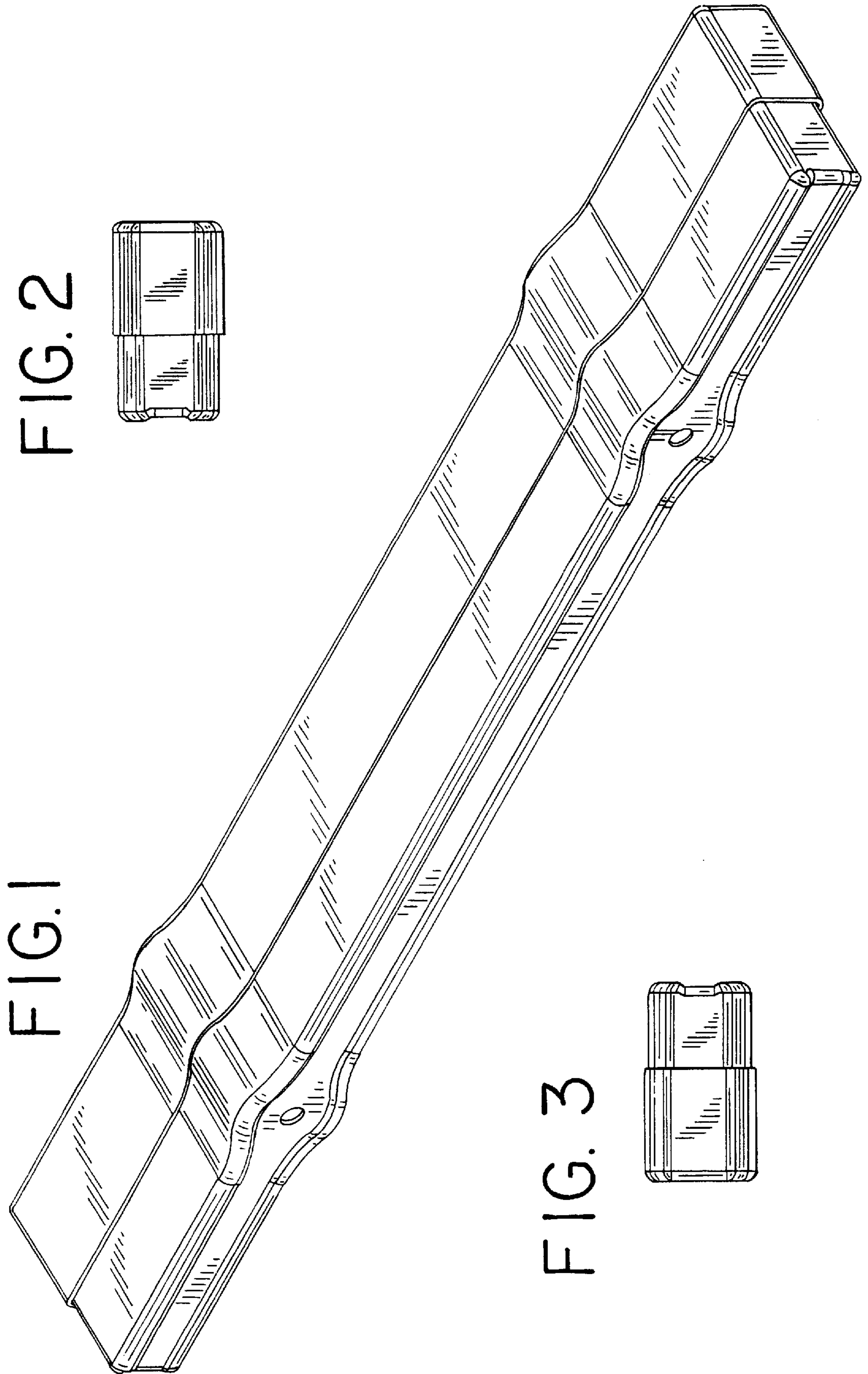

FIG. 1

FIG. 2

FIG. 3

FIG. 4

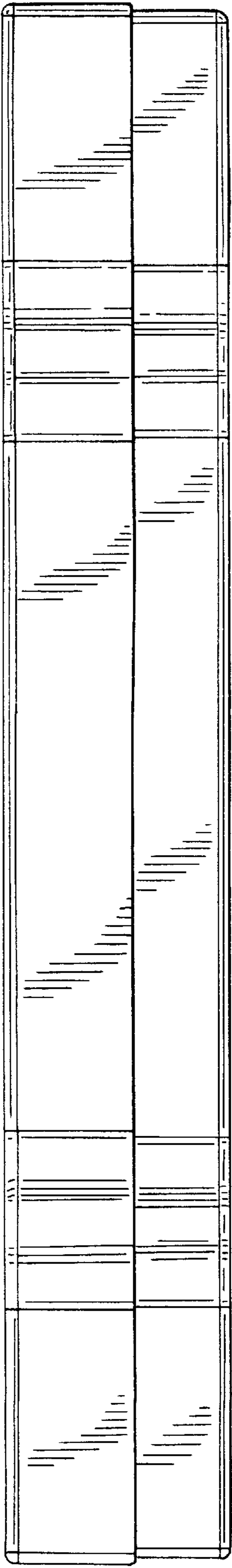

FIG. 5

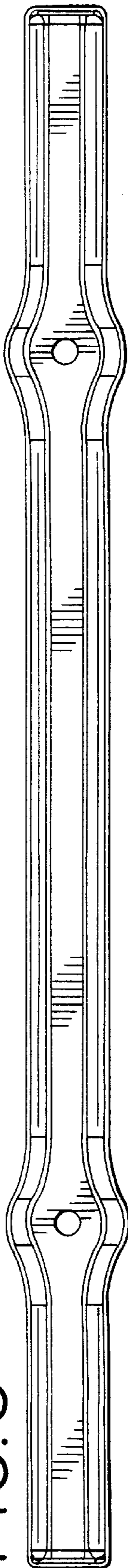

FIG. 6

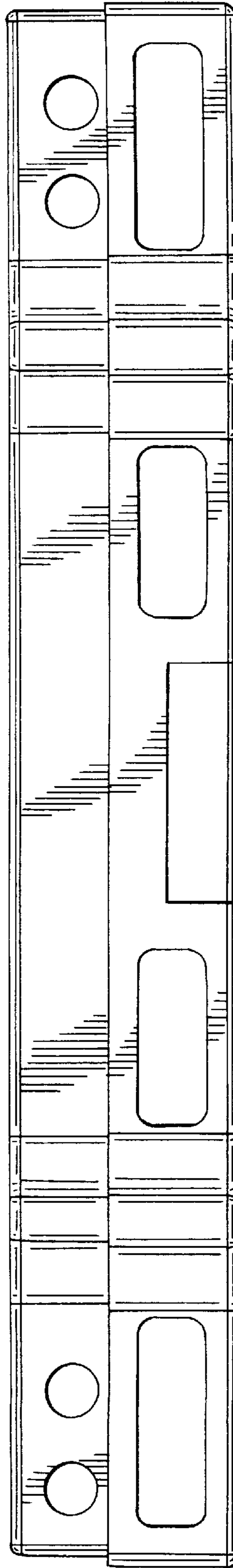

FIG. 7

