



US00D421296S

# United States Patent [19] Kemp

[11] Patent Number: **Des. 421,296**

[45] Date of Patent: **\*\* Feb. 29, 2000**

[54] **BURNER**

[75] Inventor: **Brendan Kemp**, Bessels Green, United Kingdom

[73] Assignee: **Limpsfield Combustion Ltd.**,  
Limpsfield, United Kingdom

[\*\*] Term: **14 Years**

[21] Appl. No.: **29/081,838**

[22] Filed: **Dec. 19, 1997**

[51] **LOC (6) Cl.** ..... **23-03**

[52] **U.S. Cl.** ..... **D23/314; D23/319; D23/329**

[58] **Field of Search** ..... D23/314, 329,  
D23/342, 319; 431/258, 159, 157, 195,  
196, 351

[56] **References Cited**

**U.S. PATENT DOCUMENTS**

D. 31,010	6/1899	Vanes .....	D23/319
D. 372,524	8/1996	Tonini .....	D23/314
2,077,043	4/1937	Gehrich .	

2,693,941	11/1954	Bystrom .	
4,978,293	12/1990	Ryno .....	431/258
5,096,412	3/1992	Lanza et al. ....	431/158
5,458,483	10/1995	Taylor .....	431/351

**OTHER PUBLICATIONS**

Data Sheet regarding Oertli Indumatik Burner (undated).  
Nu Way Burner (undated).  
Webster Burner (undated).

*Primary Examiner*—B. J. Bullock  
*Attorney, Agent, or Firm*—Merchant & Gould P.C.

[57] **CLAIM**

The ornamental design for a burner, as shown and described.

**DESCRIPTION**

FIG. 1 perspective view  
FIG. 2 side view  
FIG. 3 plan view  
FIG. 4 view taken from the left side of FIG. 2.  
FIG. 5 view taken from the right side of FIG. 2; and,  
FIG. 6 underneath view.

**1 Claim, 3 Drawing Sheets**

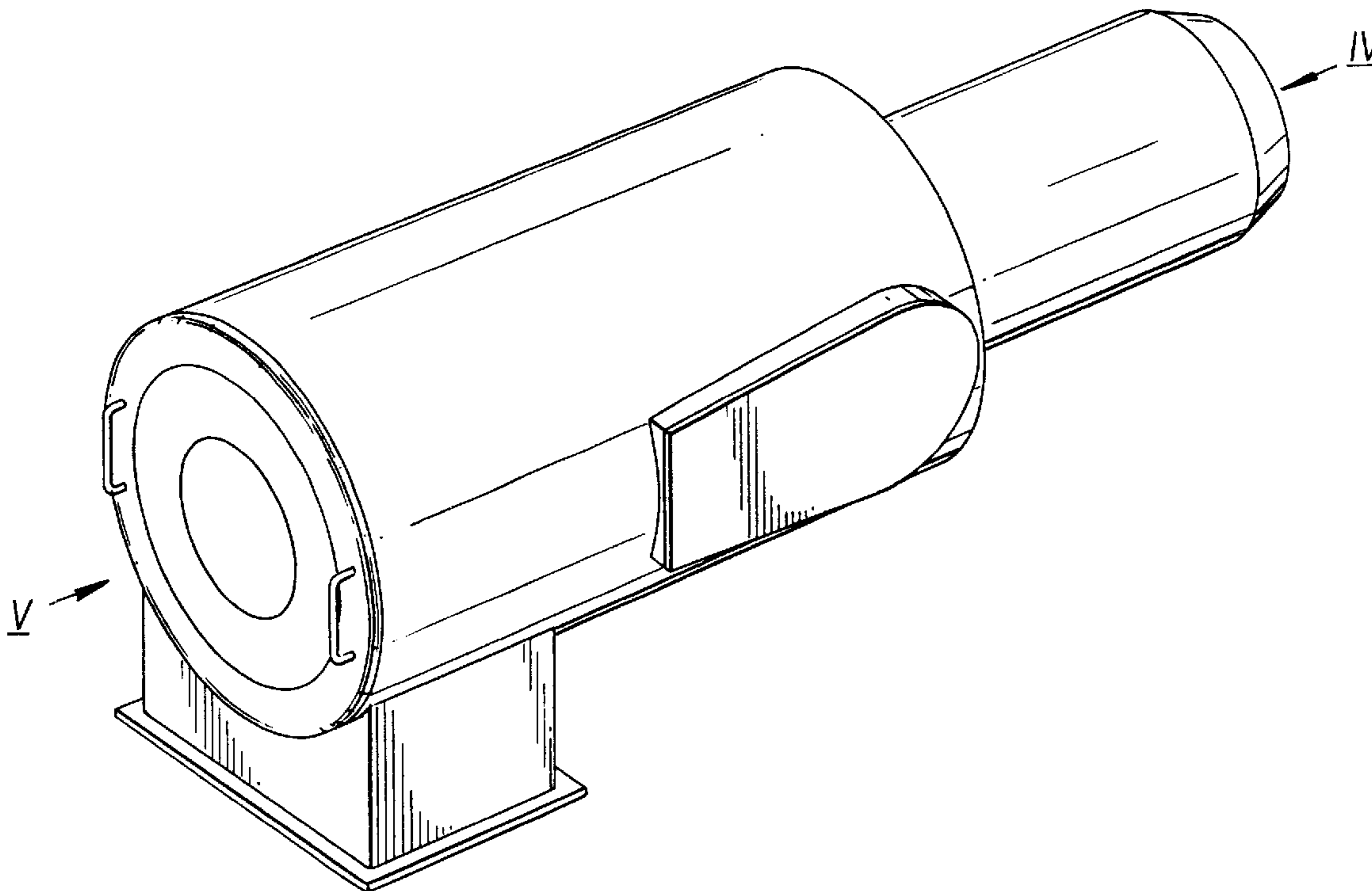

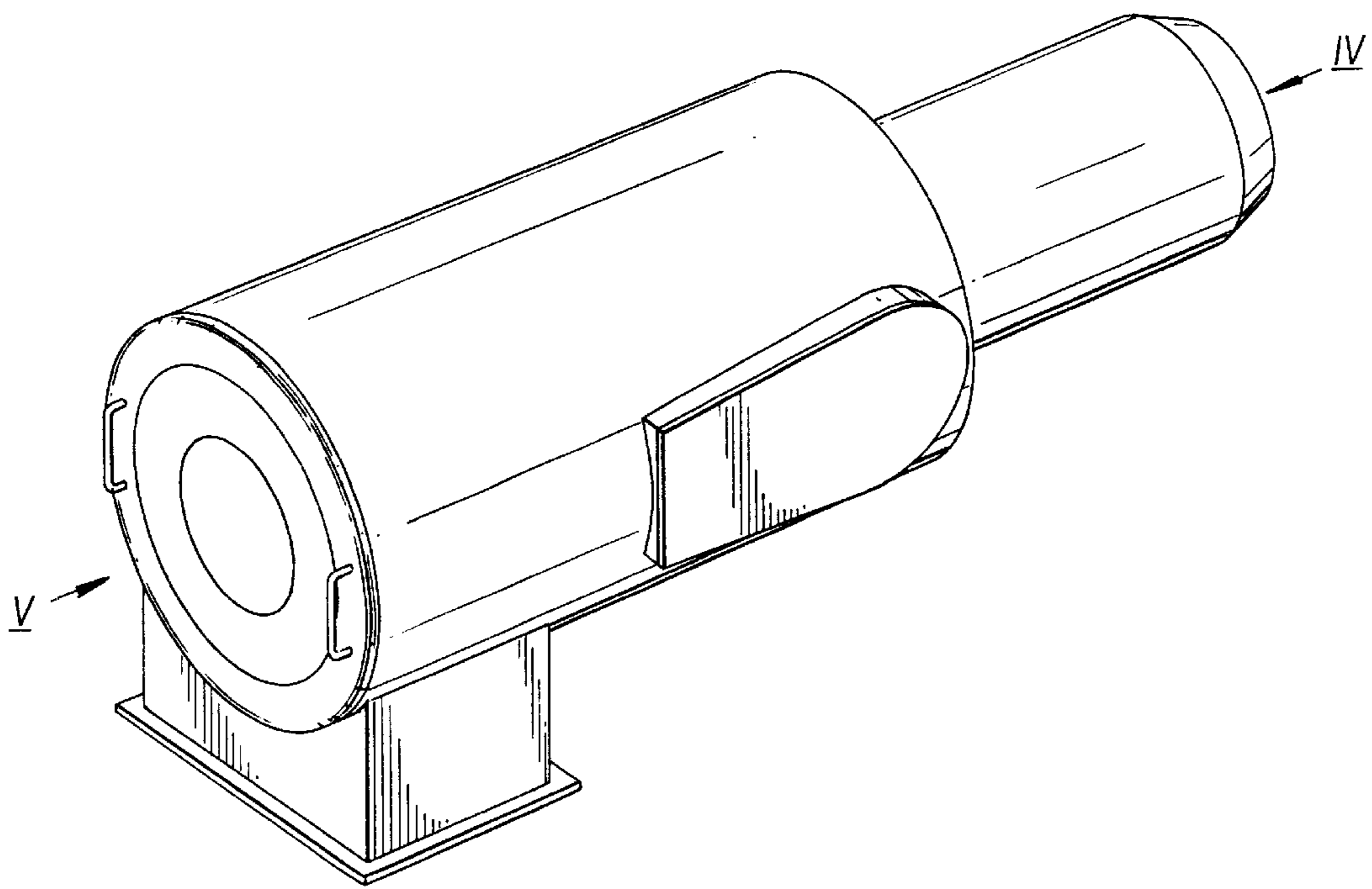
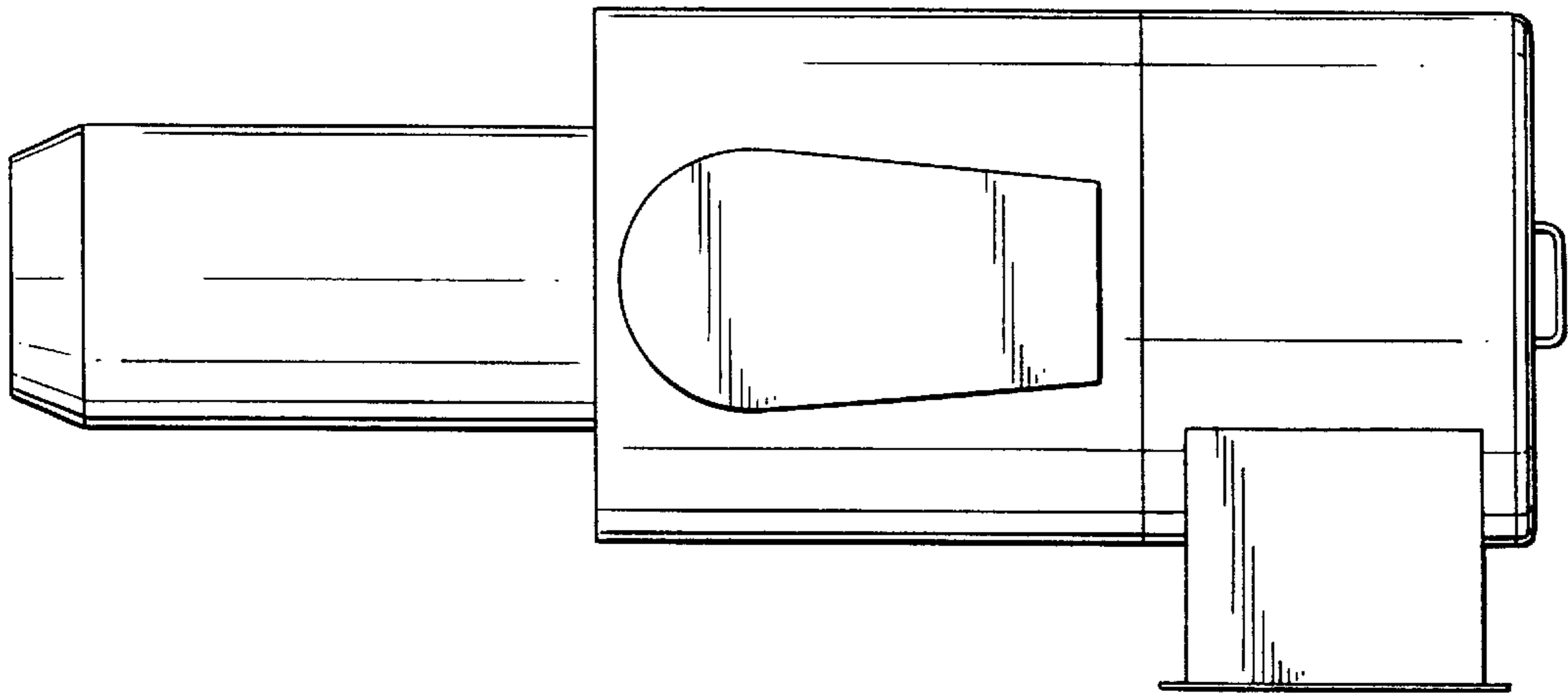
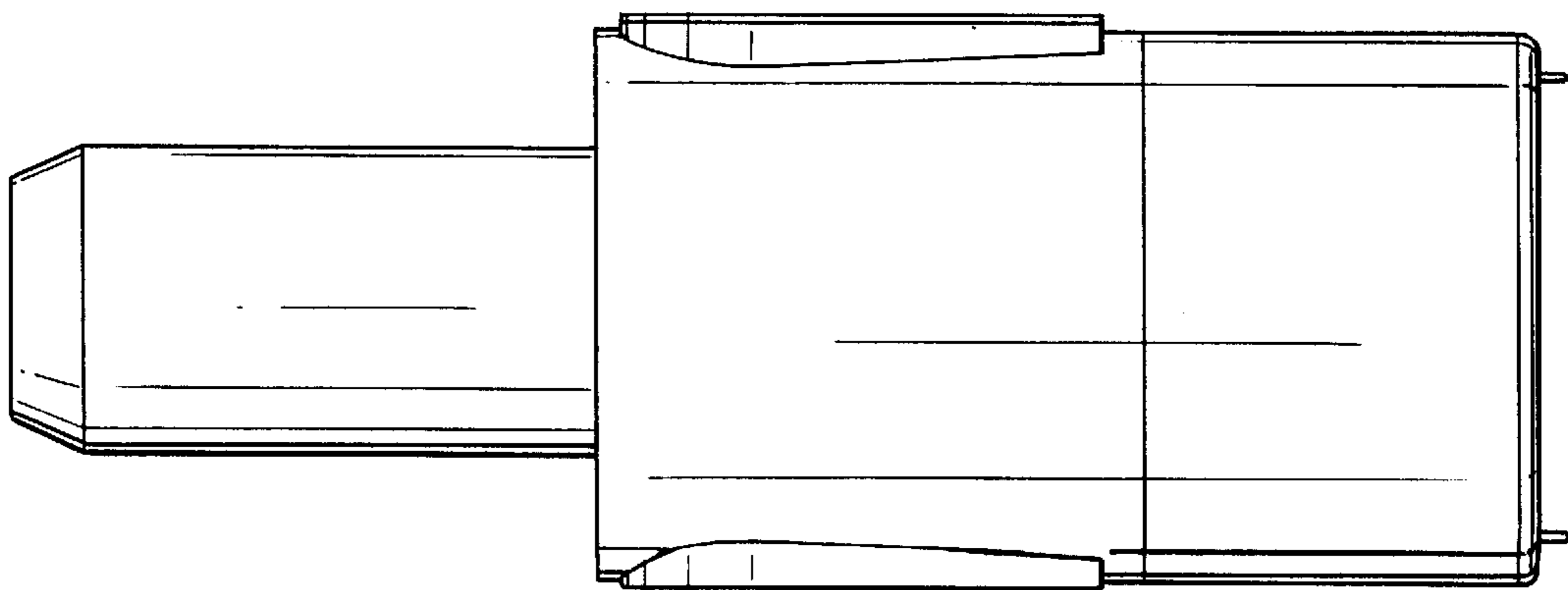

Fig. 1



*Fig. 2*



*Fig. 3*

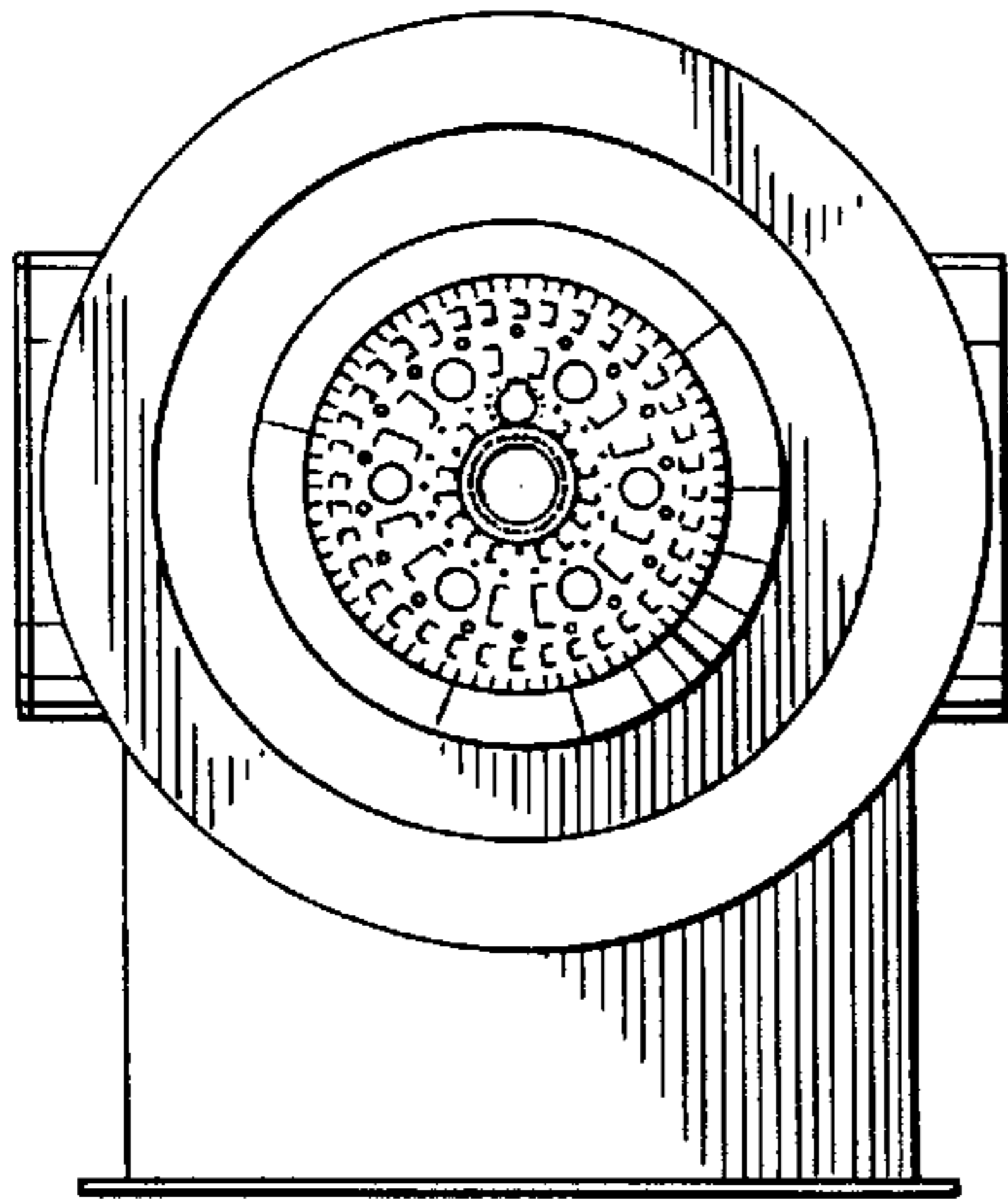

*Fig. 4*

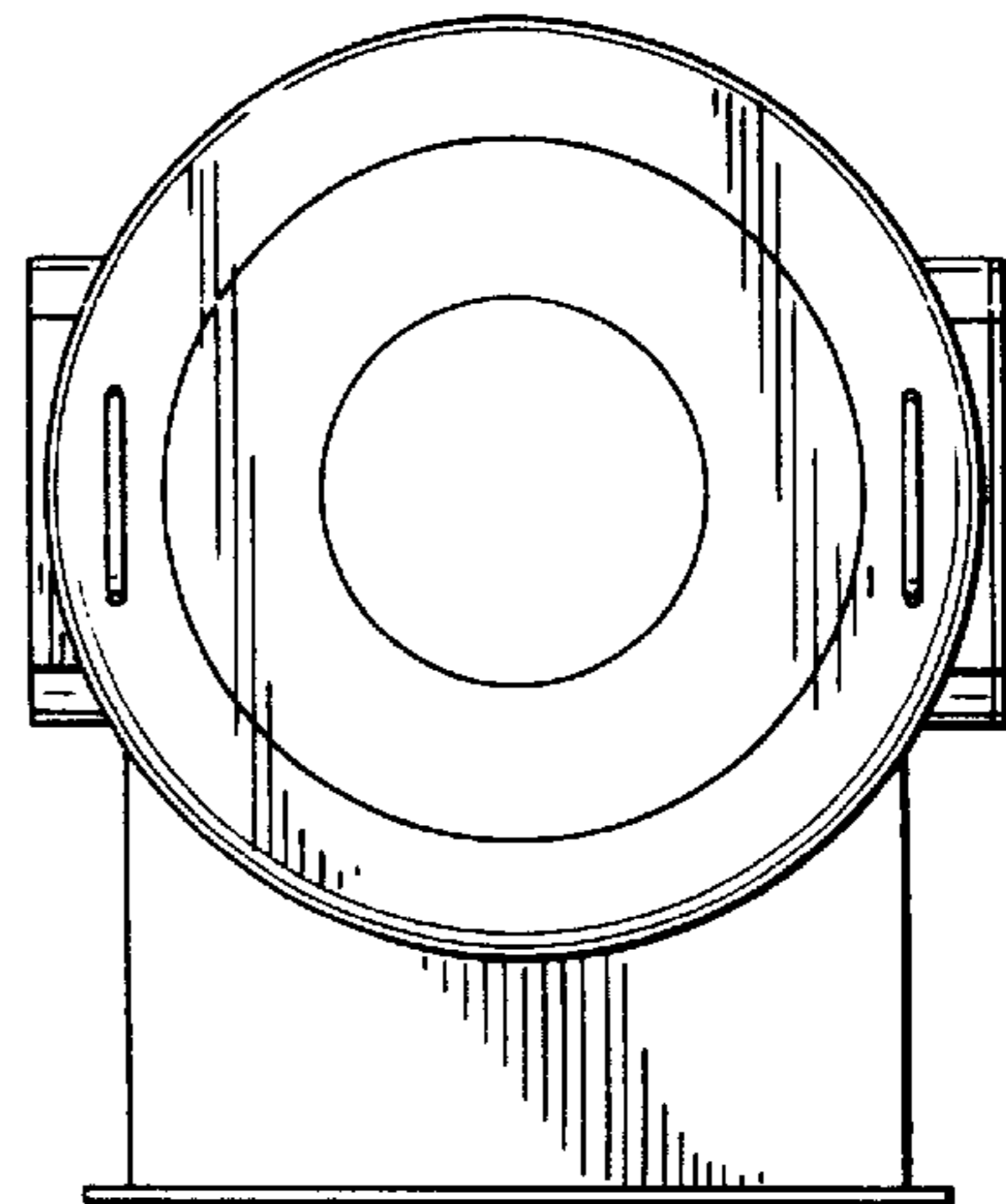

*Fig. 5*

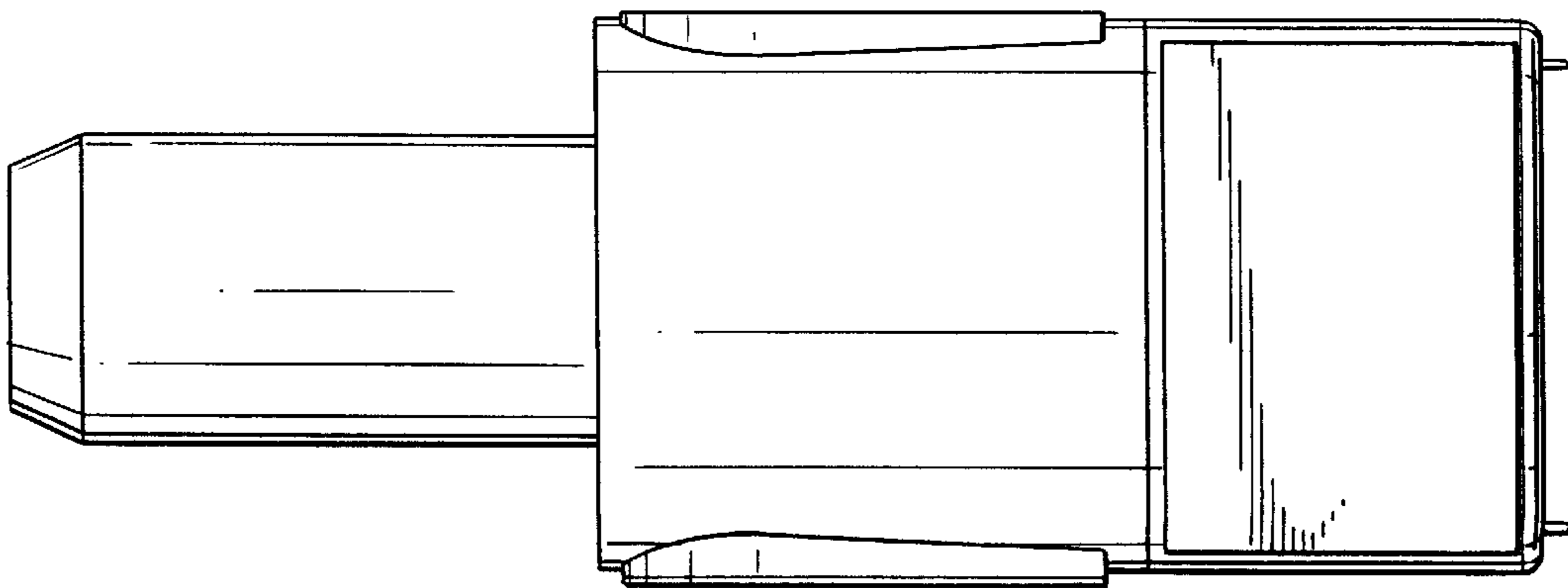

*Fig. 6*