



US00D421240S

United States Patent [19]
Forbes-Robinson

[11] **Patent Number: Des. 421,240**

[45] **Date of Patent: ** Feb. 29, 2000**

[54] **AUTOMOBILE BODY**

[75] Inventor: **Elliott Forbes-Robinson**, Sherrills Ford, N.C.

[73] Assignee: **600 Racing, Inc.**, Concord, N.C.

[**] Term: **14 Years**

[21] Appl. No.: **29/068,669**

[22] Filed: **Mar. 18, 1997**

[51] **LOC (6) Cl.** **12-08**

[52] **U.S. Cl.** **D12/92**

[58] **Field of Search** **D12/90-92; 296/185**

[56] **References Cited**

U.S. PATENT DOCUMENTS

- D. 356,982 4/1995 Ramaciotti D12/92
- D. 389,436 1/1998 Ramaciotti D12/92
- D. 401,890 12/1998 Larson et al. D12/91
- D. 411,138 6/1999 Ramaciotti D12/92

OTHER PUBLICATIONS

- 1937 Ford Coupe, Daytona International Speedway, Daytona, Florida, Feb. 1993.
- 1937 Ford Sedan, Charlotte Motor Speedway, Charlotte, North Carolina, Mar. 1993.

1937 Chevy Coupe, Charlotte Motor Speedway, Charlotte, North Carolina, Apr. 1993.

Primary Examiner—Melody N. Brown
Attorney, Agent, or Firm—Alston & Bird LLP

[57] **CLAIM**

The ornamental design for an automobile body, as shown and described.

DESCRIPTION

- FIG. 1 is a front perspective view of an automobile body showing our new design;
- FIG. 2 is a right side elevational view thereof;
- FIG. 3 is a top plan view thereof;
- FIG. 4 is a left side elevational view thereof;
- FIG. 5 is a front elevational view thereof;
- FIG. 6 is a rear elevational view thereof; and,
- FIG. 7 is a rear perspective view thereof.

1 Claim, 2 Drawing Sheets

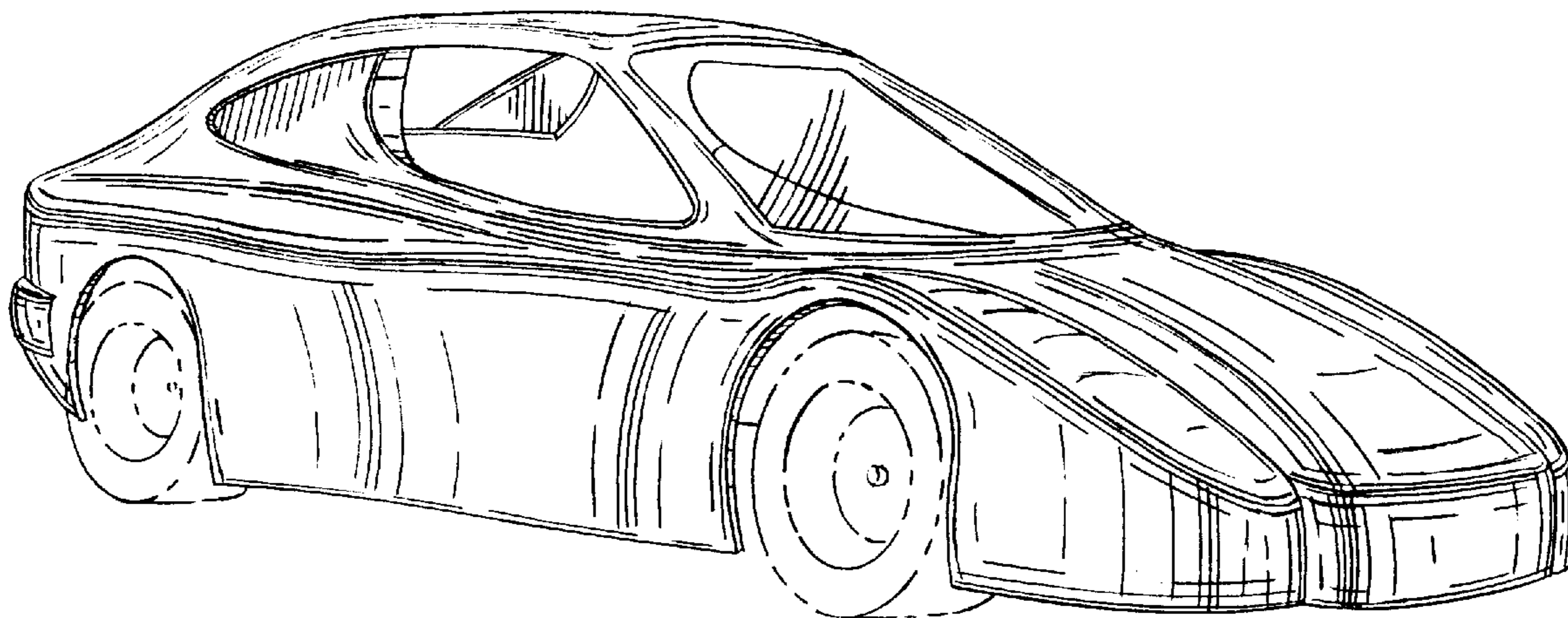

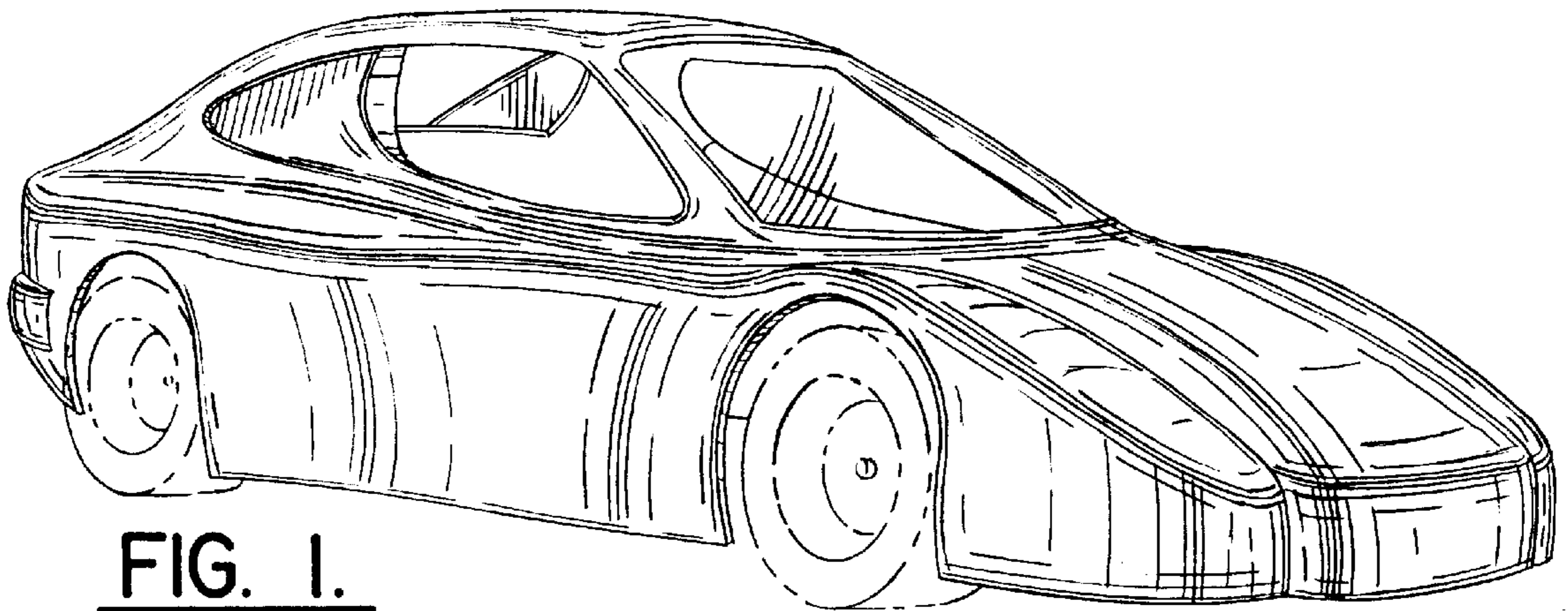

FIG. 1.

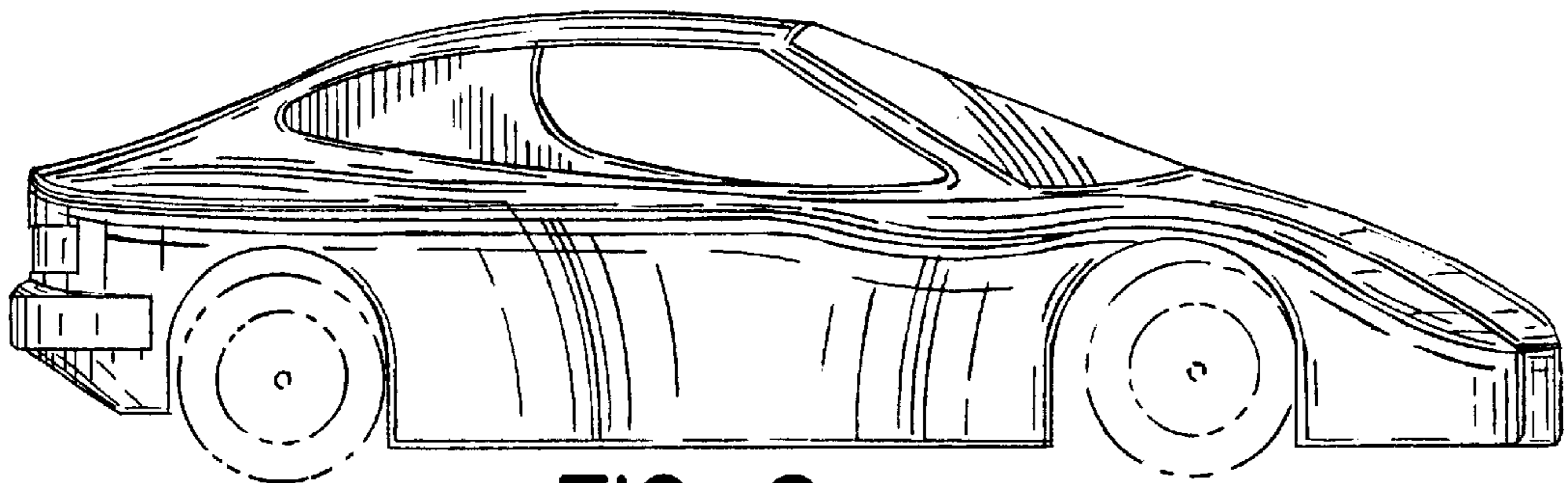

FIG. 2.

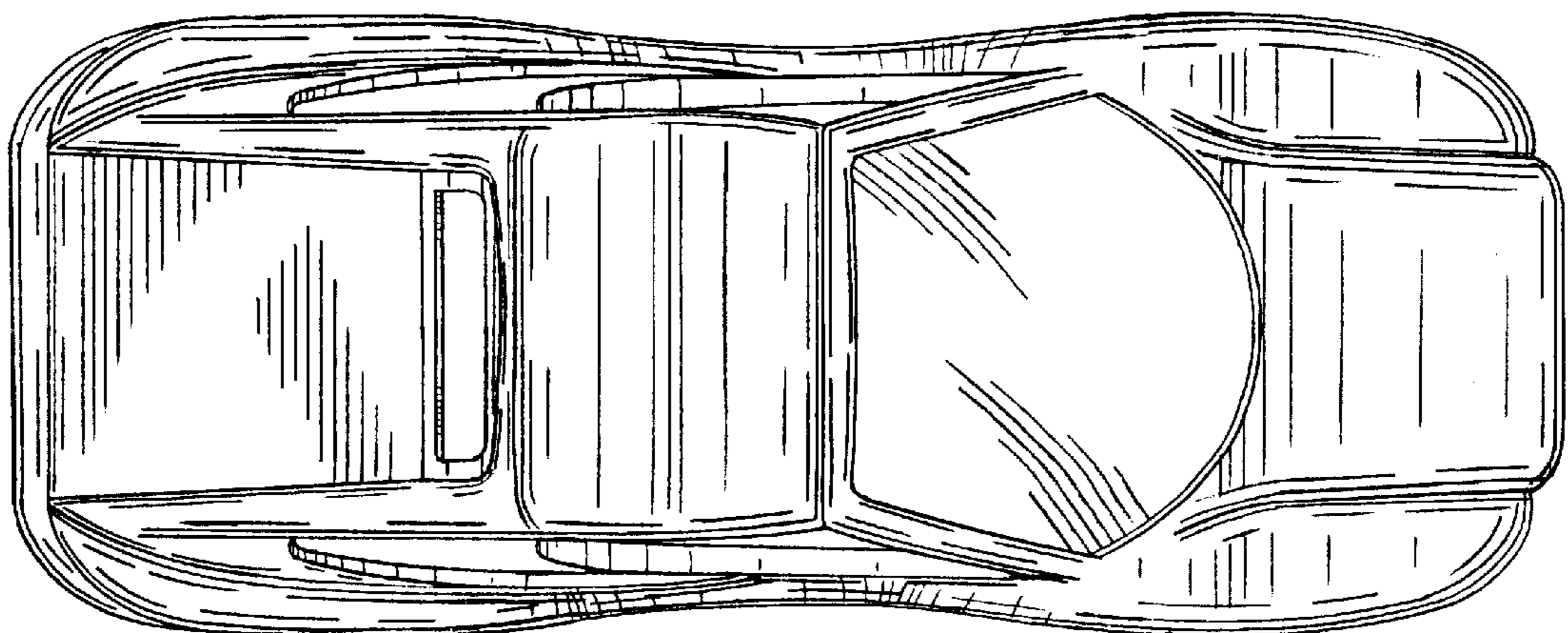

FIG. 3.

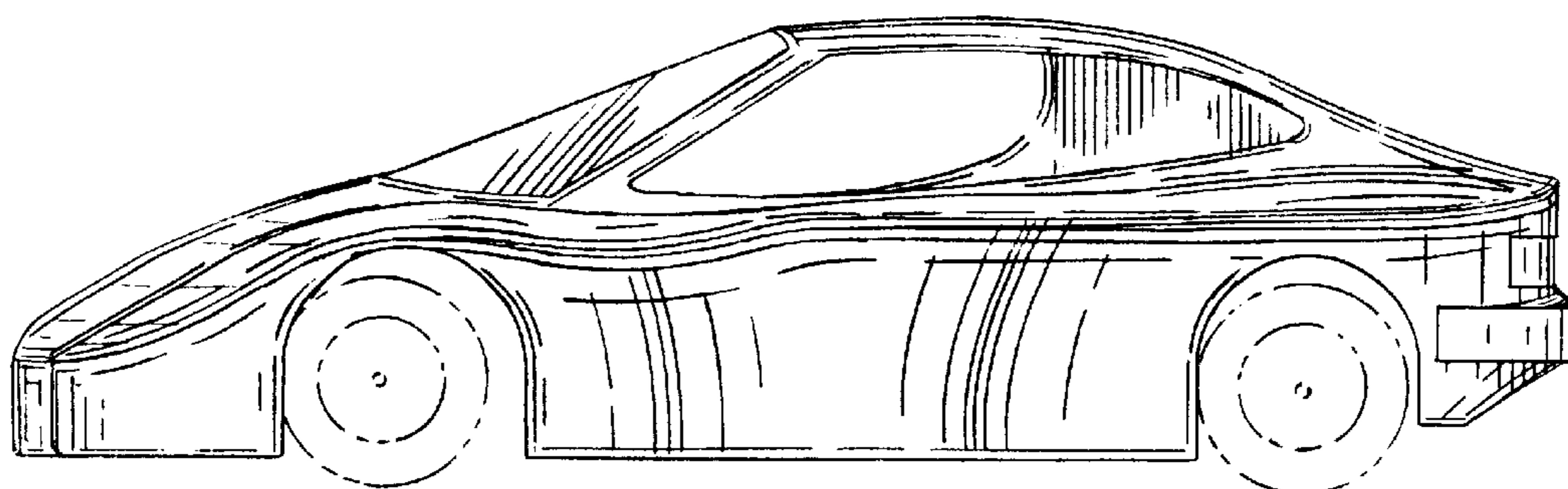

FIG. 4.

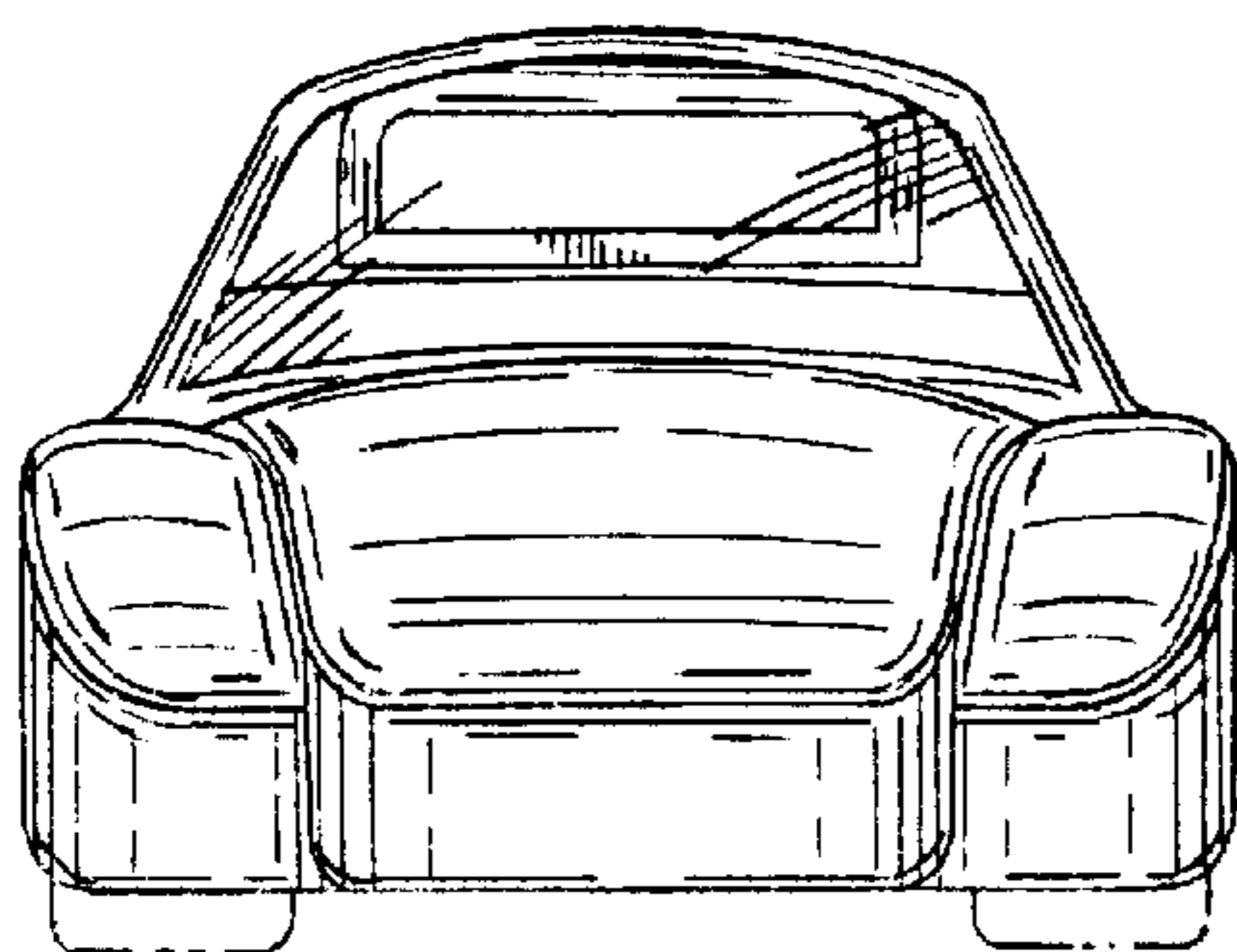

FIG. 5.

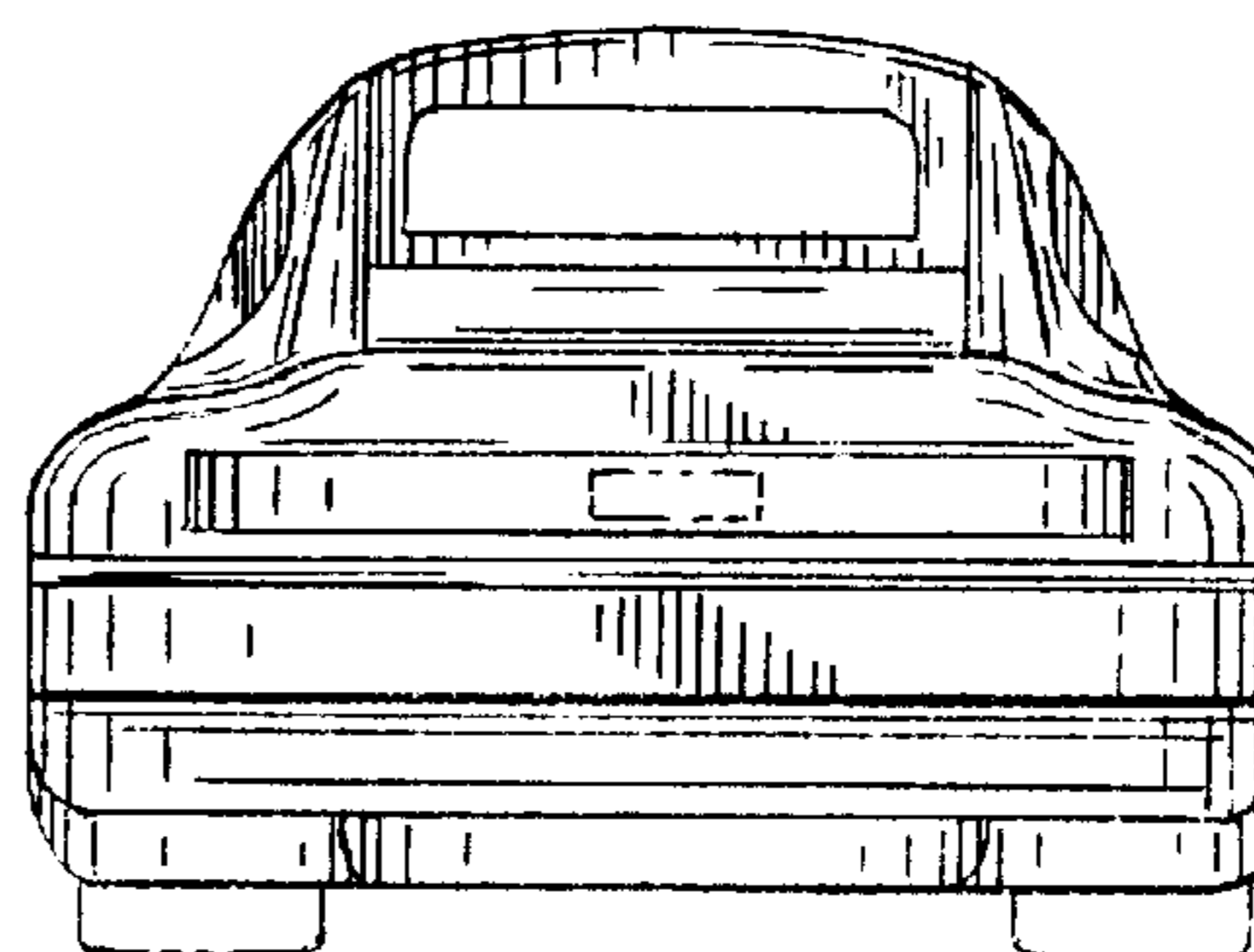

FIG. 6.

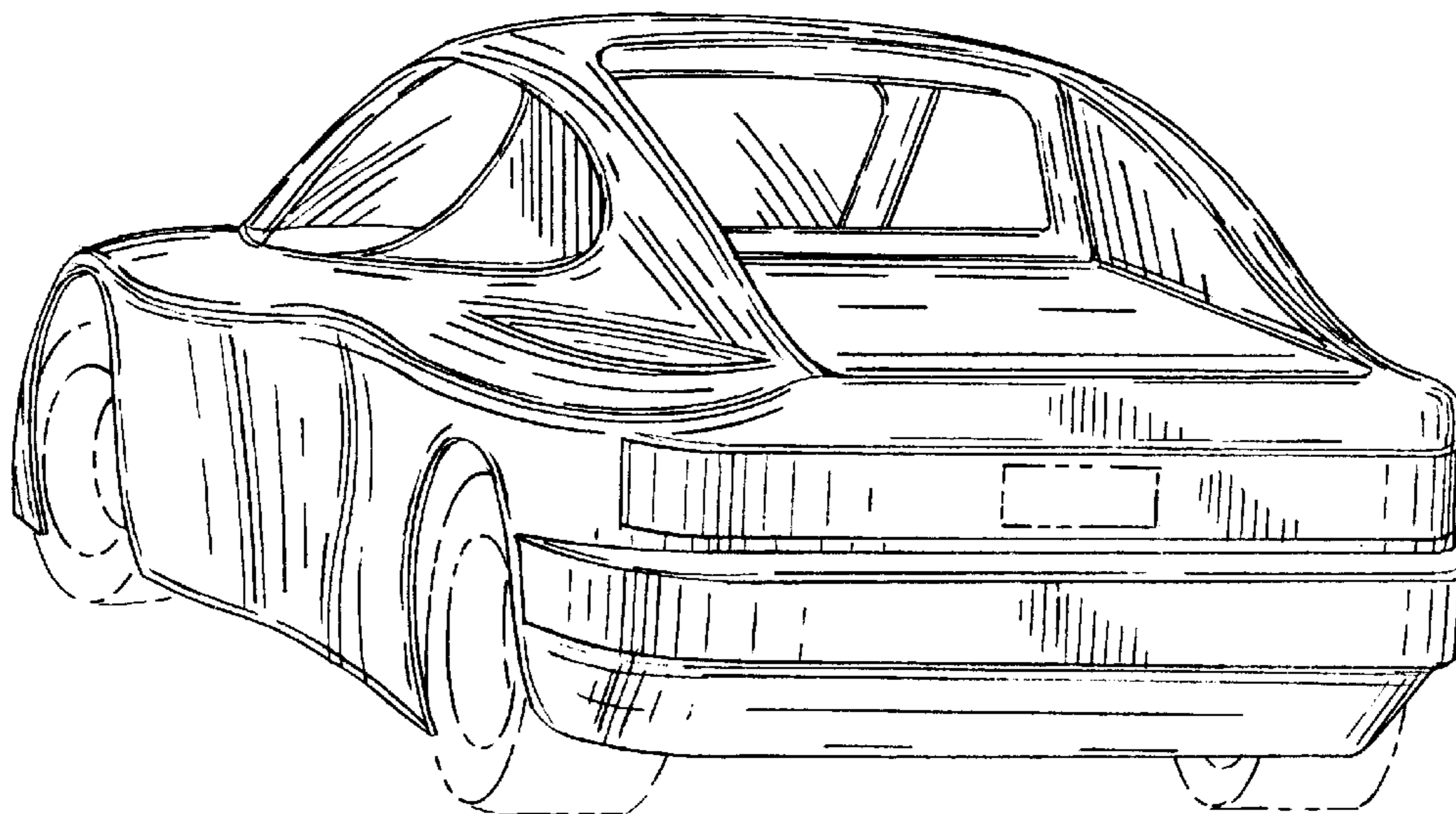

FIG. 7.