



US00D421118S

United States Patent [19]

[11] **Patent Number: Des. 421,118**

Reischel et al.

[45] **Date of Patent: ** Feb. 22, 2000**

[54] **INLET PORT ADAPTOR ON A FULL-FACE RESPIRATOR LENS**

[75] Inventors: **Joseph G. Reischel**, Woodbury; **Frank J. Fabin**, Eagan; **Michael J. Bartholomew**, Lake Elmo; **David P. Knivslund**, North St. Paul, all of Minn.

[73] Assignee: **3M Innovative Properties Company**, St. Paul, Minn.

[**] Term: **14 Years**

[21] Appl. No.: **29/090,934**

[22] Filed: **Jul. 20, 1998**

[51] **LOC (7) Cl.** **29-02**

[52] **U.S. Cl.** **D24/110.6; D24/110; D24/110.1; D24/110.2**

[58] **Field of Search** D24/110.1, 110, D24/110.2, 110.3, 110.4, 110.5, 110.6; 128/206.17, 206.15, 205.25, 206.12, 201.19, 201.24, 201.21

[56] **References Cited**

U.S. PATENT DOCUMENTS

D. 378,610	3/1997	Reischel et al.	D24/110.1
5,224,474	7/1993	Bloomfield	128/201.19
5,924,420	7/1999	Reischel et al.	128/206.21

OTHER PUBLICATIONS

Pro-Tech Cosmo™ product literature (May 1997).
Wilson Safety Products 6000 Series Supplied Air Line product literature.
North Chemical Protection product literature.

Kasco Venus product literature.
Survivair Air Purifying Respirators product literature.
LifeAir™ 1500 product literature.
Cabot Safety AOSafety™ Respiratory Products product literature.
3M™ Continuous Flow Systems Matrix product literature (Jun. 1998).
ISI Asbestos Respiratory Protection product literature.
Omnistar™ Respirator System product literature.

Primary Examiner—Stella Reid
Assistant Examiner—I Simmons
Attorney, Agent, or Firm—Karl G. Hanson

[57] **CLAIM**

The ornamental design for an inlet port adaptor on a full-face respirator lens, as shown and described.

DESCRIPTION

FIG. 1 is a perspective view of a inlet port adaptor on a full-face respirator lens, showing the new design.
FIG. 2 is a front elevational view thereof.
FIG. 3 is a rear elevational view thereof.
FIG. 4 is a right-side elevational view thereof. The left-side elevational view is a mirror image of the right-side elevational view.
FIG. 5 is a bottom plan view thereof; and,
FIG. 6 is a top plan view thereof.
The broken lines form no part of the claimed design other than to illustrate the orientation of the inlet port adaptor on a full-face respirator lens. The shading provided in the drawings is furnished merely to indicate contour; it is not indicative of any particular texture.

1 Claim, 5 Drawing Sheets

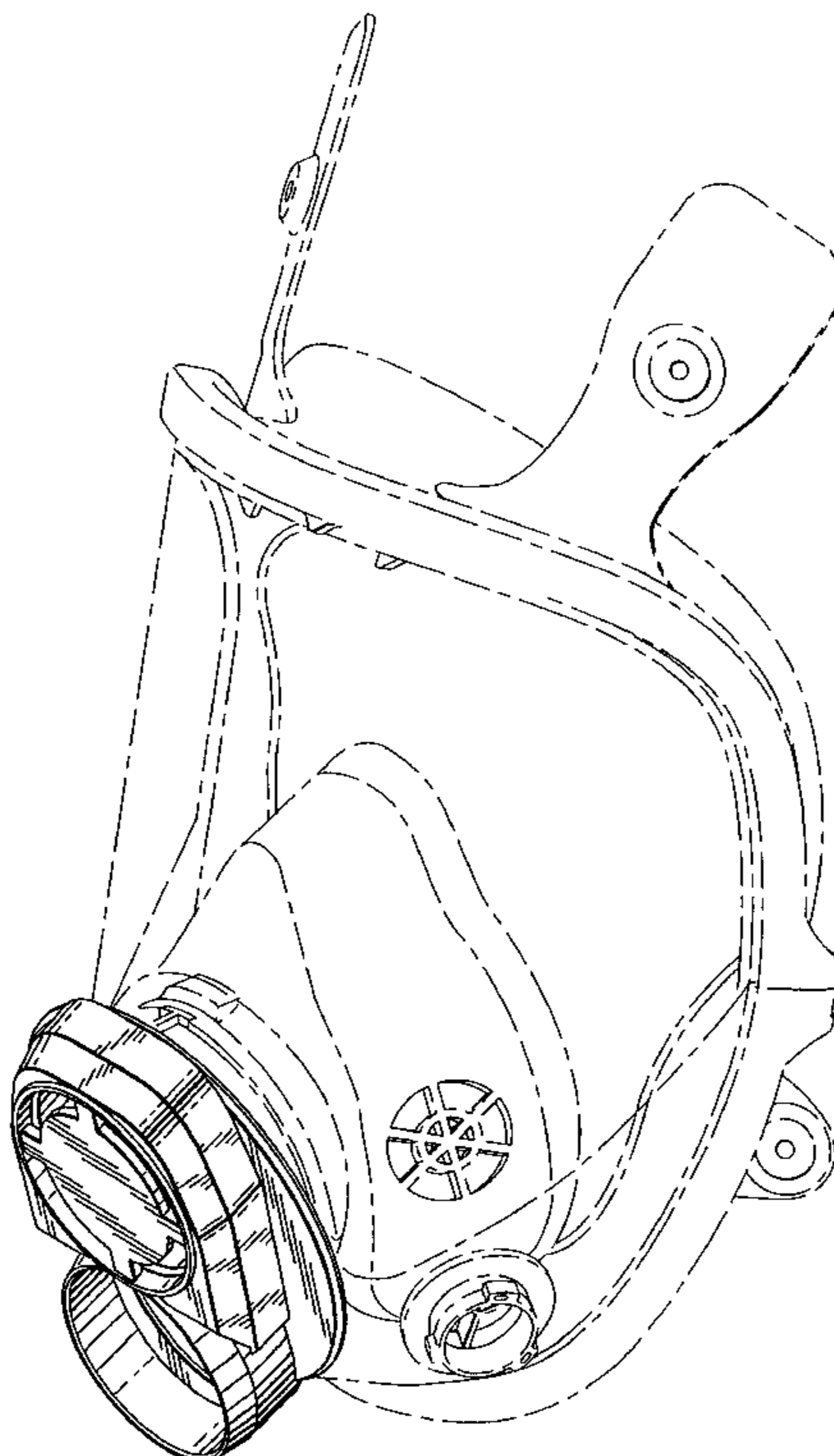

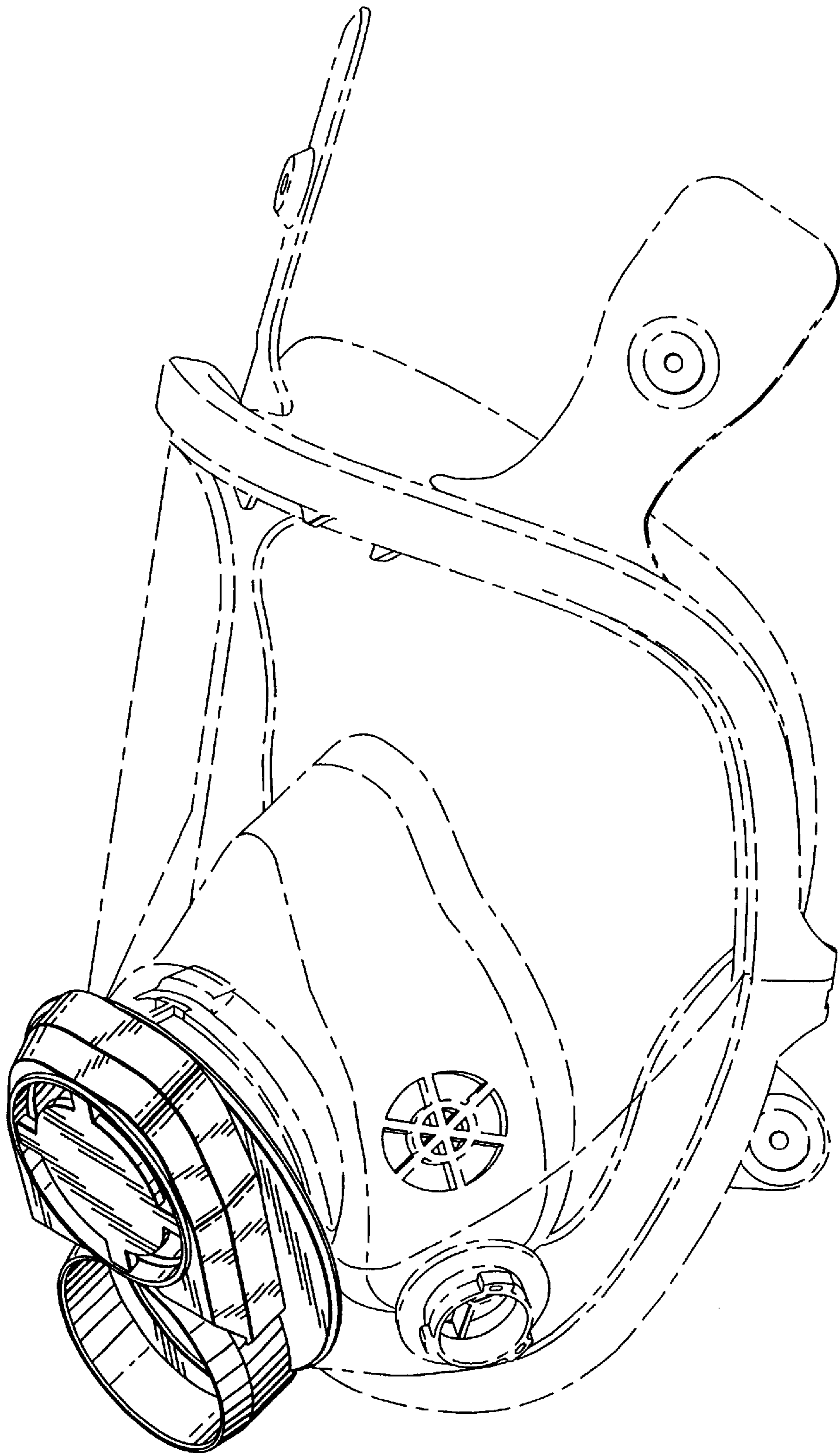

Fig. 1

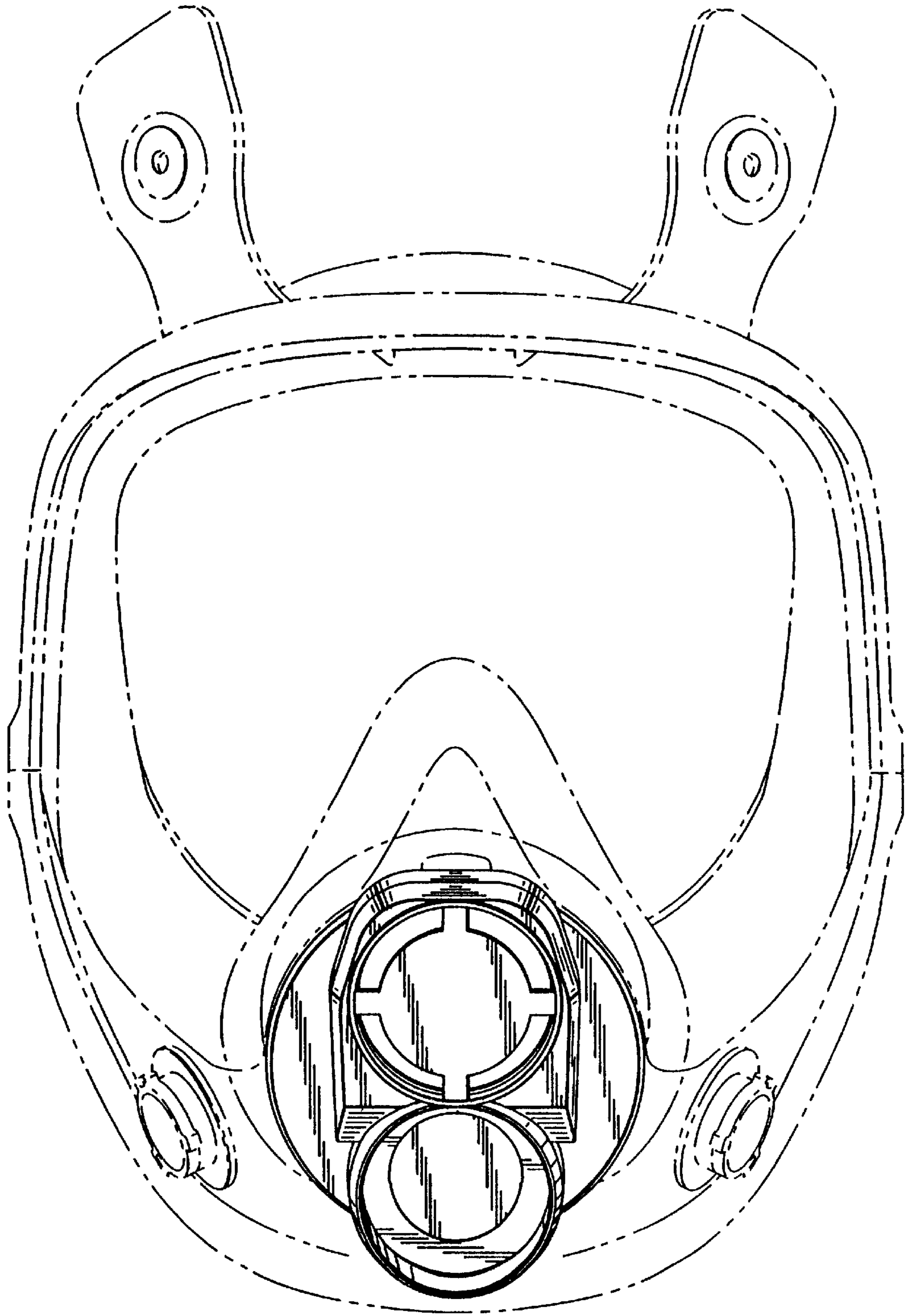

Fig. 2

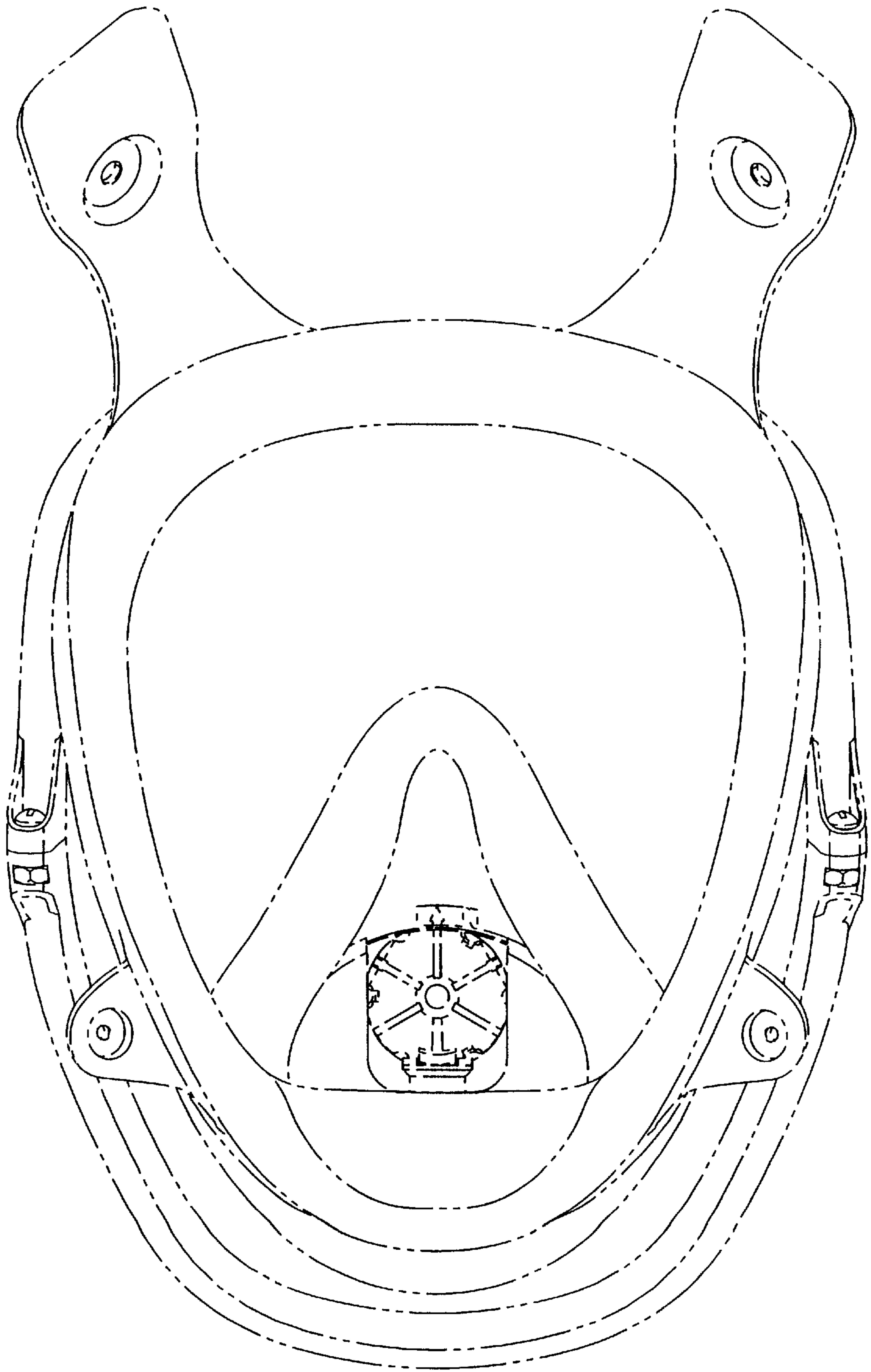

Fig. 3

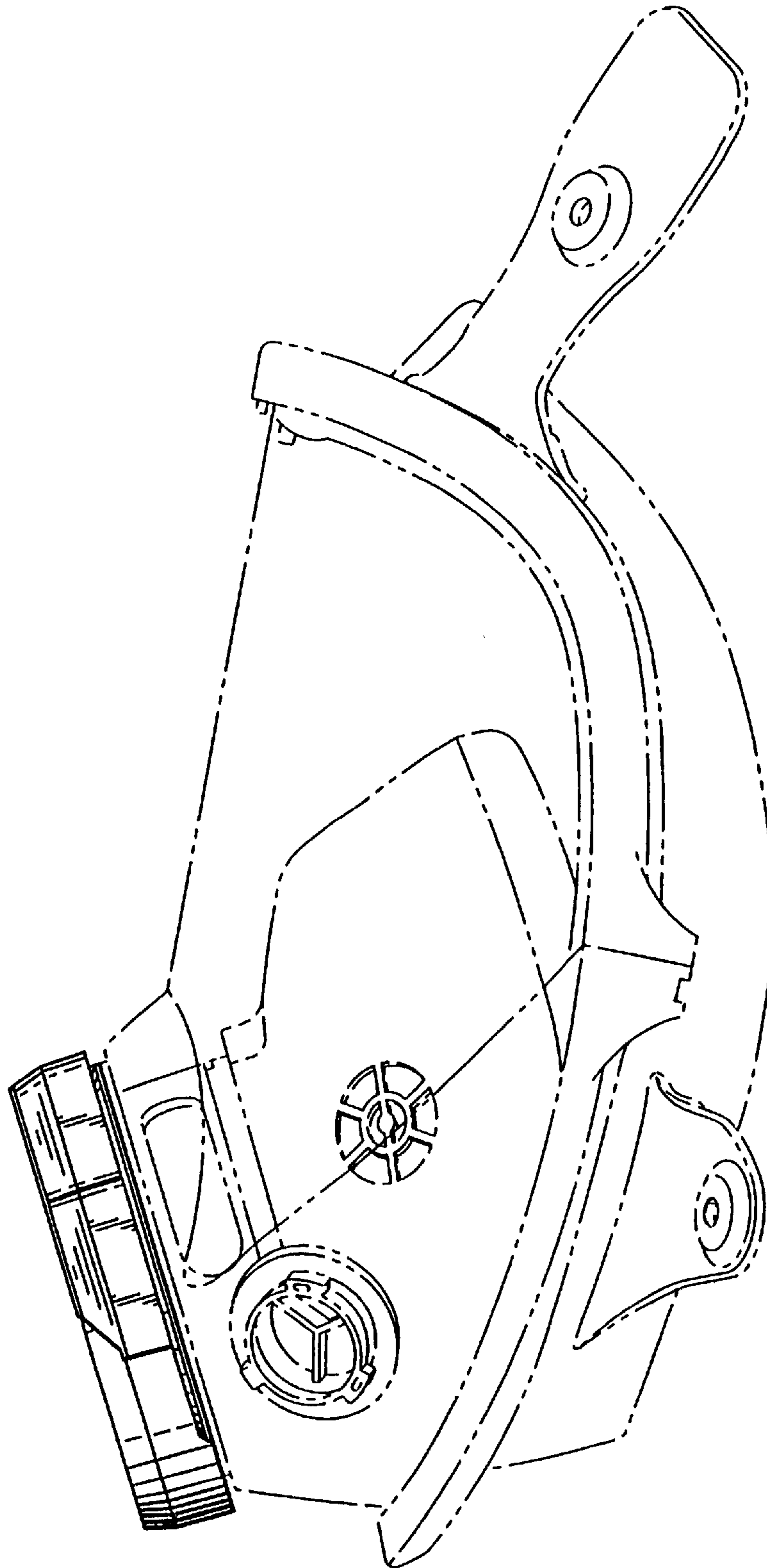

Fig. 4

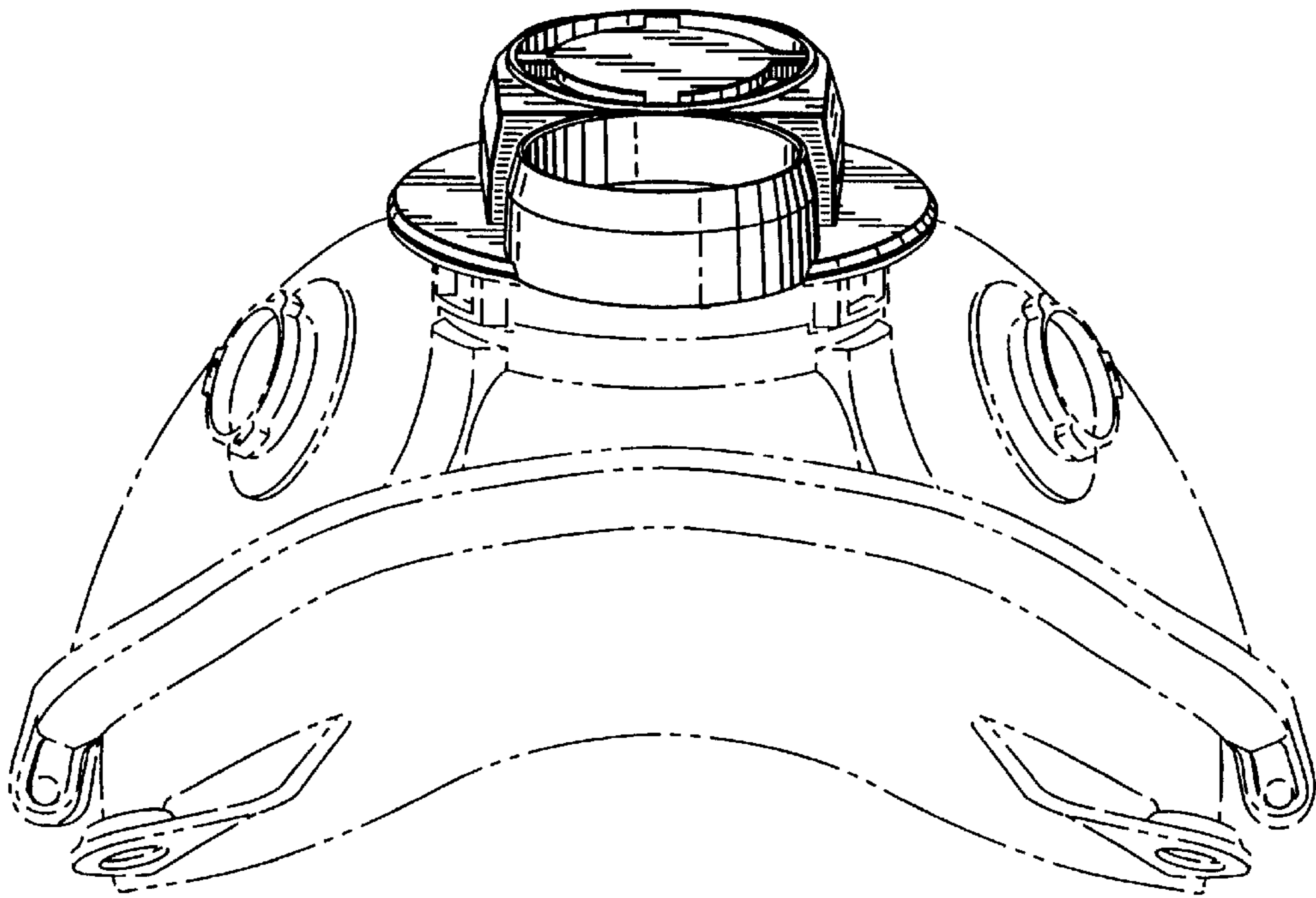

Fig. 5

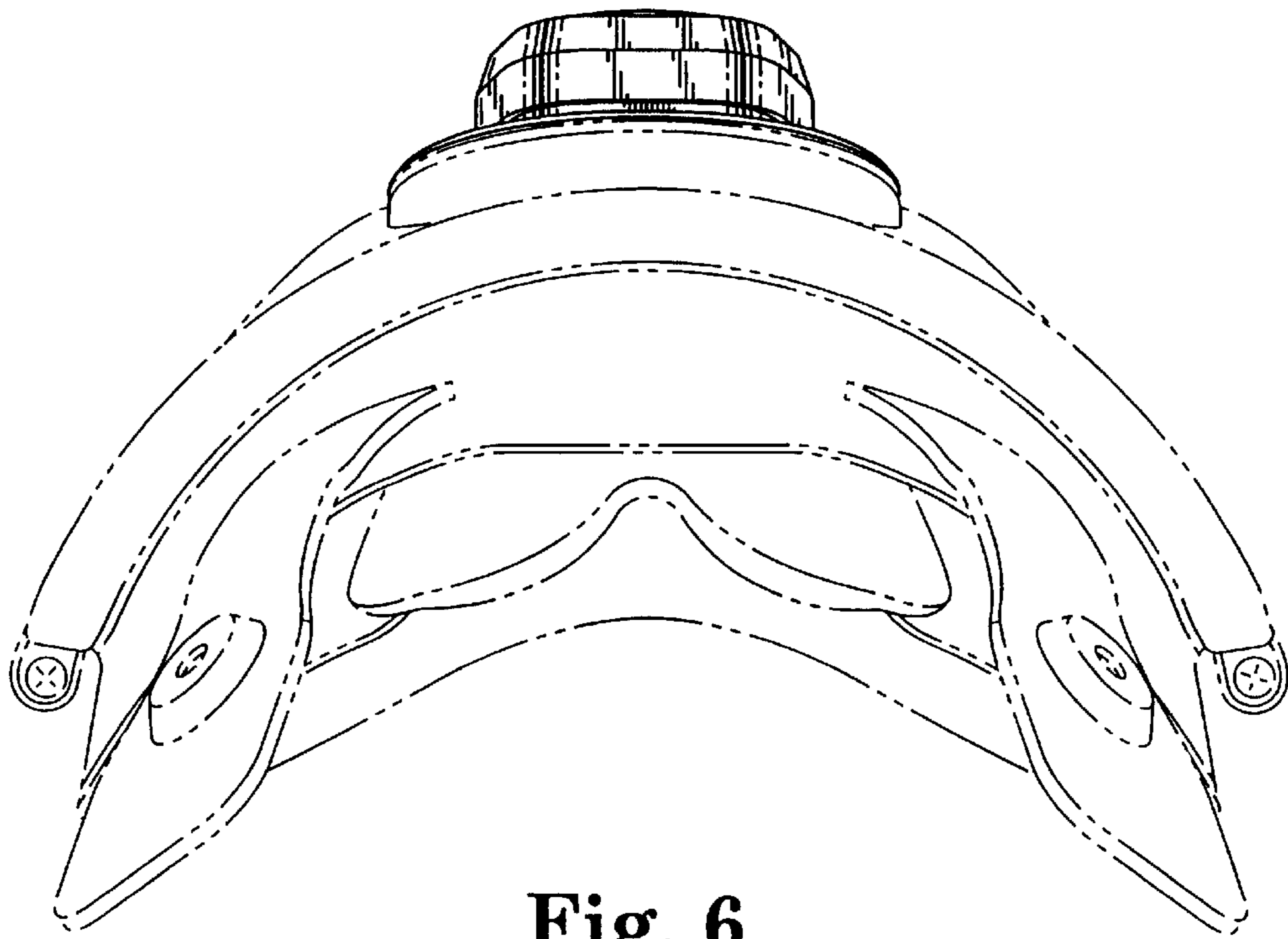

Fig. 6