



US00D421058S

# United States Patent [19]

[11] **Patent Number: Des. 421,058**

**Regan et al.**

[45] **Date of Patent: \*\* Feb. 22, 2000**

[54] **ADHESIVE DISPENSER**

[75] Inventors: **Philip Malcom Regan**, Naas, Ireland;  
**Stephan Blom**, Helmond, Netherlands;  
**Luca Cella**, Milan; **Luigi Vanini**,  
Albizzate, both of Italy

D. 199,606	11/1964	Waterman	.....	D9/338 X
D. 225,154	11/1972	Singer	.....	D9/533
D. 248,865	8/1978	Sussman et al.	.....	D19/43
D. 338,159	8/1993	Densky et al.	.....	D9/574
D. 348,611	7/1994	Abfier et al.	.....	D9/529
D. 353,099	12/1994	Poisson	.....	D9/542
2,865,384	12/1958	Noon	.....	401/129 X

[73] Assignee: **Henkel Kommanditgesellschaft auf Aktien**, Duesseldorf, Germany

*Primary Examiner*—Martie K. Holtje  
*Attorney, Agent, or Firm*—Ernest G. Szoke; Wayne C. Jaeschke; Kenneth Watov

[\*\*] Term: **14 Years**

[21] Appl. No.: **29/098,311**

[57] **CLAIM**

[22] Filed: **Dec. 23, 1998**

The ornamental design for adhesive dispenser, as shown and described.

[30] **Foreign Application Priority Data**

**DESCRIPTION**

Jun. 30, 1998 [GB] United Kingdom ..... 2075661

[51] **LOC (7) Cl.** ..... **19-02**

[52] **U.S. Cl.** ..... **D19/66; D9/570; D9/453; D19/57**

[58] **Field of Search** ..... D9/542, 338, 453, D9/533, 529, 570, 574; D19/35, 36, 65, 66, 48, 43, 49, 51, 57; 401/260–266, 202, 129; 222/210, 212, 519

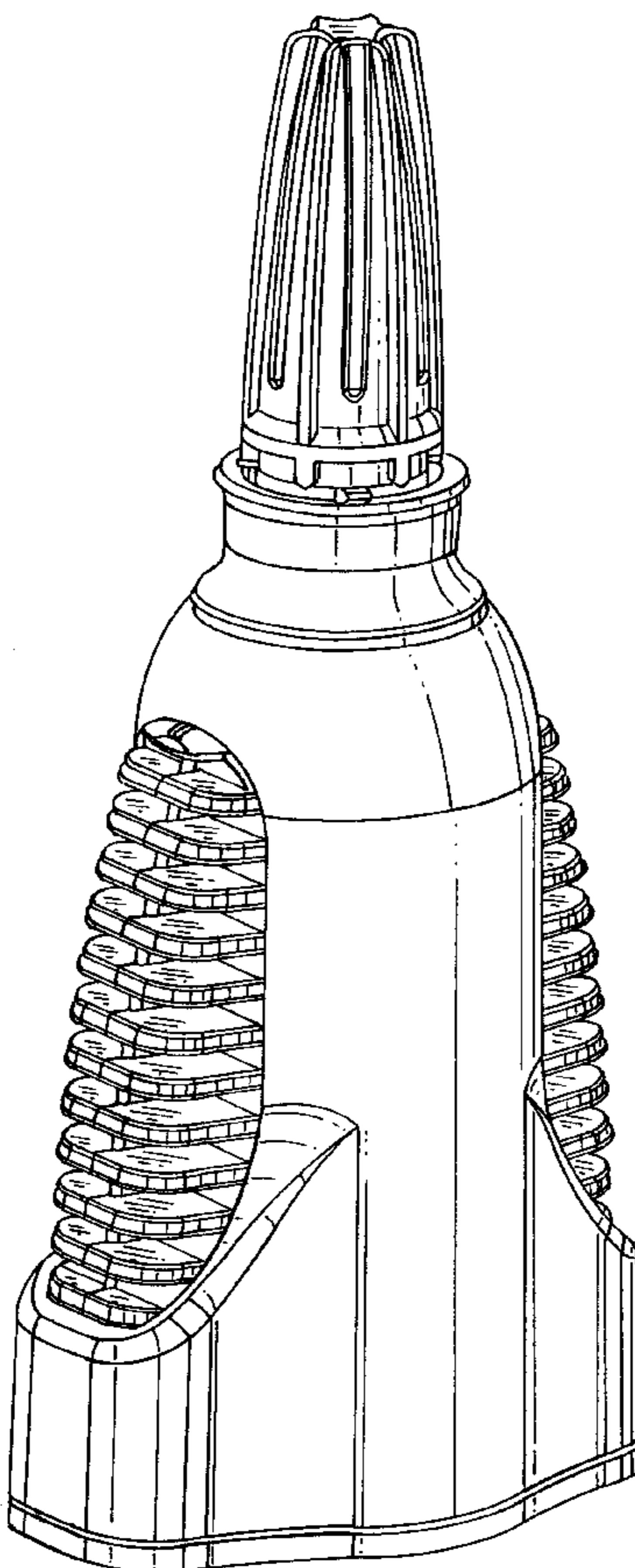
FIG. 1 is a perspective view of the adhesive dispenser showing our new design;  
FIG. 2 is a front elevational view thereof, whereby the rear elevational view thereof is identical thereto;  
FIG. 3 is a left side elevational view thereof, whereby the right side elevational view is identical thereto;  
FIG. 4 is an enlarged top plan view thereof; and,  
FIG. 5 is a bottom plan view thereof.

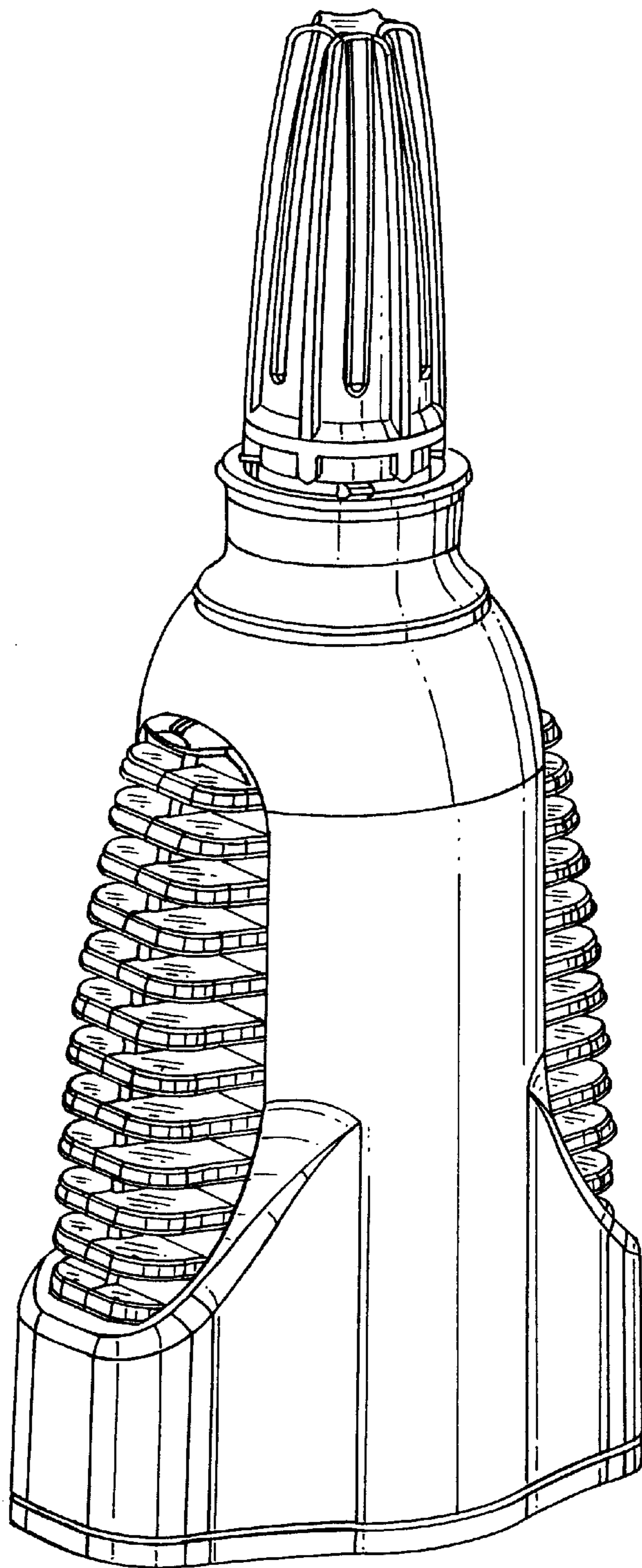
[56] **References Cited**

**U.S. PATENT DOCUMENTS**

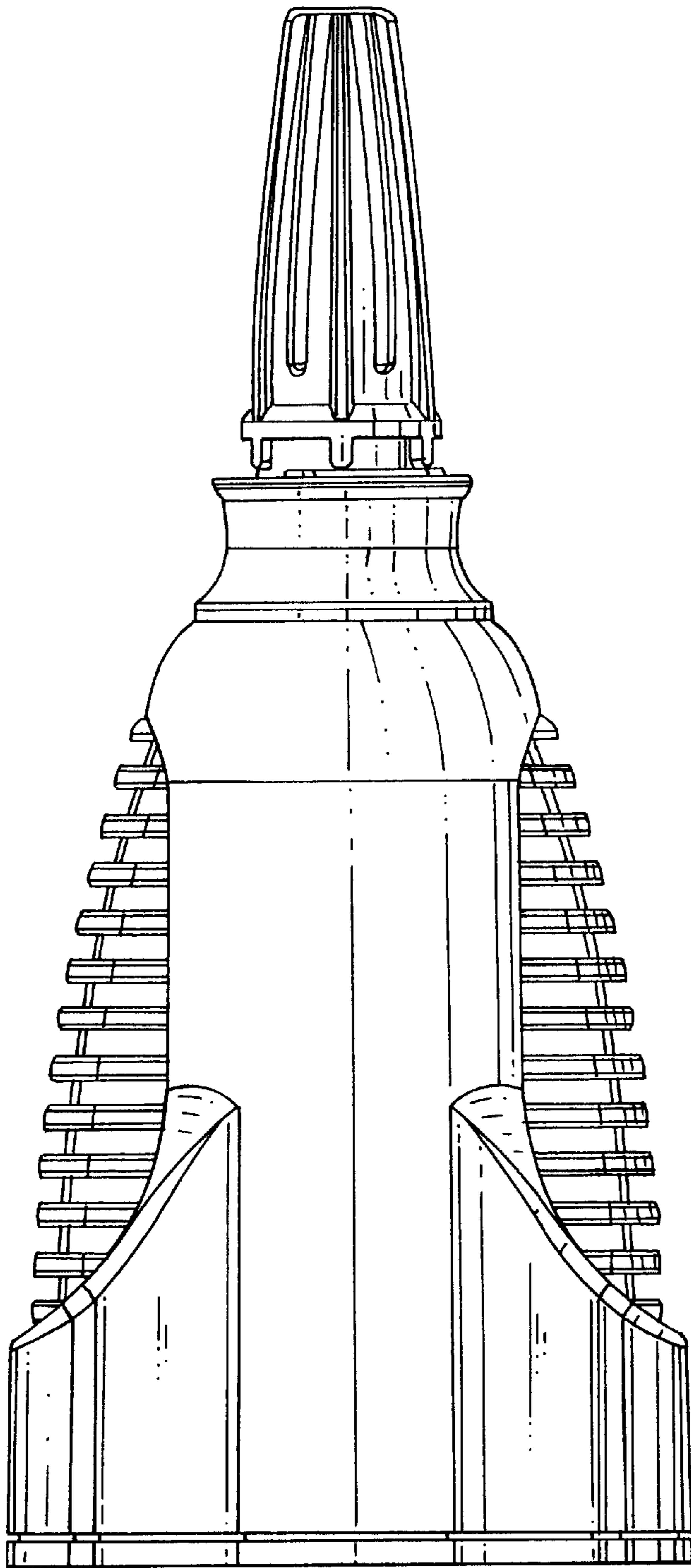
D. 123,502 11/1940 Jung ..... D9/453

**1 Claim, 5 Drawing Sheets**

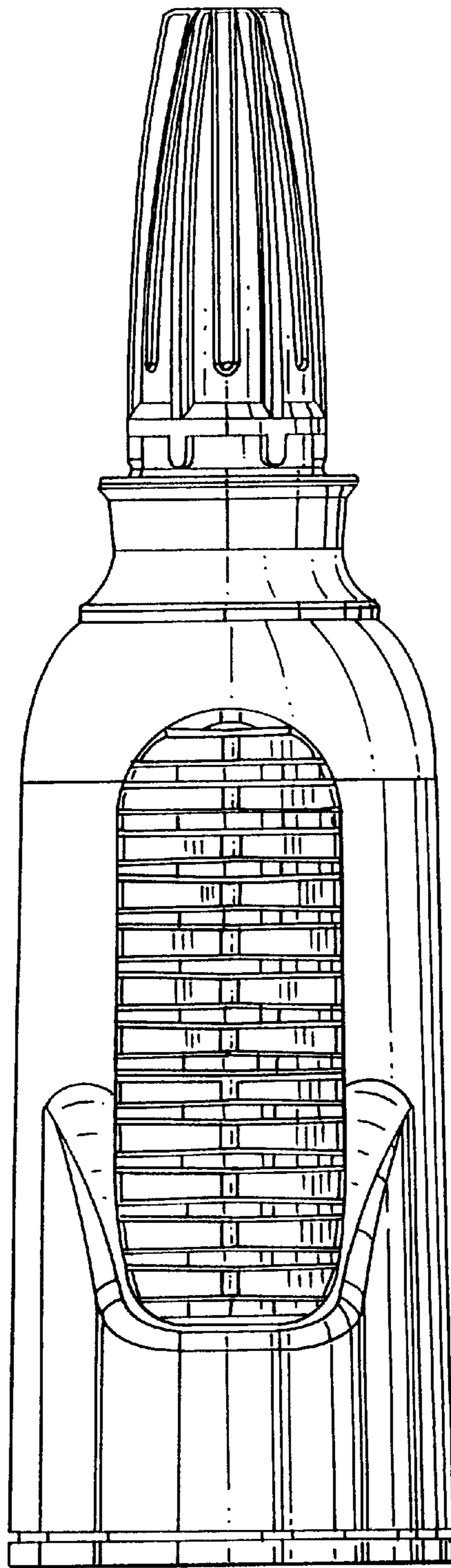




**FIG. 1**

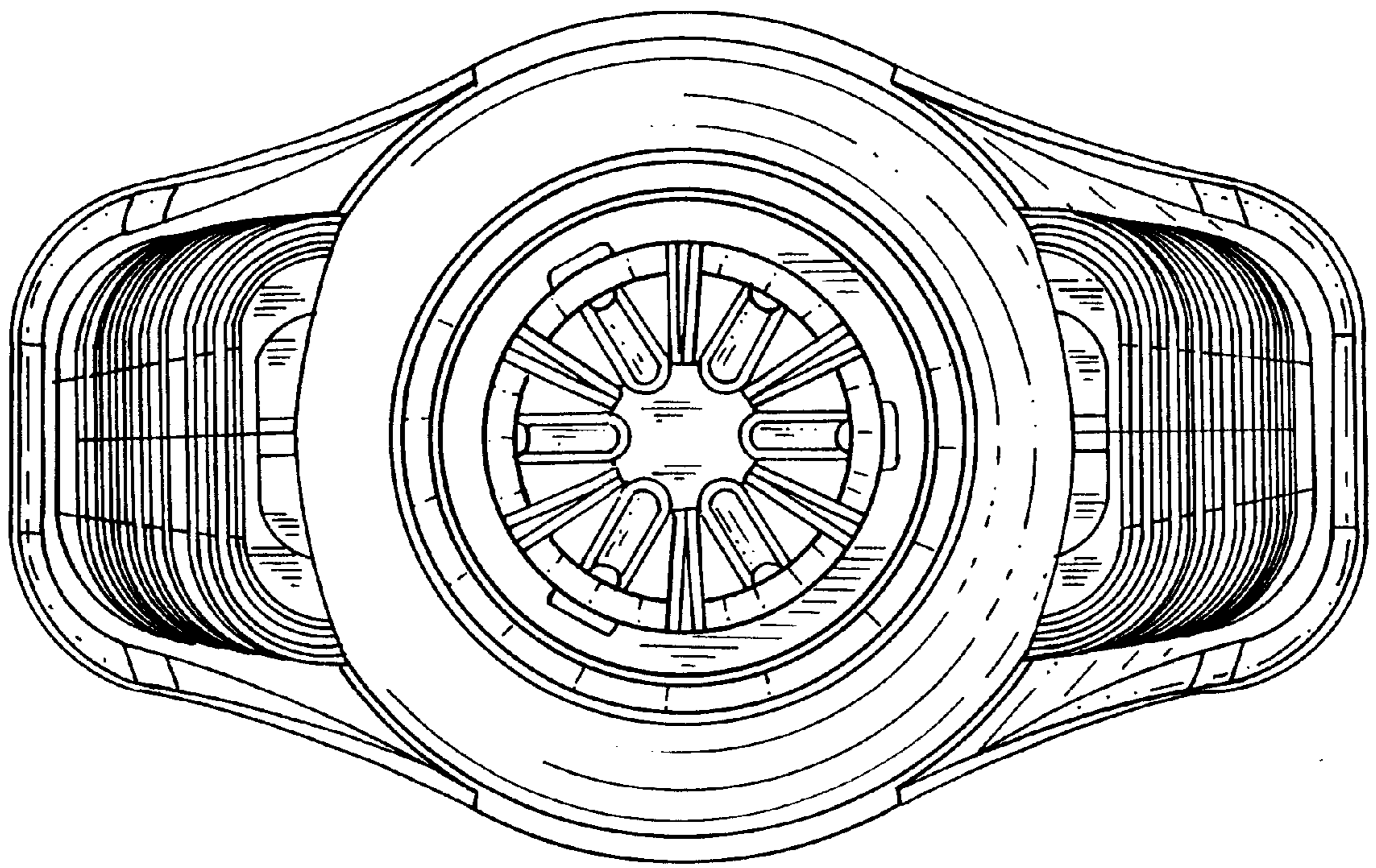


*FIG. 2*

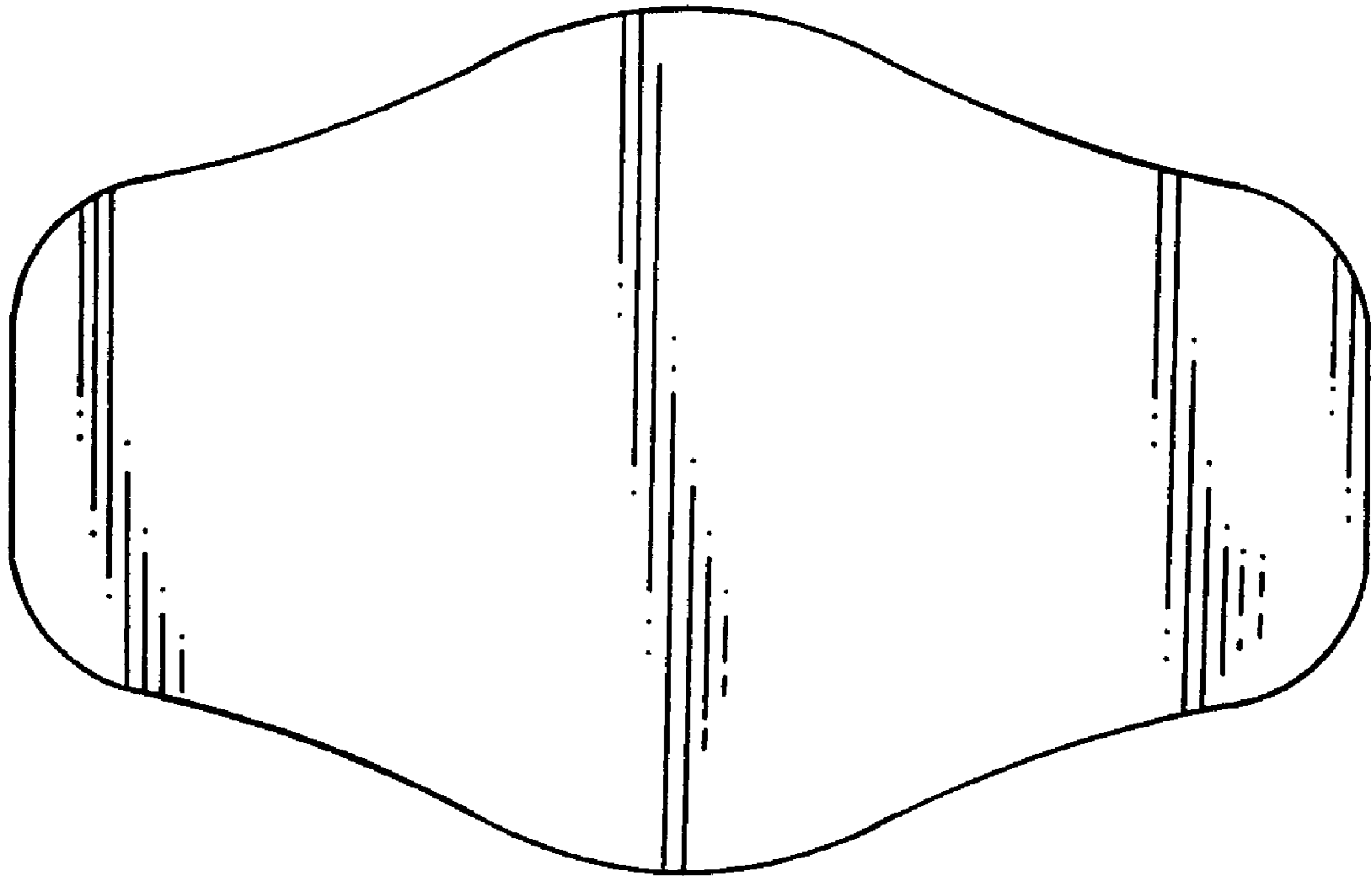


*FIG. 3*





**FIG. 4**



**FIG. 5**