



US00D420971S

# United States Patent [19]

Sacco et al.

[11] Patent Number: **Des. 420,971**

[45] Date of Patent: **\*\* Feb. 22, 2000**

[54] **MIRRORED COMPARTMENT FOR A VEHICLE**

[75] Inventors: **Bruno Sacco; Harald Leschke**, both of Sindelfingen, Germany; **Olivier Boulay**, Tokyo; **Shuichi Yamashita**, Yokohama; **Anthony Lo**, Tokyo, all of Japan

[73] Assignee: **DaimlerChrysler AG**, Germany

[\*\*] Term: **14 Years**

[21] Appl. No.: **29/092,457**

[22] Filed: **Aug. 19, 1998**

[51] **LOC (7) Cl.** ..... **12-16**

[52] **U.S. Cl.** ..... **D12/416**

[58] **Field of Search** ..... D12/423-425, D12/415, 416, 421, 426, 400; 296/37.1, 37.6, 37.8-37.15, 37.16; 224/42.11, 42.24, 42.25, 275, 400, 539-543; D3/901, 903, 293

[56] **References Cited**

**U.S. PATENT DOCUMENTS**

D. 99,413	4/1936	O'Neill	.....	D12/423
D. 163,587	6/1951	Eddleman et al.	.....	D12/423
D. 257,800	1/1981	Pederson	.....	D3/901 X
D. 259,154	5/1981	White, Jr. et al.	.....	D3/901 X
D. 269,735	7/1983	Bunetta	.....	D3/901 X
D. 285,998	10/1986	Langensiepen	.....	D12/423
D. 290,189	6/1987	Sakai	.....	D12/423
D. 309,829	8/1990	Charet et al.	.....	D3/901 X

D. 355,072	2/1995	Tiramani	.....	D3/901
D. 373,754	9/1996	Pinterpe	.....	D12/424
D. 374,423	10/1996	Downey, II et al.	.....	D12/423
D. 411,980	7/1999	Sacco et al.	.....	D12/425

*Primary Examiner*—Doris V. Coles  
*Assistant Examiner*—Stacia Cadmus  
*Attorney, Agent, or Firm*—Evenson, McKeown, Edwards & Lenahan, P.L.L.C.

[57] **CLAIM**

The ornamental design for a mirrored compartment for a vehicle, as shown and described.

**DESCRIPTION**

FIG. 1 is a front view of a mirrored compartment for a vehicle according to our novel design;

FIG. 2 is a perspective view from the front right of a mirrored compartment for a vehicle to our novel design, showing the first moveable internal component in an open position, the perspective view from the front left being mirror symmetrical; and,

FIG. 3 is a perspective view from the front right of a mirrored compartment for a vehicle according to our novel design, showing the first and second moveable internal components in an open position, the perspective view from the front left being mirror symmetrical.

The bottom of the compartment is attached directly to the housing and is not part of the claimed design. Also, the dash line included depicts environment and is not part of the claimed design.

**1 Claim, 3 Drawing Sheets**

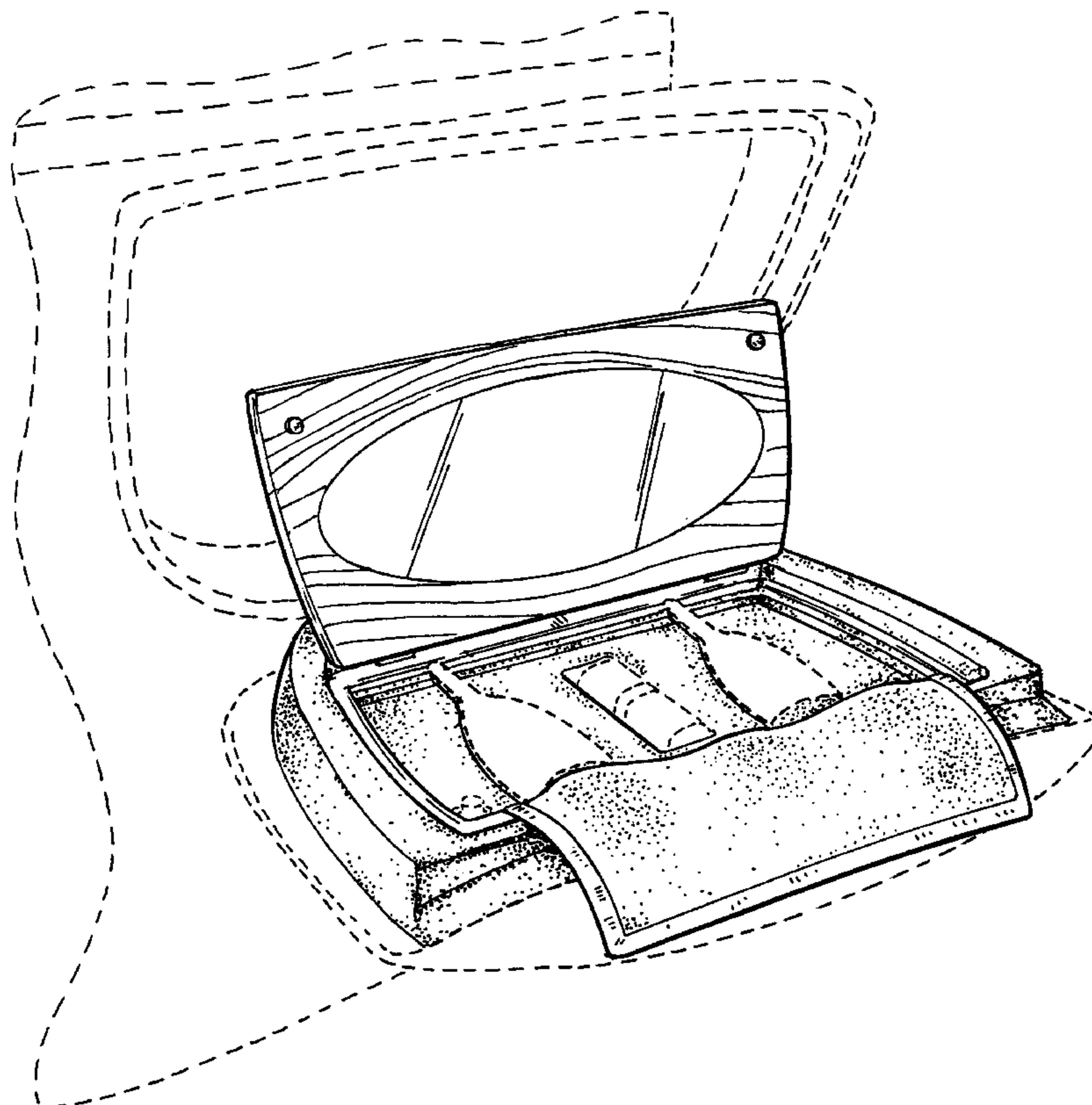

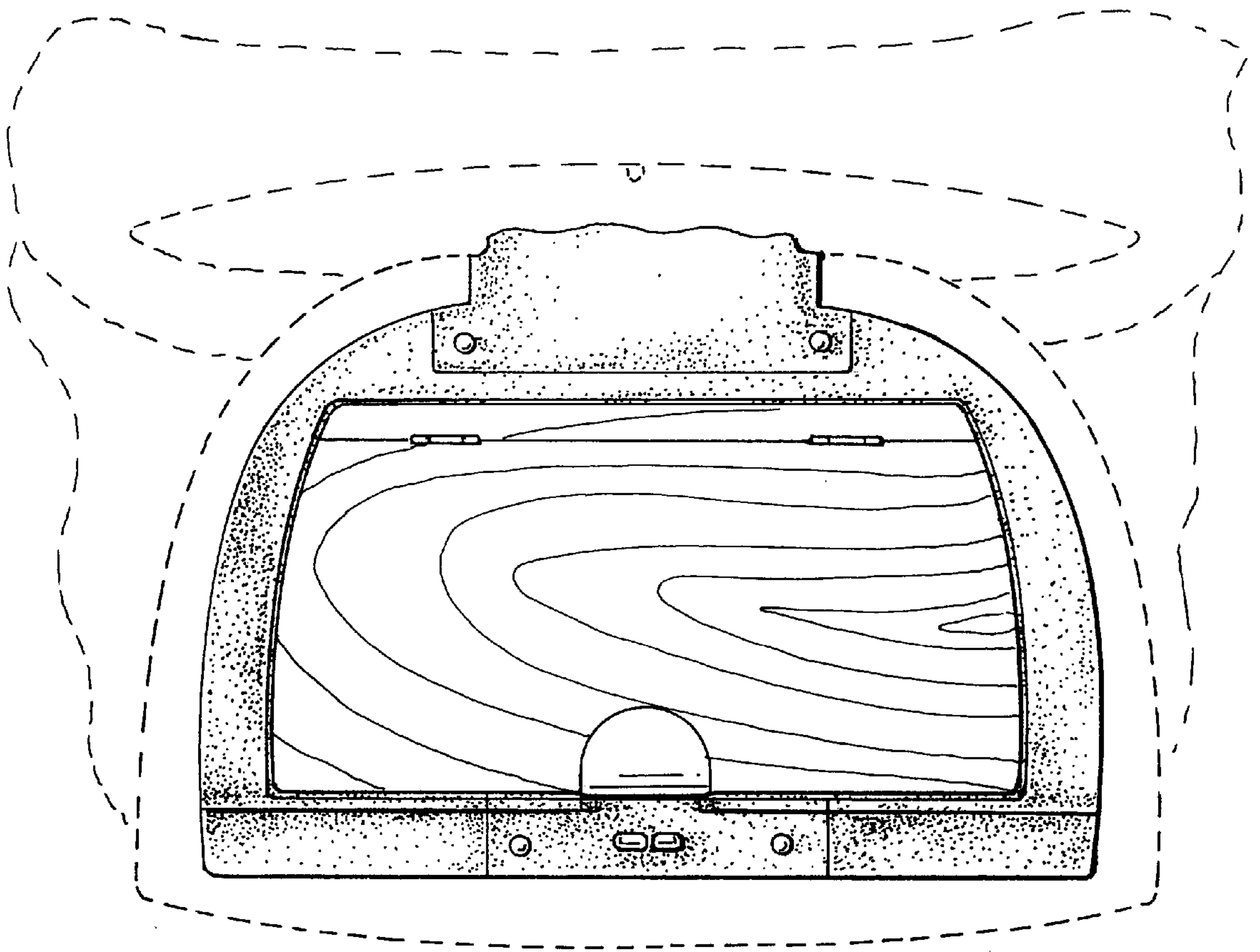

FIG. 1

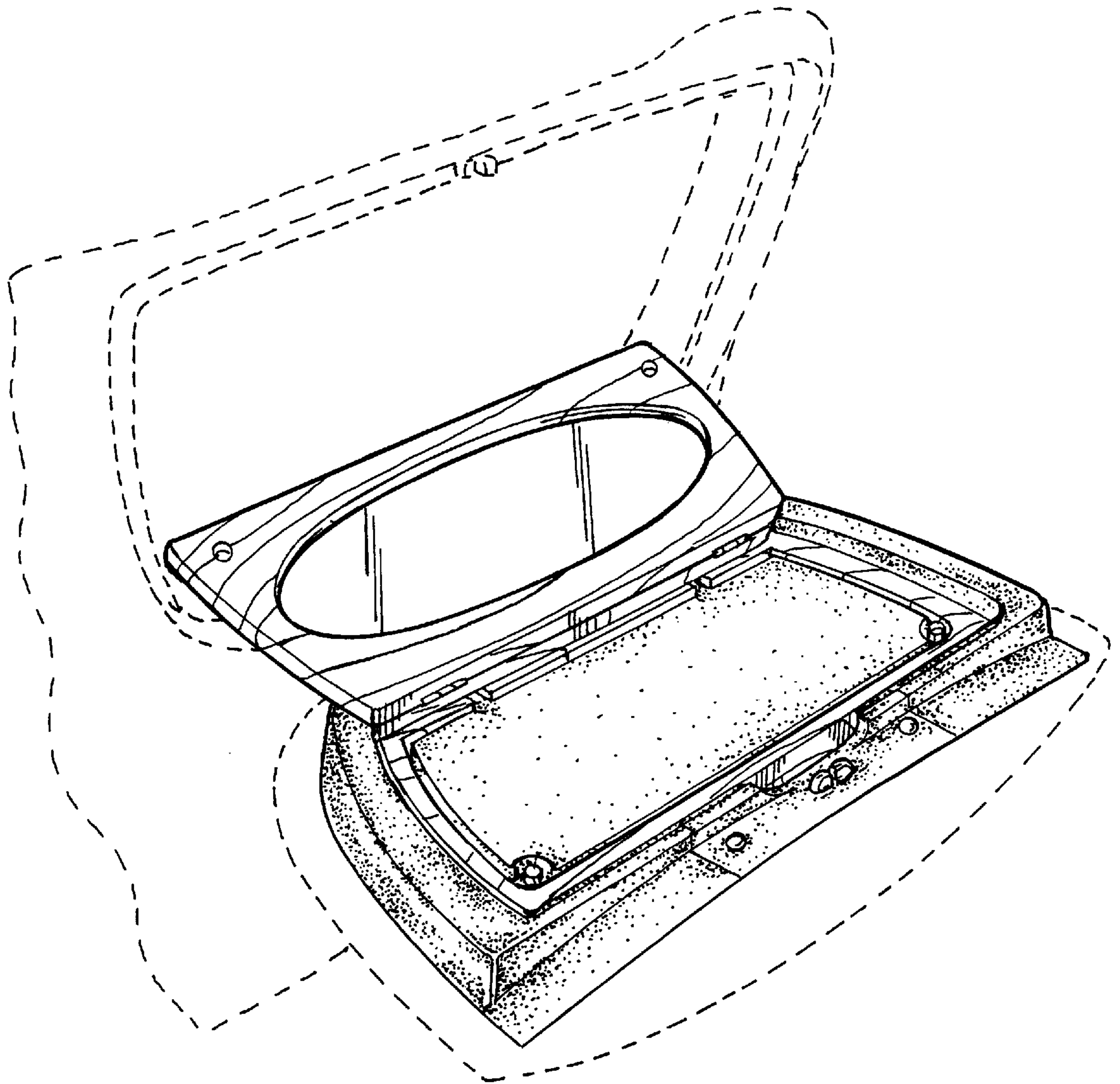

FIG. 2



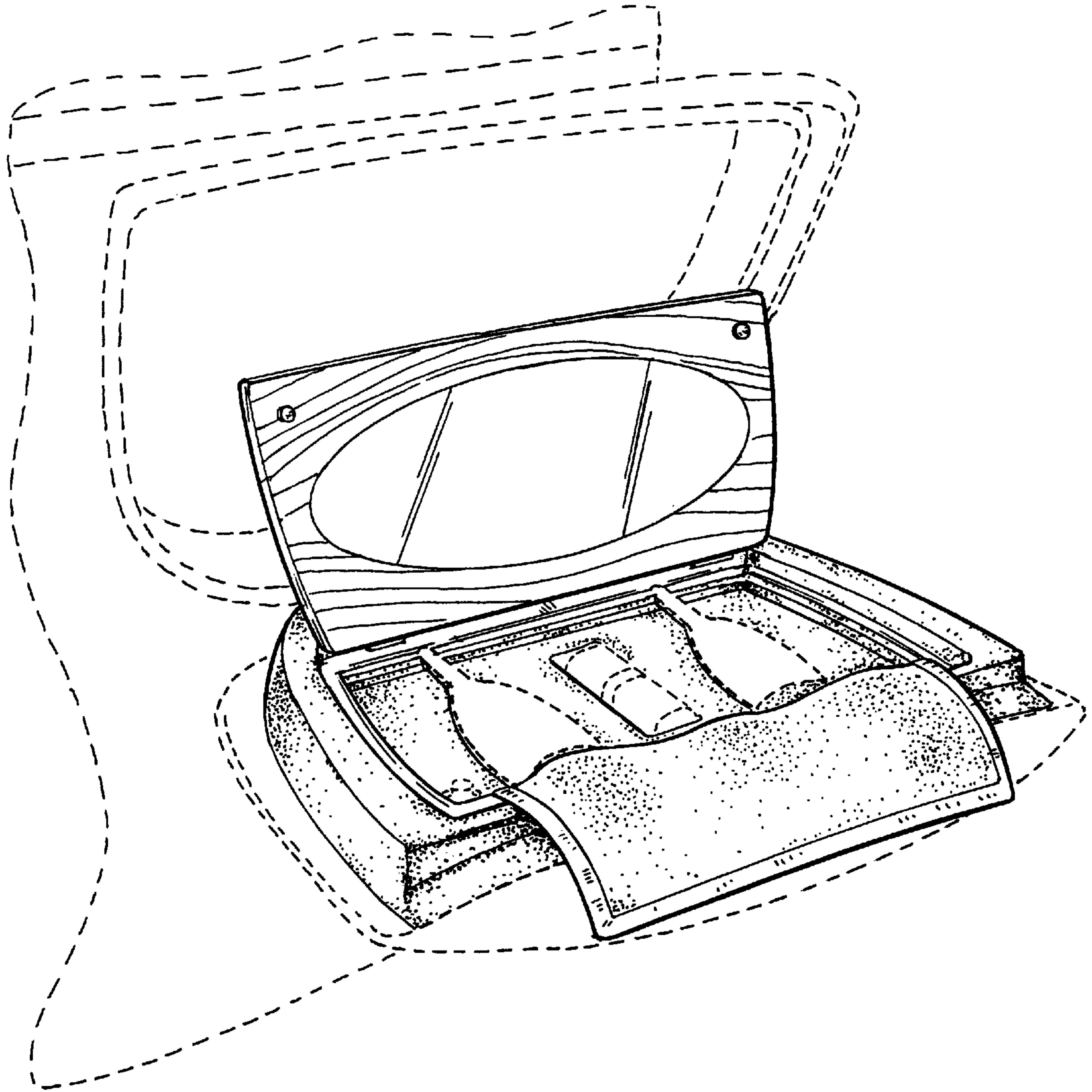

FIG. 3