



US00D420963S

United States Patent [19]

[11] **Patent Number: Des. 420,963**

Conterno

[45] **Date of Patent: ** Feb. 22, 2000**

[54] **STEERING WHEEL FOR MOTOR VEHICLES AND WATERCRAFTS**

4,945,786 8/1990 Goto 74/552
5,031,429 7/1991 Wang 74/552 X
5,305,655 4/1994 Kuga 74/552

[75] Inventor: **Silvia Conterno**, Varese, Italy

Primary Examiner—Melody N. Brown
Attorney, Agent, or Firm—McAulay Nissen Goldberg Kiel & Hand, LLP

[73] Assignee: **Nardi Italia Spa**, Abbiate Guazzone, Italy

[**] Term: **14 Years**

[57] CLAIM

[21] Appl. No.: **29/080,870**

The ornamental design for a steering wheel for motor vehicles and watercrafts, as shown and described.

[22] Filed: **Dec. 18, 1997**

DESCRIPTION

Related U.S. Application Data

[62] Division of application No. 29/042,784, Aug. 17, 1995.

FIG. 1 is a top view of a steering wheel for motor vehicles and watercrafts, showing my new design;

[30] Foreign Application Priority Data

Feb. 17, 1995 [IT] Italy MI9500099

FIG. 2 is a left side view, and the right side view is a mirror image of the left side;

[51] **LOC (7) Cl.** **12-16**

FIG. 3 is a front view;

[52] **U.S. Cl.** **D12/176**

FIG. 4 is a bottom view; and,

[58] **Field of Search** D12/176, 175;
74/552

FIG. 5 is a rear view.

The broken lines shown in FIGS. 2, 3 and 5 are for illustrative purposes only and form on part of the claimed design.

[56] References Cited

U.S. PATENT DOCUMENTS

4,161,892 7/1979 Conterro 74/552

1 Claim, 2 Drawing Sheets

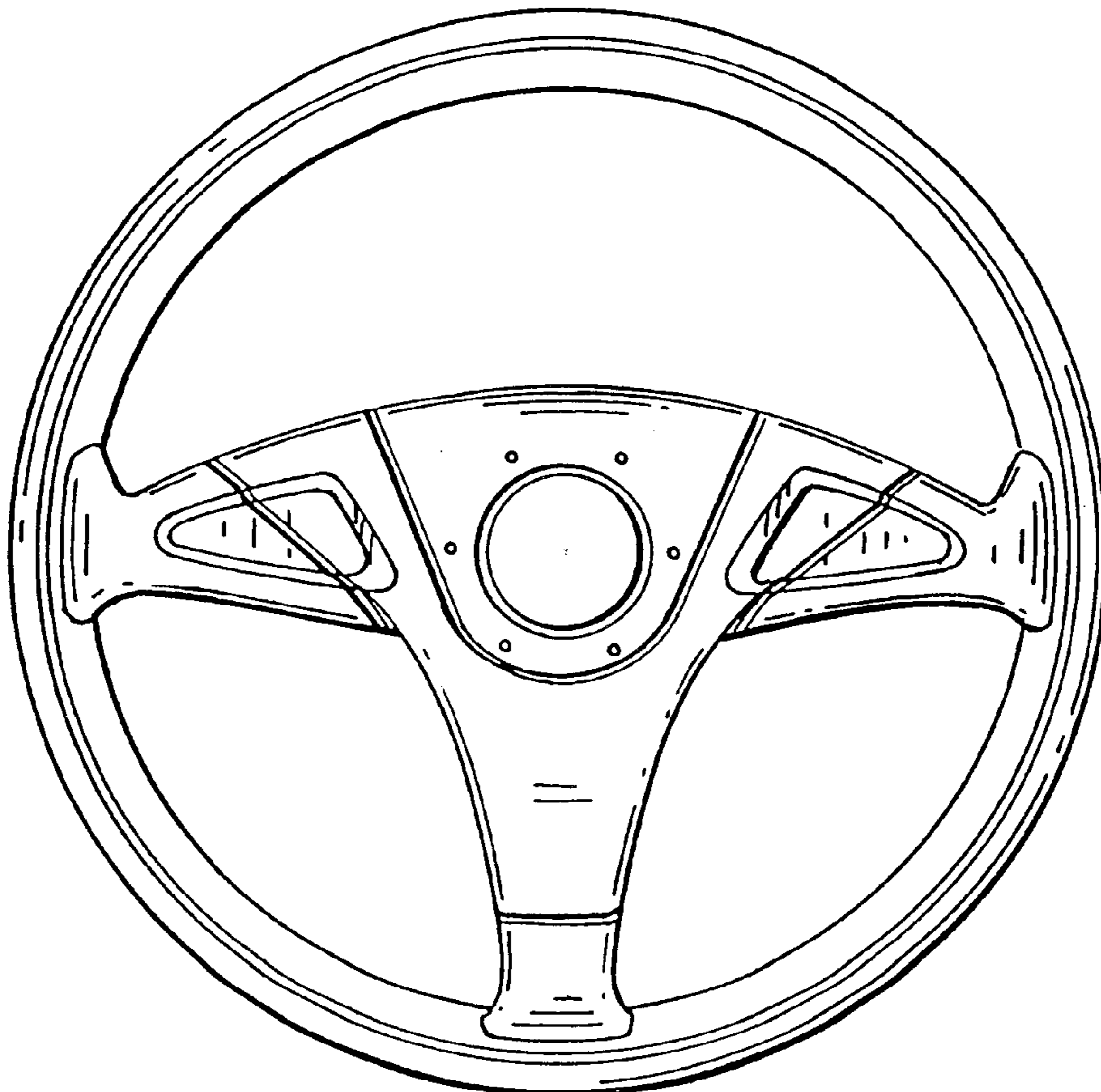

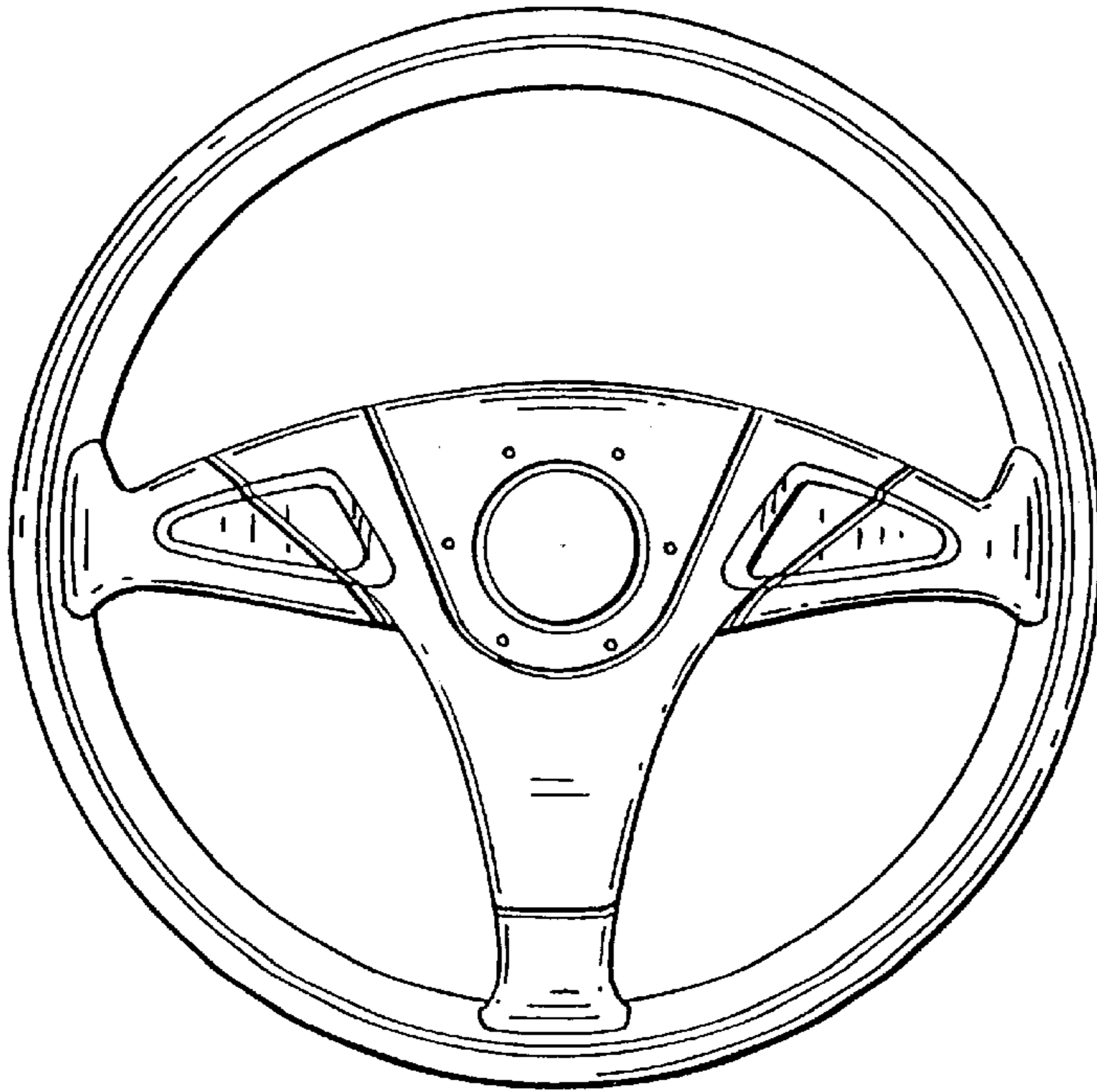

FIG. 1

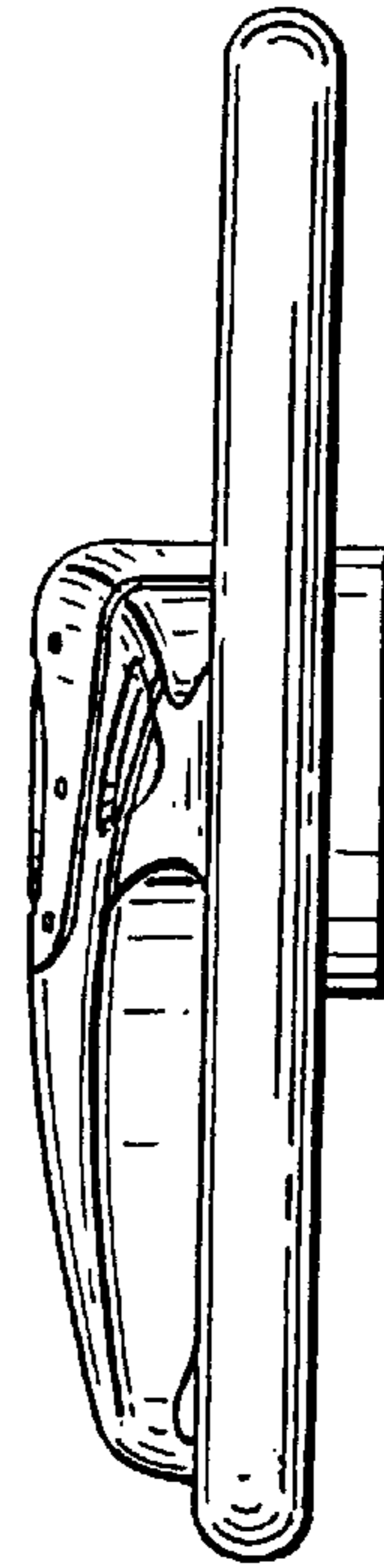

FIG. 2

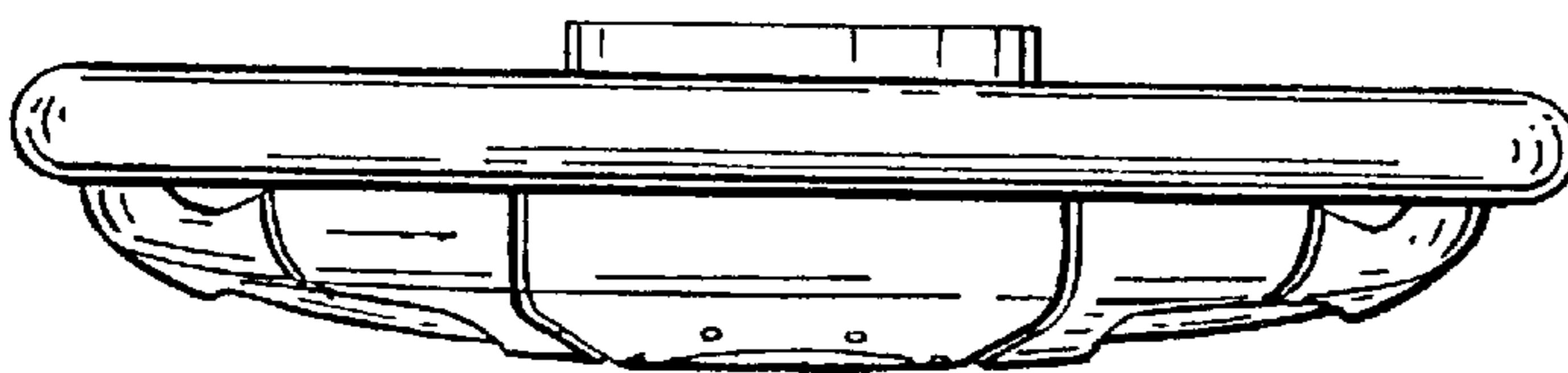

FIG. 3

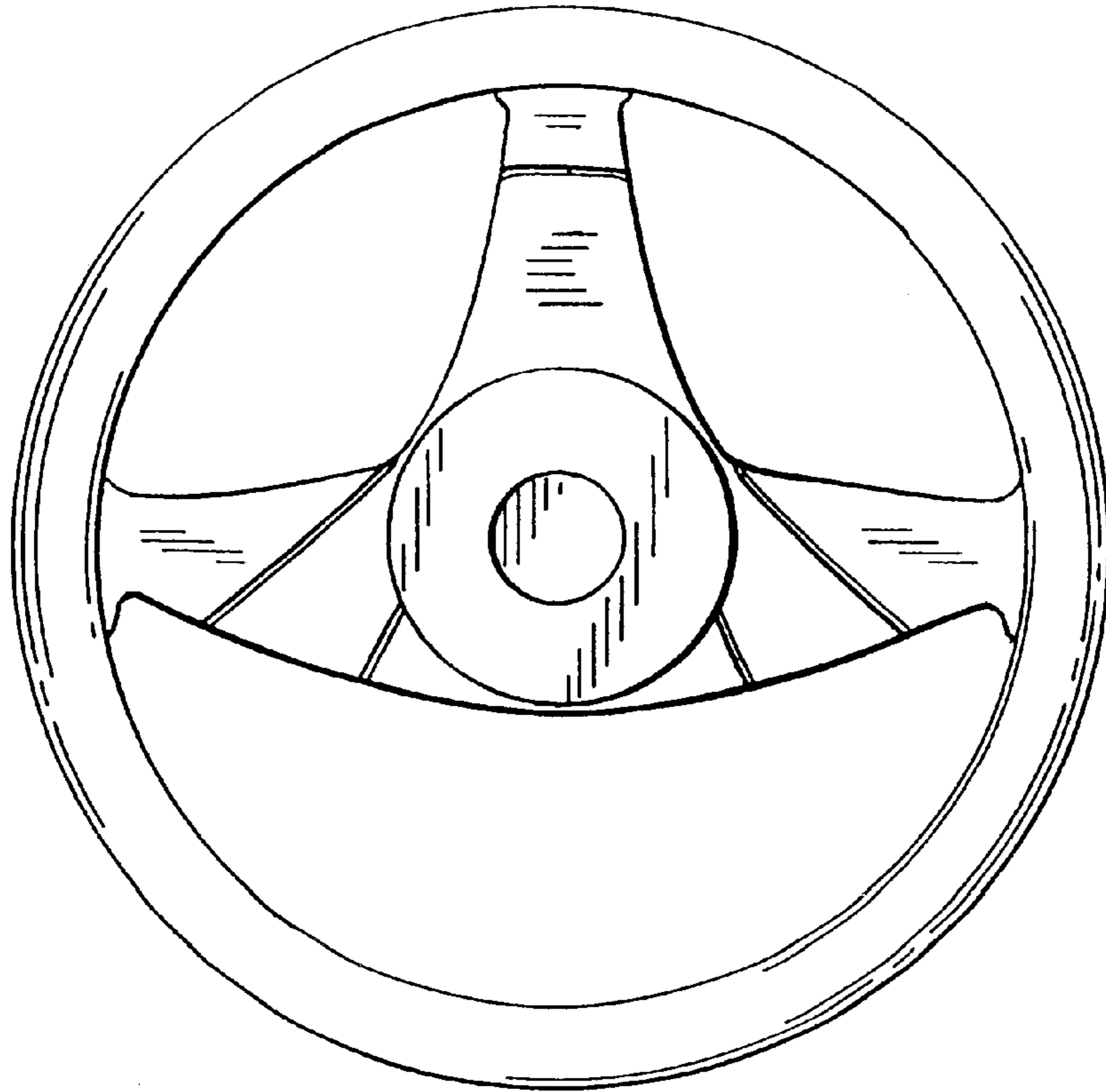

FIG. 4

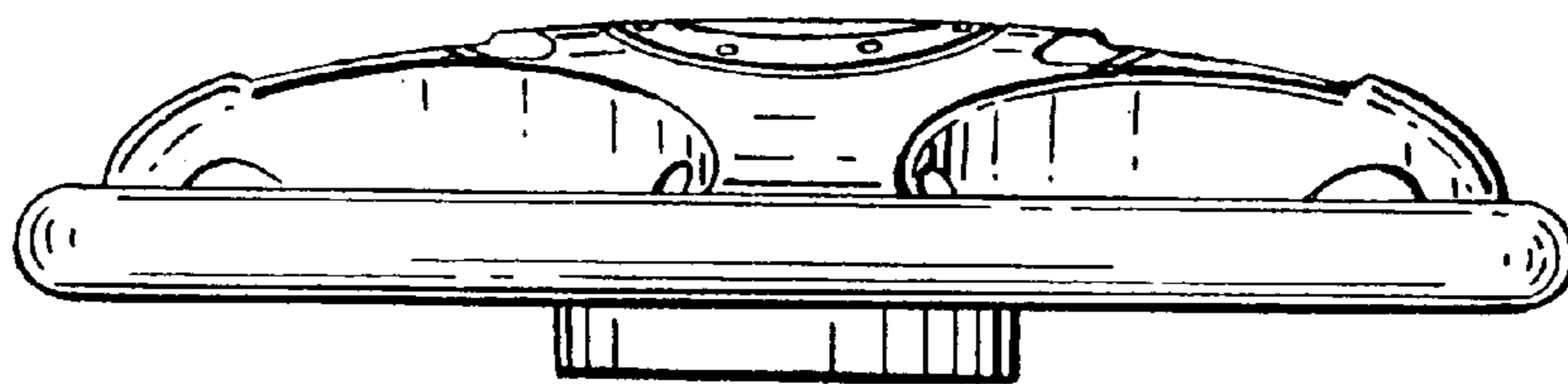

FIG. 5