



US00D420782S

**United States Patent** [19]  
**Sandt et al.**

[11] **Patent Number: Des. 420,782**

[45] **Date of Patent: \*\* Feb. 22, 2000**

[54] **STOCKCAR RACING HAT WITH EXPANDABLE HEAD SECTION**

[76] Inventors: **Terry M. Sandt**, P.O. Box 1047, Daytona Beach, Fla. 32115; **Travis W. White**, 1754 Eastern Rd., S. Daytona, Fla. 32119

[\*\*] Term: **14 Years**

[21] Appl. No.: **29/097,161**

[22] Filed: **Nov. 30, 1998**

[51] **LOC (7) Cl.** ..... **02-03**

[52] **U.S. Cl.** ..... **D2/869**

[58] **Field of Search** ..... D2/865, 866, 869, D2/870, 871, 873; 2/171, 181, 195.1, 200.3, 209.13; 446/26, 27; D21/548, 549, 560

[56] **References Cited**

**U.S. PATENT DOCUMENTS**

- D. 325,943 5/1992 Kuperman ..... D21/560
- D. 357,344 4/1995 Norton .
- D. 368,354 4/1996 Edwards, Jr. .... D2/871
- D. 372,571 8/1996 Venditto, Jr. .

- D. 393,535 4/1998 Farber .
- D. 393,536 4/1998 Buffer et al. .
- D. 402,334 12/1998 Thomas ..... D21/548
- 2,679,395 5/1954 Green ..... 446/26
- 3,596,289 8/1971 Adickes .
- 4,991,235 2/1991 Warner .
- 5,768,714 6/1998 Bowhey .

*Primary Examiner*—Paula A. Mortimer  
*Attorney, Agent, or Firm*—Edward M. Livingston, Esq.

[57] **CLAIM**

The ornamental design for a stockcar racing hat with expandable head section, as shown and described.

**DESCRIPTION**

FIG. 1 is a perspective view of a stockcar racing hat with expandable head section showing our new design; FIG. 2 is a front elevational view thereof; FIG. 3 is a rear elevational view thereof; FIG. 4 is a bottom view thereof showing the expandable head section; FIG. 5 is a top view thereof; FIG. 6 is a left side elevational view thereof; and, FIG. 7 is a right side elevational view thereof.

**1 Claim, 2 Drawing Sheets**

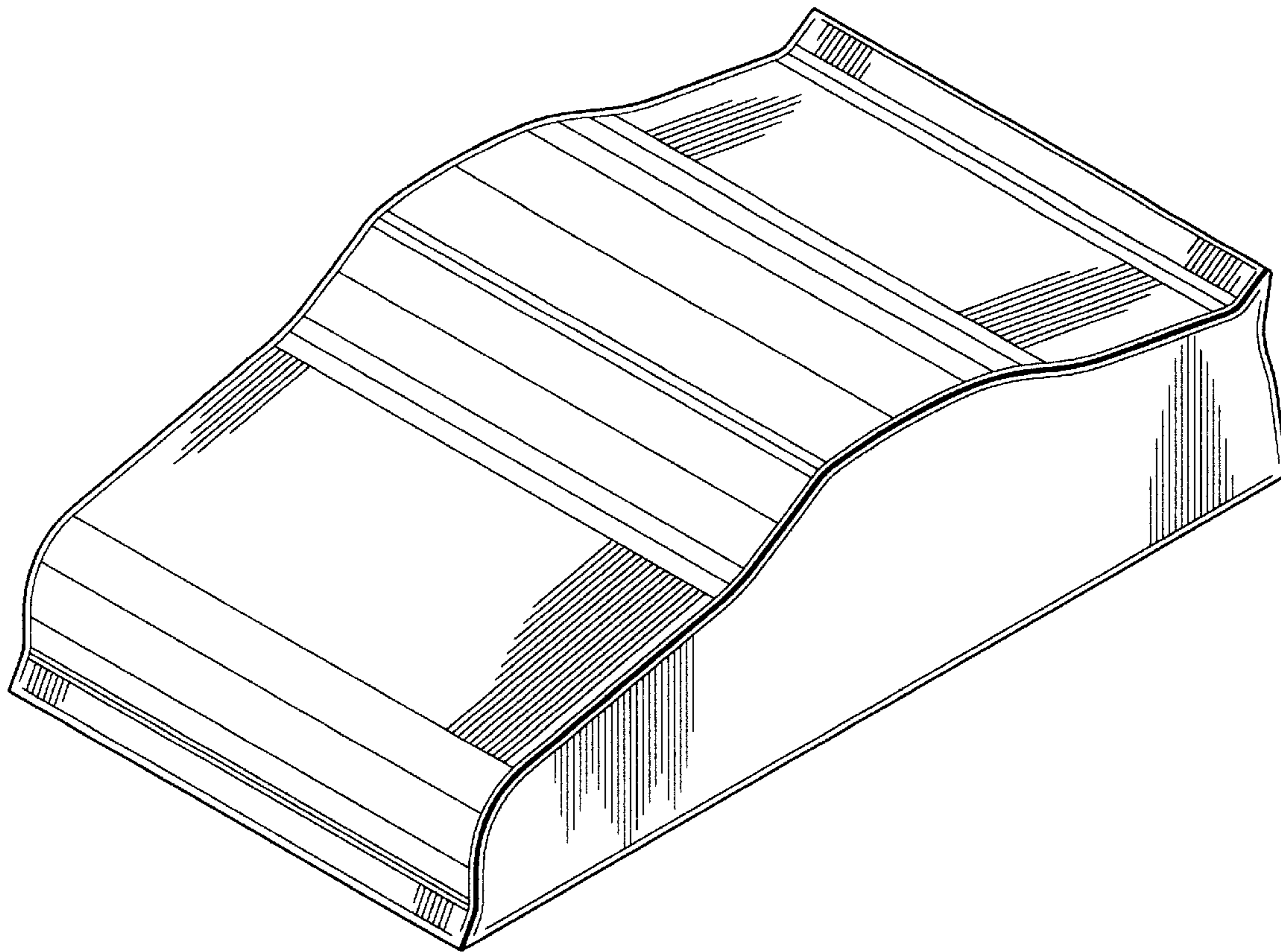

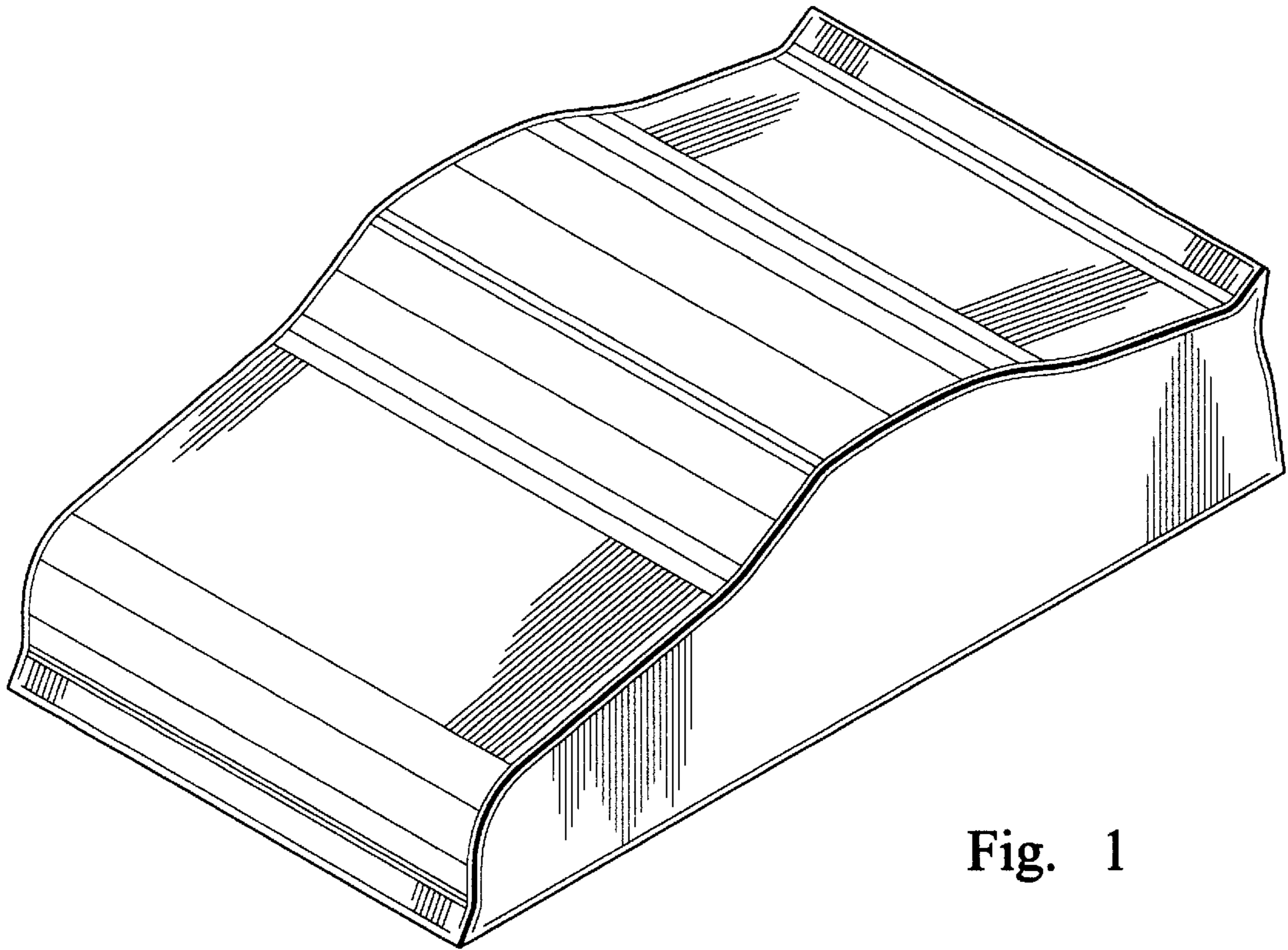

Fig. 1

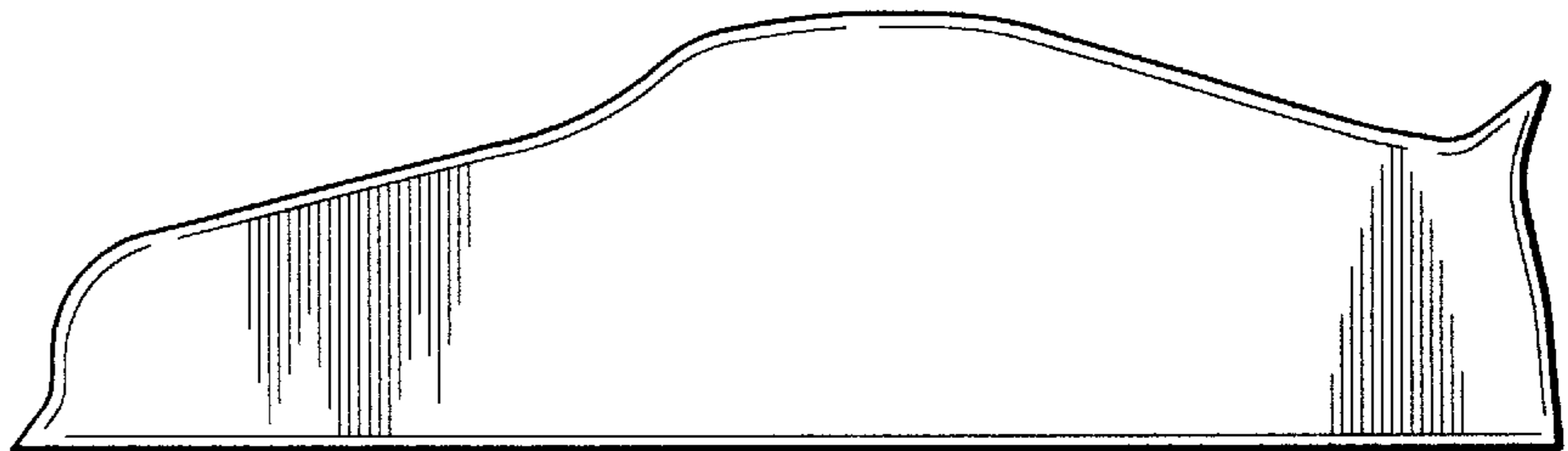

Fig. 2

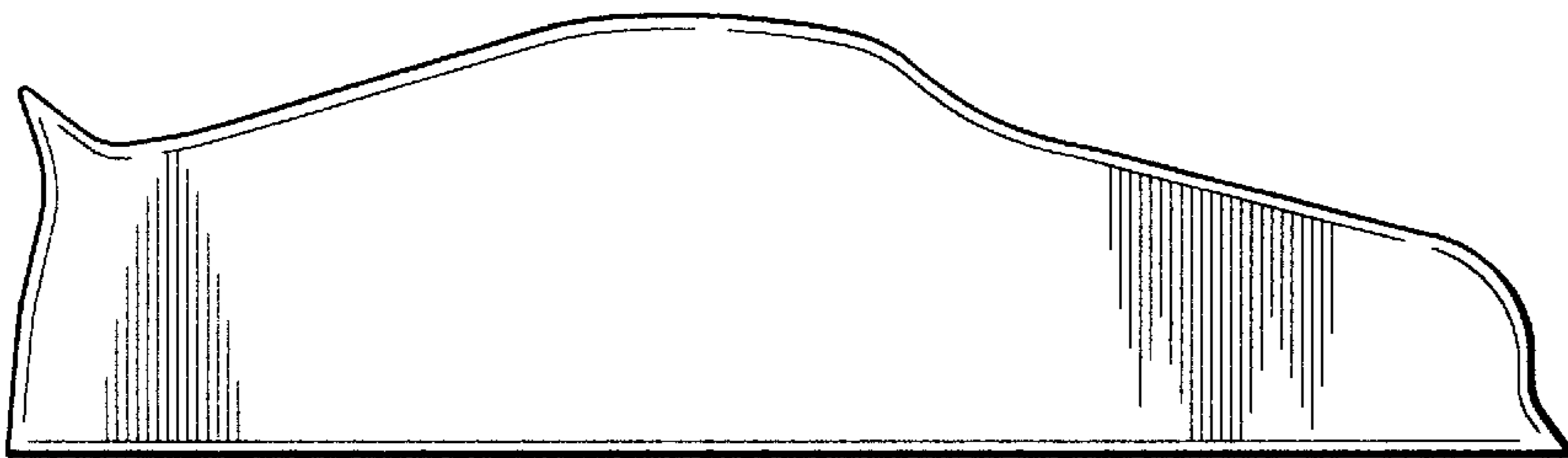

Fig. 3

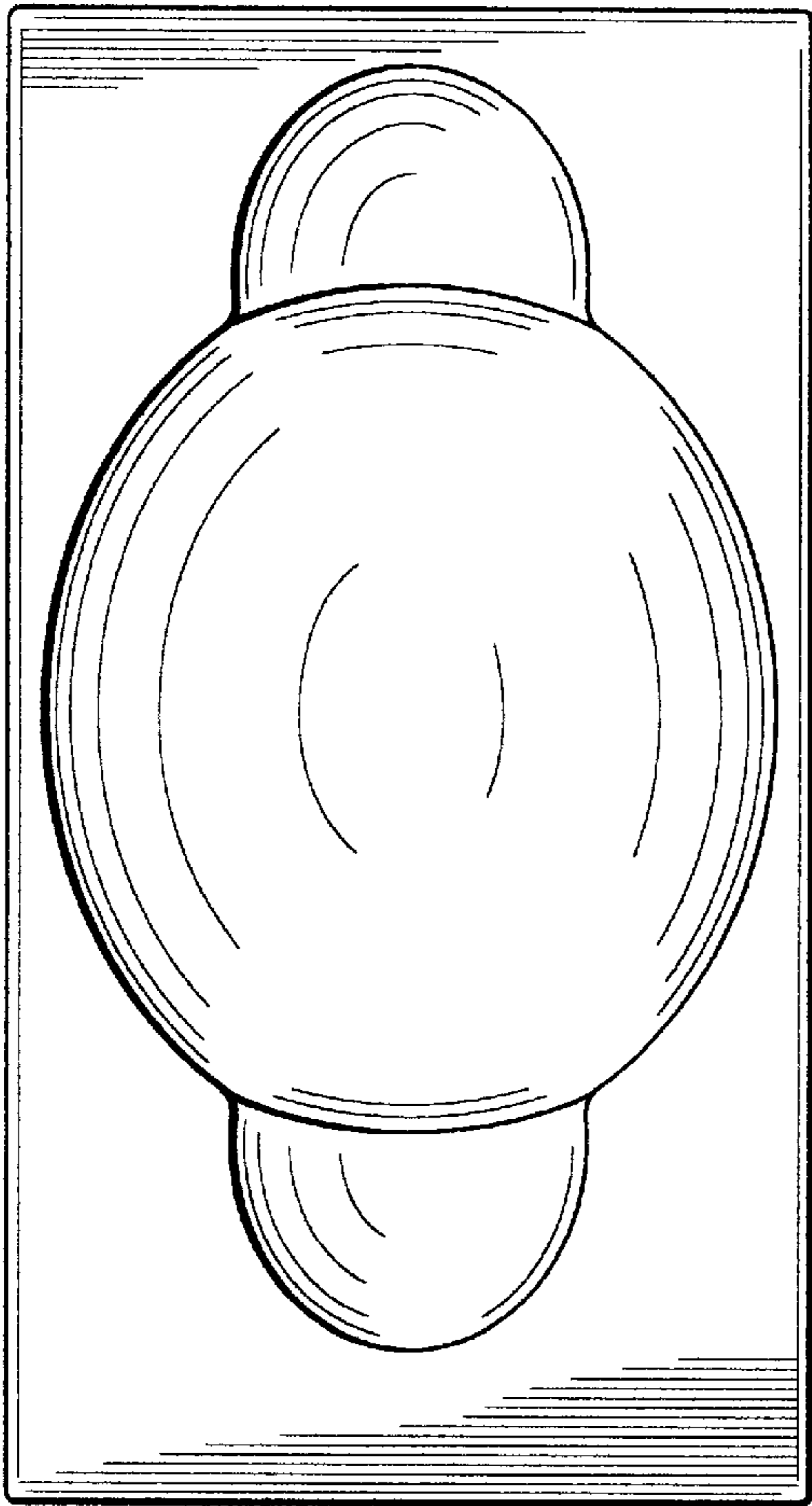

Fig. 4

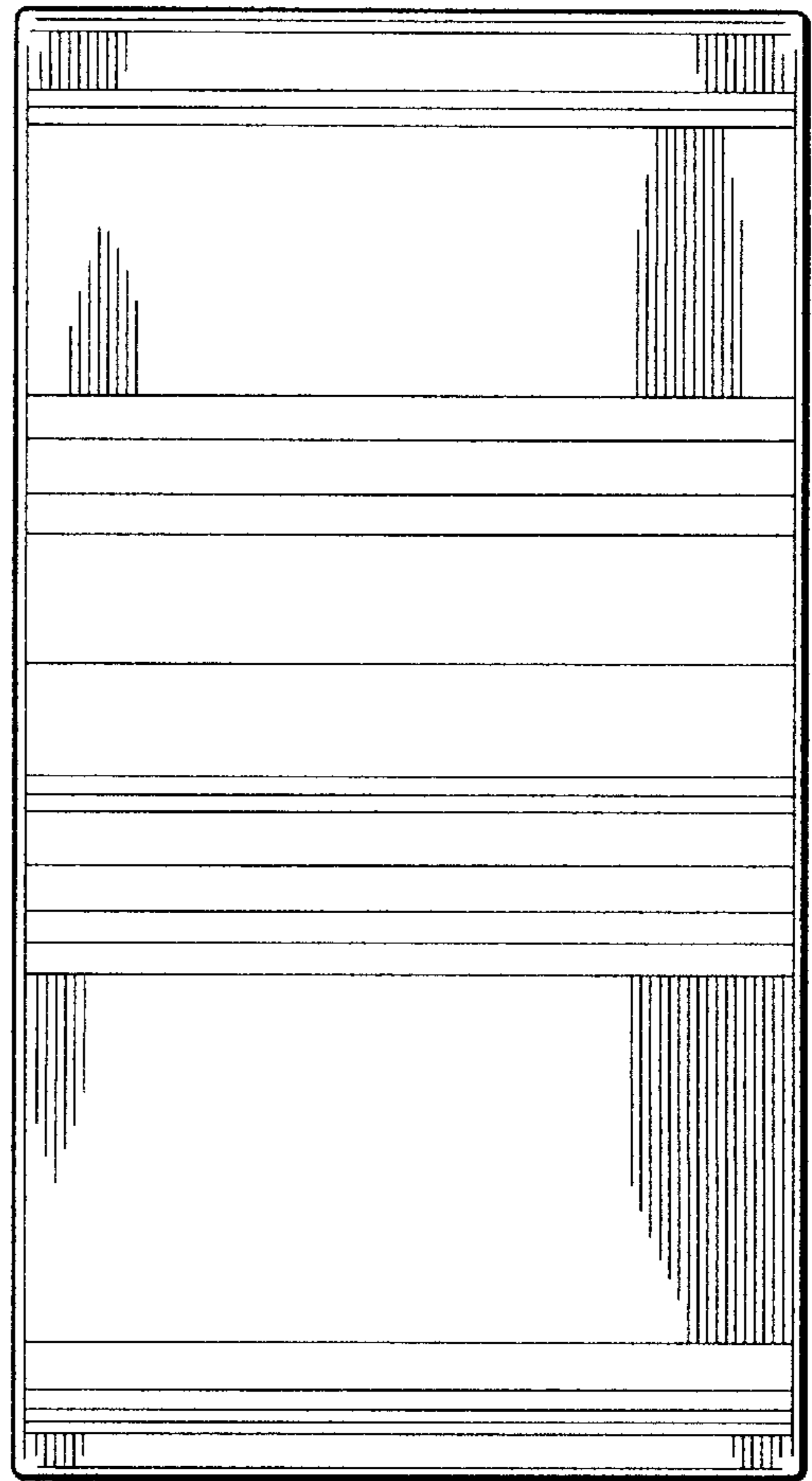

Fig. 5

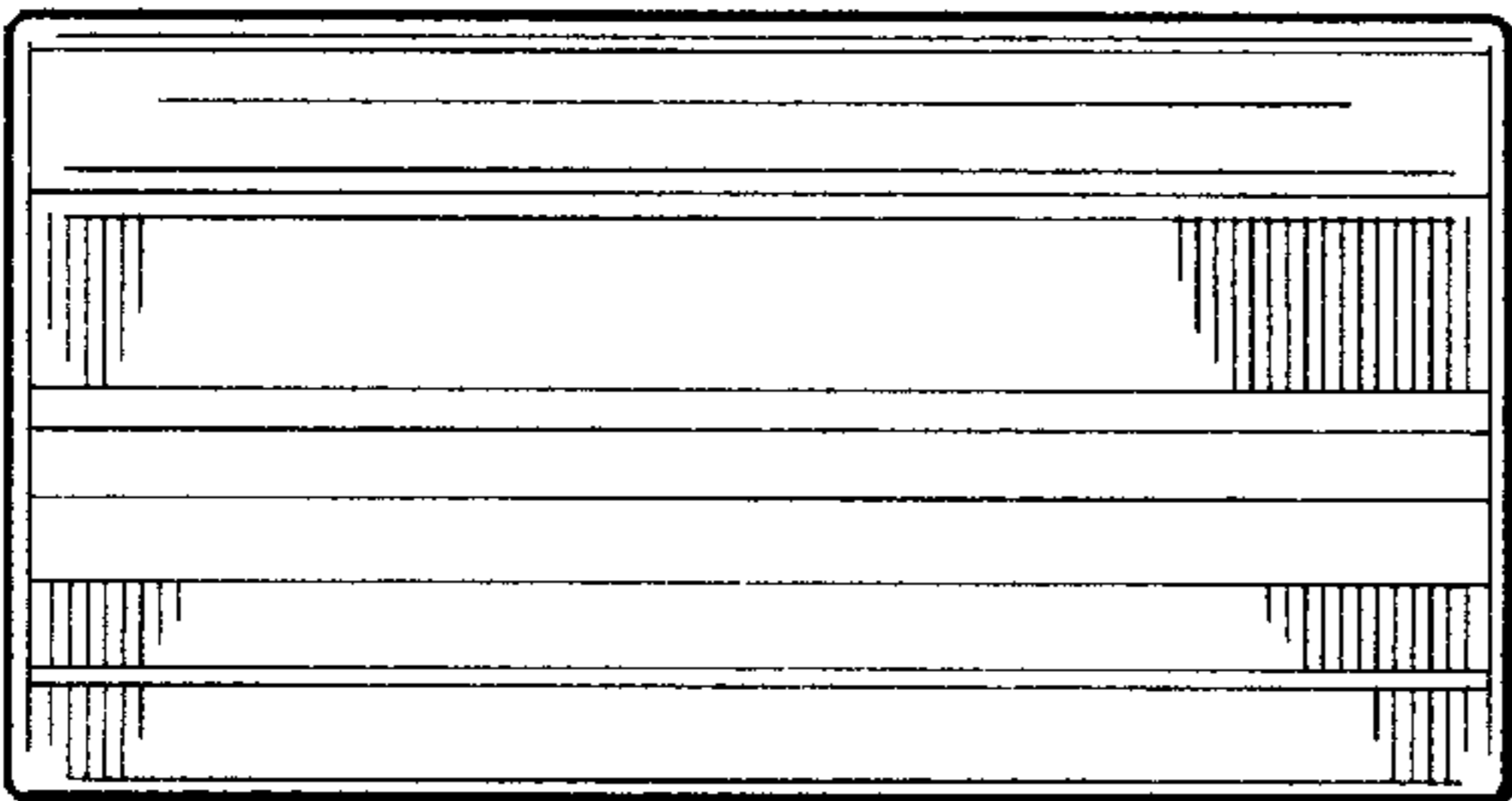

Fig. 6

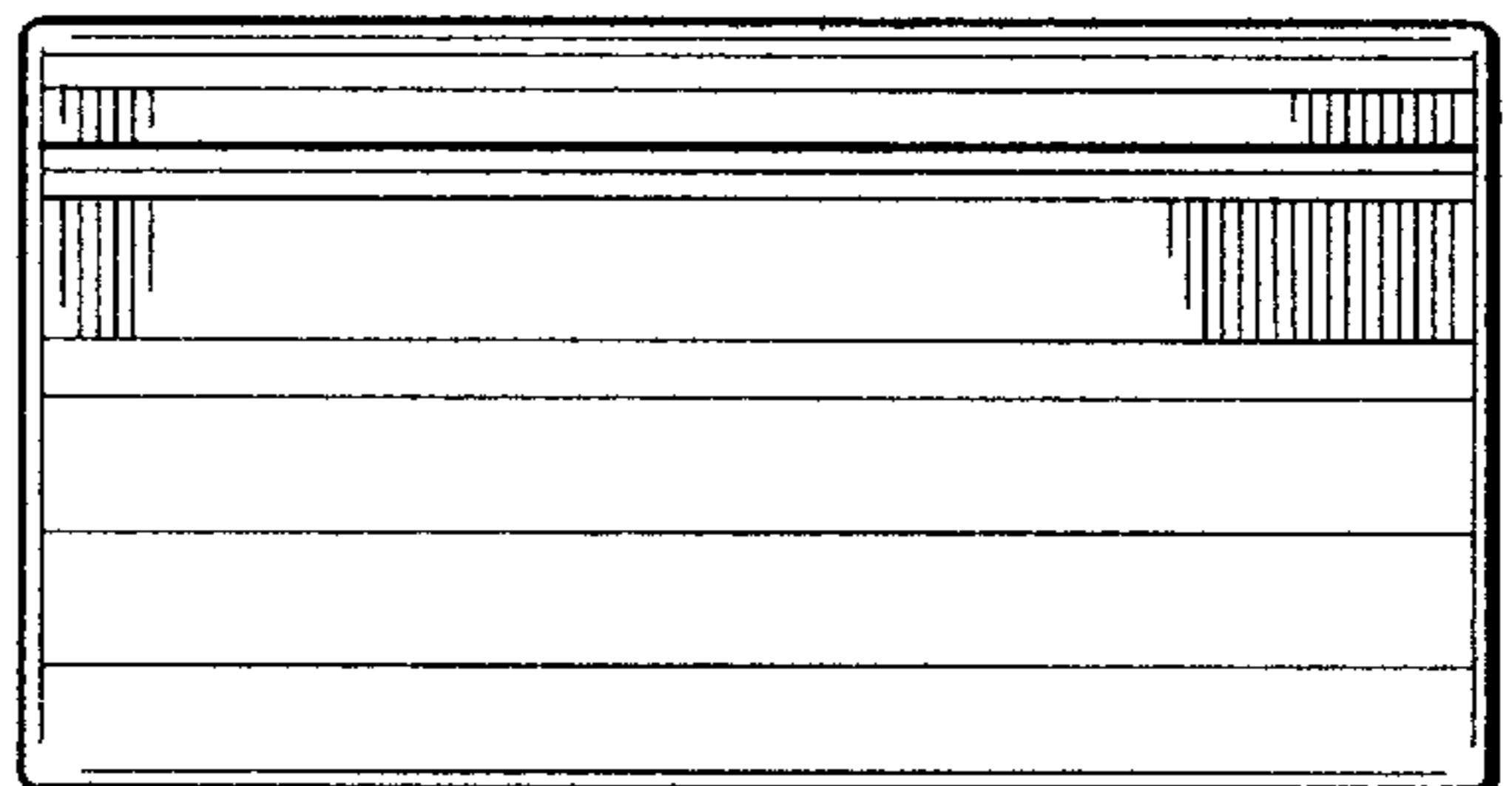

Fig. 7