



US00D420720S

# United States Patent [19]

[11] **Patent Number: Des. 420,720**

**Teran et al.**

[45] **Date of Patent: \*\* Feb. 15, 2000**

[54] **APPARATUS FOR THE PURIFICATION OF WATER**

[75] Inventors: **Alfredo J. Teran**, Cape Canaveral; **John R. Derrick, Jr.**, Rockledge; **Nidal A. Samad**, Merritt Island; **W. Todd Willoughby**; **Igor A. Vassiliev**, both of Cape Canaveral; **Louis V. Mangicarpa**; **Carlos V. Diaz**, both of Merritt Island, all of Fla.

[73] Assignee: **AJT & Associates**, Cape Canaveral, Fla.

[\*\*] Term: **14 Years**

[21] Appl. No.: **29/091,298**

[22] Filed: **Jul. 27, 1998**

### Related U.S. Application Data

[63] Continuation-in-part of application No. 08/893,465, Jul. 11, 1997, which is a continuation-in-part of application No. 08/494,232, Jun. 23, 1995, abandoned.

[51] **LOC (7) Cl.** ..... **23-01**

[52] **U.S. Cl.** ..... **D23/200**

[58] **Field of Search** ..... D23/200, 207, D23/209; 210/741, 241

### [56] References Cited

#### U.S. PATENT DOCUMENTS

D. 359,055	6/1995	Drago et al.	.....	D23/207
D. 370,050	5/1996	Dea et al.	.....	D23/207
1,821,266	9/1931	Lewis	.....	210/192

(List continued on next page.)

#### OTHER PUBLICATIONS

PCI-WEDECO Environmental Technologies, "A leader in Ozone technology", Oct. 1997.  
 PCI Ozone & Control Systems, Inc., "Introducing Series 400 Ozone Monitors".  
 PCI Ozone & Control Systems, Inc., "Big Performance in Small Packages".

WEDECO Environmental Technologies Water-Soil-Air, "The corporate image of WEDECO".  
 Ozonia North America, "The OZAT Compact Ozone Generation Units" 1994.  
 Ozonia North America, "Ozone in the Advancement of Drinking Water Treatment Technology".  
 Miox Corporation, "Premium Disinfection System Enters Wastewater and Odor Control Markets", Aug. 5, 1997.  
 Miox Corporation, "Evaluation of the Miox System For Killing Coliform Bacteria and T2 Virus", Mar. 10, 1997.  
 Miox Corporation, "Miox Safety Advantages", May 30, 1997.  
 Miox Corporation, "Simply a Safer Way to Disinfect Water".  
 Miox Corporation, "Simple, Safe, Effective Water Disinfection Services and Equipment", Aug. 7, 1997.  
 GDT Corporation, "The GDT Process In Municipal Water Treatment Applications".  
 Air-O<sub>3</sub>-Tech, Oxygen and Ozone Generators, "Preserving Resources, Both Natures and Yours!".  
 Aqua-Flo, Inc., "Ozone for a Naturally Clean Environment The Smart, Proven Alternative to Chemicals", Form #ts-313/Revised Nov. 1996.  
 Ultrapure Water, "Microbial Control Ozone, The Process Water Sterilant", Nov. 1988.

(List continued on next page.)

*Primary Examiner*—Robin V. Taylor  
*Attorney, Agent, or Firm*—Stein, Schifino & Van der Wall

### [57] CLAIM

The ornamental design of an apparatus for the purification of water, as shown and described.

### DESCRIPTION

FIG. 1 is a left front perspective view of an apparatus for the purification of water showing our new design;  
 FIG. 2 is a right front perspective view thereof;  
 FIG. 3 is a front elevation view thereof;  
 FIG. 4 is a rear elevation view thereof;  
 FIG. 5 is a right-side view thereof;  
 FIG. 6 is a left-side view thereof; and,  
 FIG. 7 is a top perspective view thereof.

**1 Claim, 7 Drawing Sheets**

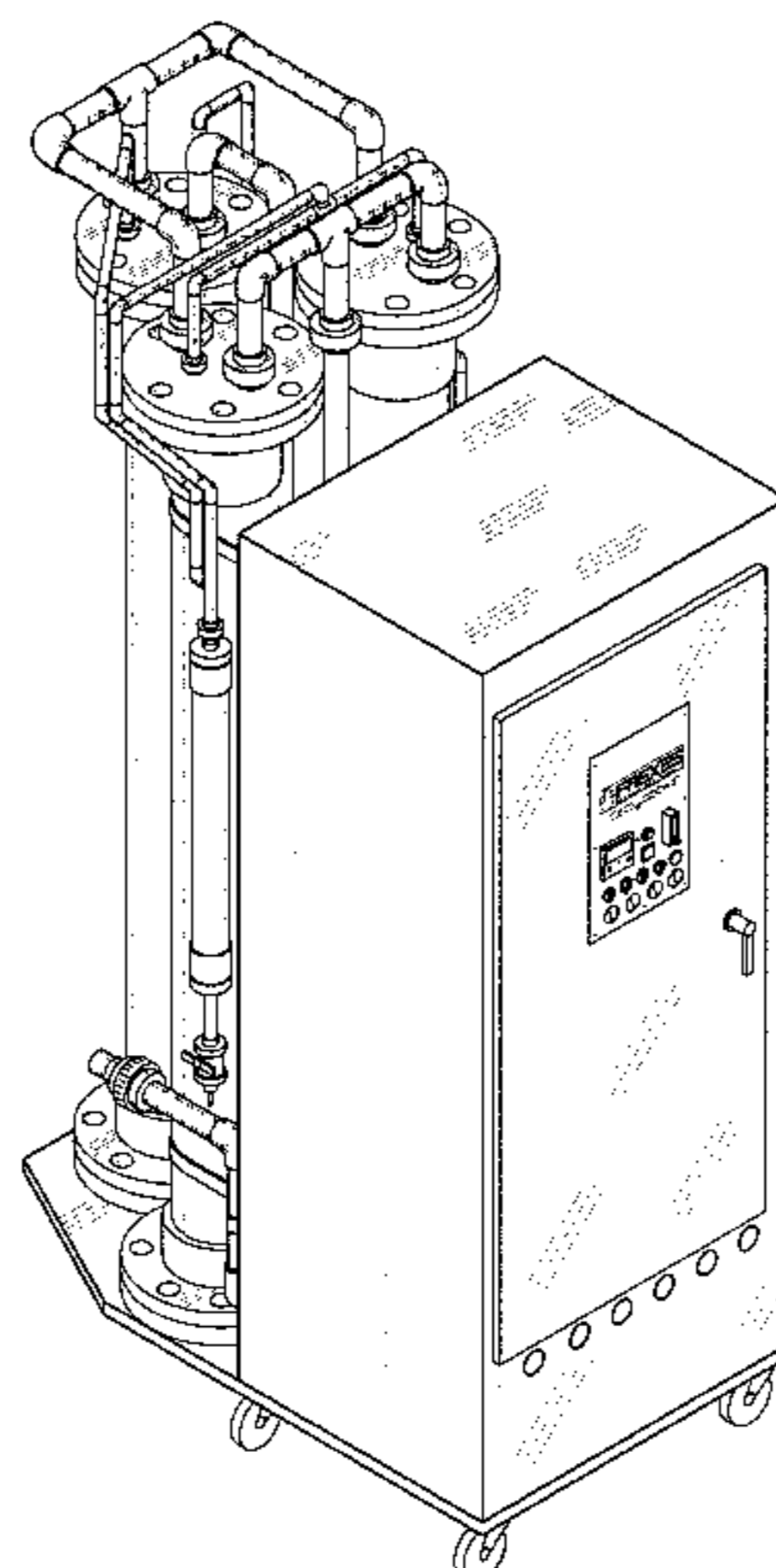

## U.S. PATENT DOCUMENTS

2,043,701	6/1936	Hartman	210/760
2,812,861	11/1957	Bickford	210/192
3,445,001	5/1969	La Raus	210/192
3,448,045	6/1969	Hess et al.	210/192
3,660,277	5/1972	McWhirter et al.	210/760
3,669,776	6/1972	La Raus	210/192
3,680,704	8/1972	Schaefer	210/170
3,823,728	7/1974	Burris	210/760
3,856,671	12/1974	Lee et al.	210/192
3,945,918	3/1976	Kirk	210/255
4,007,118	2/1977	Ciambrone	210/63
4,043,913	8/1977	Hintermeister	210/169
4,049,552	9/1977	Arff	210/192
4,053,403	10/1977	Bachhofer et al.	210/760
4,098,691	7/1978	Filby	210/29
4,104,166	8/1978	La Raus	210/195
4,132,637	1/1979	Key et al.	210/760
4,136,027	1/1979	Sakamoto et al.	210/632
4,156,652	5/1979	Wiest	210/205
4,250,040	2/1981	La Raus	210/760
4,252,654	2/1981	Leitzke et al.	210/760
4,255,257	3/1981	Greiner et al.	210/709
4,256,574	3/1981	Bhargava	210/614
4,572,821	2/1986	Brodard et al.	210/760
4,597,877	7/1986	Gaia	210/750
4,663,089	5/1987	Lowry et al.	210/221.2
4,696,739	9/1987	Pedneault	210/121
4,780,287	10/1988	Zeff et al.	244/186.3
4,798,669	1/1989	Bachhofer et al.	210/109
4,834,872	5/1989	Overath	210/151
4,836,921	6/1989	Hahn et al.	210/241
4,883,589	11/1989	Konon	210/140
4,898,679	2/1990	Siegel et al.	210/752
5,053,140	10/1991	Hurst	210/704
5,055,205	10/1991	White	211/241
5,082,558	1/1992	Burris	210/167
5,104,576	4/1992	Ditzler et al.	210/195.1
5,114,576	5/1992	Ditzler et al.	210/195.1
5,116,574	5/1992	Pearson	422/3
5,173,257	12/1992	Pearson	422/3
5,178,755	1/1993	La Crosse	210/195.1
5,192,452	3/1993	Mitsui et al.	210/760
5,207,993	5/1993	Burris	422/256
5,273,664	12/1993	Schulz	210/759
5,302,298	4/1994	Leitzke	210/748
5,302,356	4/1994	Shadman et al.	422/186.3
5,326,469	7/1994	Thompson	210/192
5,336,413	8/1994	Van Staveren	210/650
5,346,617	9/1994	Costello	210/192
5,376,265	12/1994	Szabo	210/188
5,376,266	12/1994	Broussard	210/195
5,397,480	3/1995	Dickerson	210/752
5,458,789	10/1995	Dickerson et al.	210/750
5,466,374	11/1995	Bachhofer et al.	210/610
5,498,347	3/1996	Richard	210/739
5,545,330	8/1996	Ehrlich	210/703

## OTHER PUBLICATIONS

Aqua-Flo, Inc., "Installation instructions for Model HD-10".

Aqua-Flo, Inc., "Air Filter/Drier Model AFD-100MS".

Aqua-Flo, Inc., "Ozone Air Prep Equipment Guide", Form #ts-315/Revised Aug. 1997.

Envirovision Modular Systems, "EMS Cooling Tower Treatment System Model 410", Feb. 1997.

HydroMax, Inc., "High Performance Water Purification Systems—Reverse Osmosis SL Series".

Clearwater Tech, Inc., OAS-20 "Air Source and Timed Ozonation Control Center".

Ozone Pure Water, Inc., "Increase Ozone Production & Extend Ozone Equipment Life With Ozone Pure Water Air Dryers".

Progressive Equipment Corp., "Electronic system treats cooling tower water", 1987.

Progressive Equipment Corp., "Multi-Basket Strainers and Multi-Bag Filters".

Prozone, "Pools and Spas Made Drinking Water Pure", 1995.

Vistek Corporation, "Customer Evaluation for Specifying Ozonator Applications".

Rainbowair Activators, Inc., "Presents a Line of Portable-Powerful Professional electronic Ozone Generators".

Sun River Innovations, Ltd., "Trilogy Ozone Systems".

Sun River Innovations, Ltd., "The SR 1959 System Process", 1995.

"The Redundant Water Purifier", Food Protection Report, vol. 11, No. 2, Feb. 1995.

Isom, John, "Georgia Member Receives Visit from Agriculture Department; Product Test Reports Provide Answers to Potential Problem", Ice News.

"Icemasters Reacts to Concern About Safety of Public Water Supplies; Installs State-of-the-Art Water Treatment System", Ice News.

Sun River Innovations, Ltd., "SR1959 Packaged Ice Systems Sizing Guidelines", 1995.

Recer, Paul, "Chlorination study finds cancer link", Lexington Herald-Leader, Jun. 18, 1997.

Sun River Innovations, Ltd., Finally a Solution for Cost-Effective Environmentally Sound Cooling Tower Water Treatment, 1996.

Sun River—CTO Systems, Ozone Cooling Water Treatment—A Technical Overview and Application History.

U.S. Department of Energy, "Ozone Treatment for Cooling Towers".

Echols, Joseph T. and Mayne, Sherman T., "Cooling tower management using ozone instead of multichemicals", Ashrae Journal, Jun. 1990.

EPRI Industrial Program—environment & Energy Management, "Ozonation of cooling tower water", No. 3, 1992.

Water Purification International, "Pre-Treat Coagulation (PTC) An Innovative Technology Providing Solutions for the 21<sup>st</sup> Century", 1997.

Water Purification International, "WPI—water Purification International History", 1997.

In USA, Incorporated, "Continuous Process Ozone Instrumentation—a complete line of ozone monitoring & control systems".

Ozonair International Corp., "Ozonair Water Recycling System".

Clearwater Tech, Inc., "Ultraviolet Ozone Generators; Air Cooled CD Ozone Generators; Schematics; Submittals; Technical Information & Articles".

Clearwater Tech, Inc., "Water Sterilizers by clearwater Tech.", 1995.

Clearwater Tech, Inc., "Ozone by Clearwater Tech. Quality In a Class by itself", (MZ-250 & S-1200 ultraviolet ozone generators) 1997.

Clearwater Tech, Inc., "Ozone by Clearwater Tech. Quality In a Class by itself", (CS-1400 & UV 2800 ultraviolet ozone generators) 1997.

Clearwater Tech, Inc., "Ozone by Clearwater Tech. Quality In a Class by itself", (UV-275 & PR-1300 ultraviolet ozone generators) 1997.

Clearwater Tech, Inc., "Ozone by Clearwater Tech. Quality In a Class by itself", (AD-40 Vacuum air dryer), 1995.

Clearwater Tech, Inc., "Ozone by Clearwater Tech. Quality In a Class by itself", (Electrical Interlock box), 1995.

Clearwater Tech, Inc., "Ozone by Clearwater Tech. Quality In a Class by itself", (M-1500 & P-2000 Corona Discharge ozone generators) 1993.

Clearwater Tech, Inc., "Ozone by Clearwater Tech. Quality In a Class by itself", (M-15/02 & P-20/02 Corna discharge ozone generation system), 1997.

Clearwater Tech, Inc., "Ozone by Clearwater Tech. Quality In a Class by itself", (CD-3000 Corona discharge ozone generator), 1997.

Clearwater Tech, Inc., "Ozone by Clearwater Tech. Quality In a Class by itself", (OCS-076 & OCS-140 Ozone Generation/Contacting Systems), 1995.

Clearwater Tech, Inc., "Ozone by Clearwater Tech. Quality In a Class by itself", (CD-600, CD-8000 & CD-12000 Comercial Corona discharge ozone generators).

Clearwater Tech, Inc., "POE-10 & POE-15 Complete Point-of-Entry Drinking Water Systems", 1997.

Clearwater Tech, Inc., "The Clearwater Tech CD10/AD Ozone Generation System".

Clearwater Tech, Inc., "OAS-20 Sales Guide".

Ozone Water Treatment System, "Commercial Ozone Submittal".

Precision Ozone Engineering, "Integrated Ozone Systems Engineered Specifically for the Point of Entry application".

Clearwater Tech, Inc., "Ozone Applications Seminar".

Clearwater Tech, Inc., "A Basic comparison of ozone technologies", Water Technology Magazine, Oct. 1994.

Clearwater Tech, Inc., "The benefits of ozone installation", Water Technology Magazine, Jan. 1996.

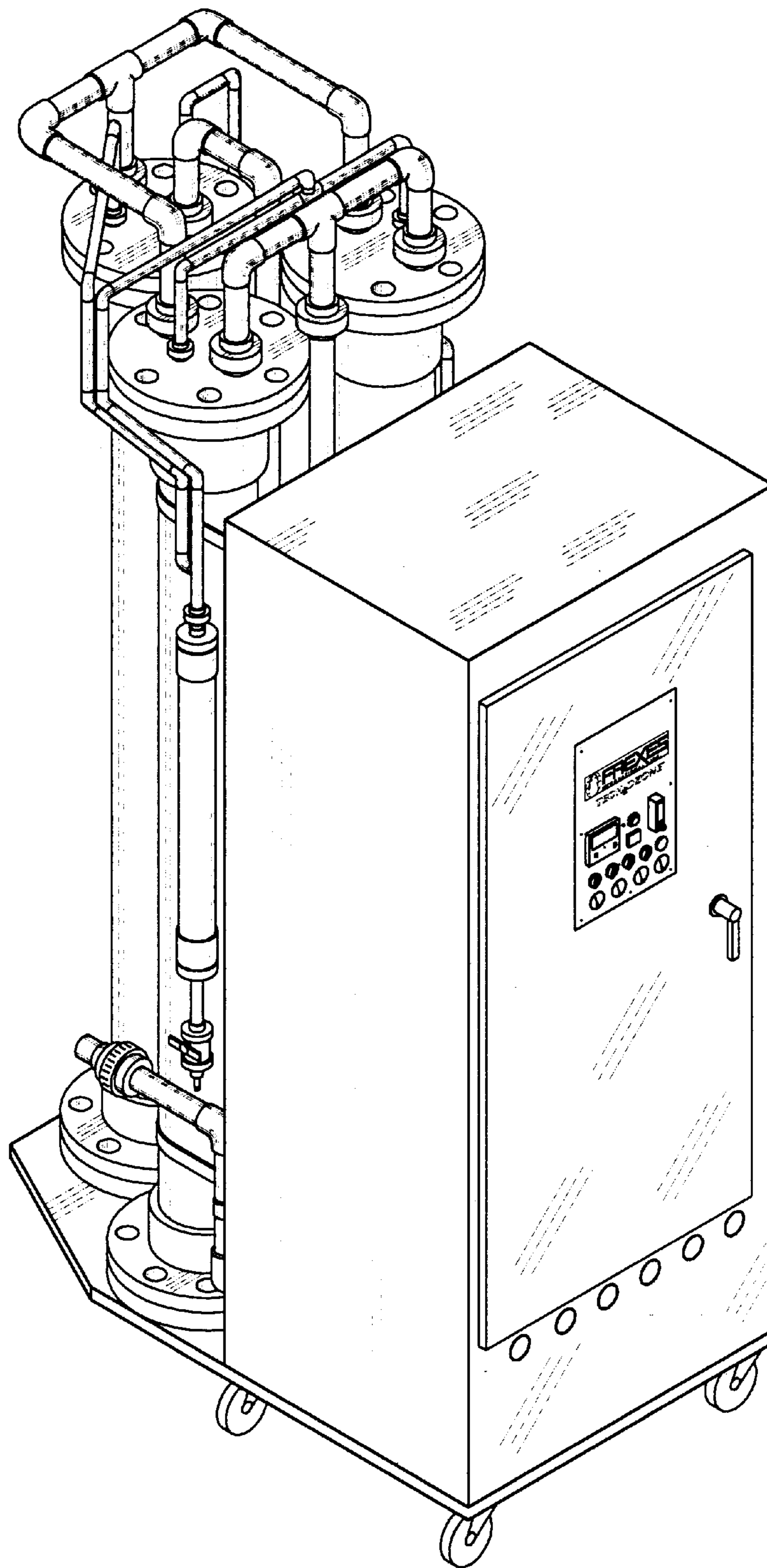

FIG. 1

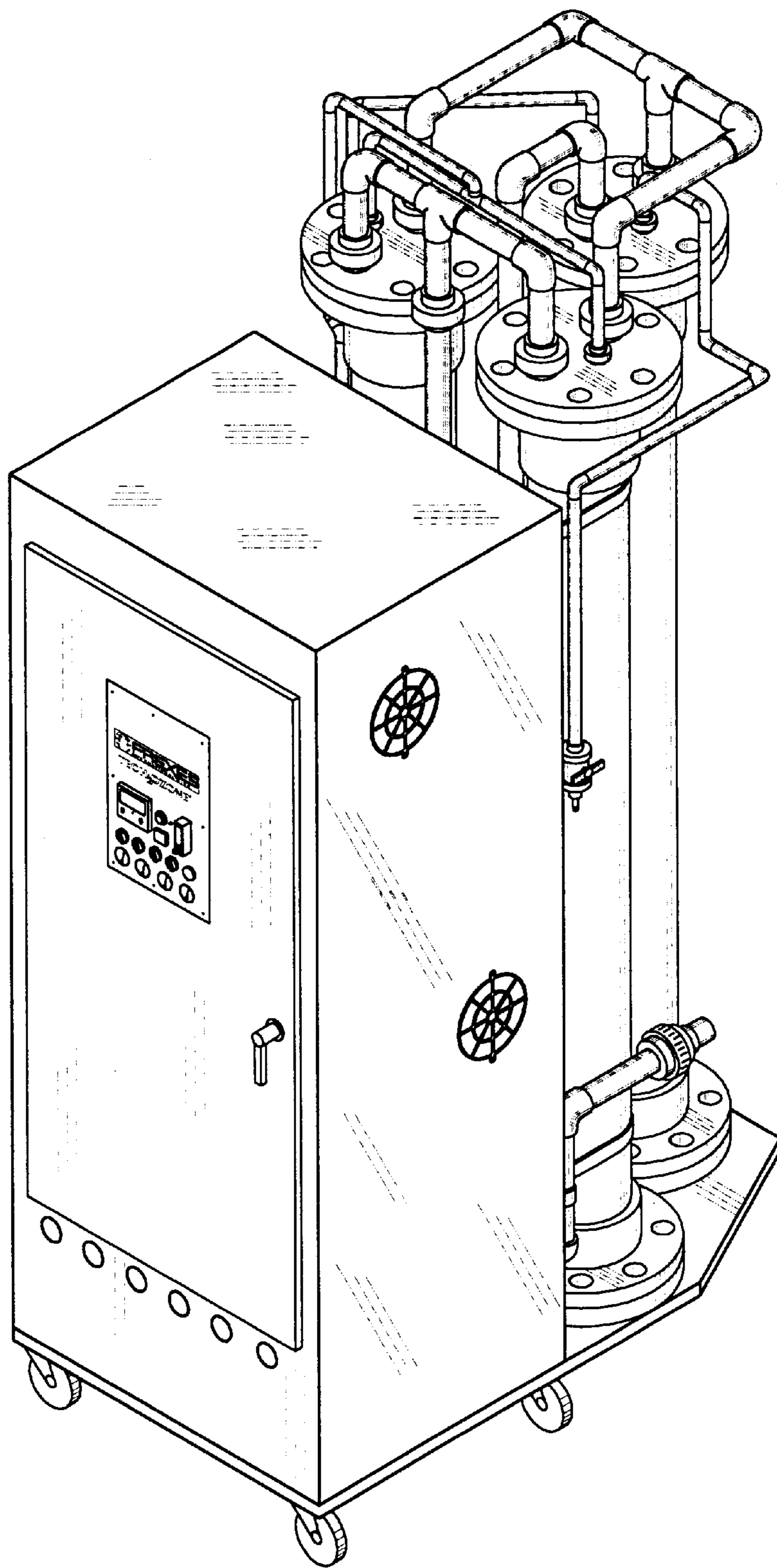

FIG. 2

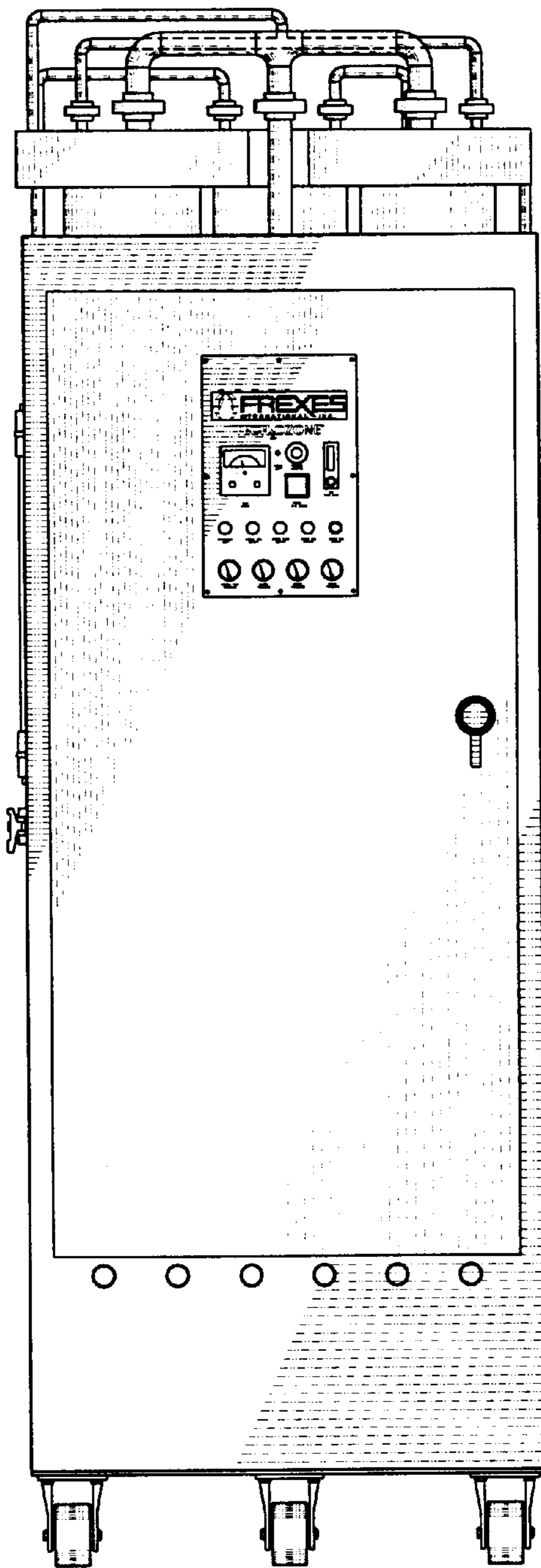

FIG. 3

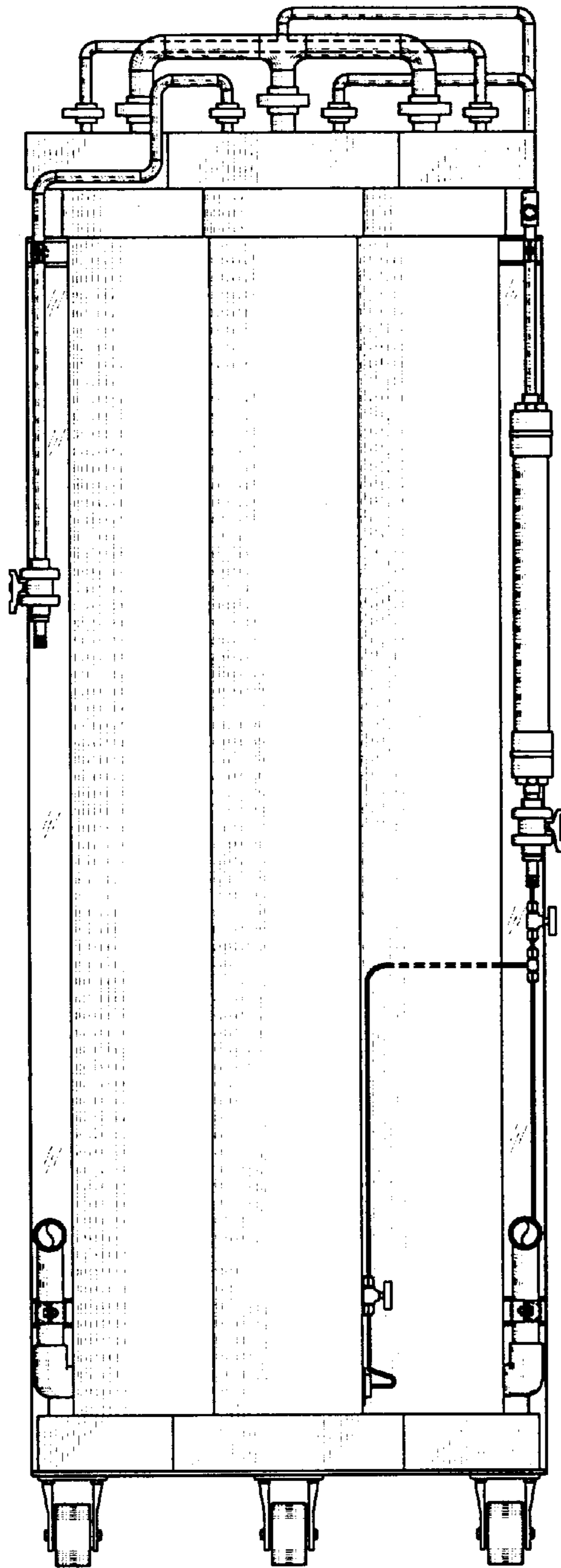

FIG. 4

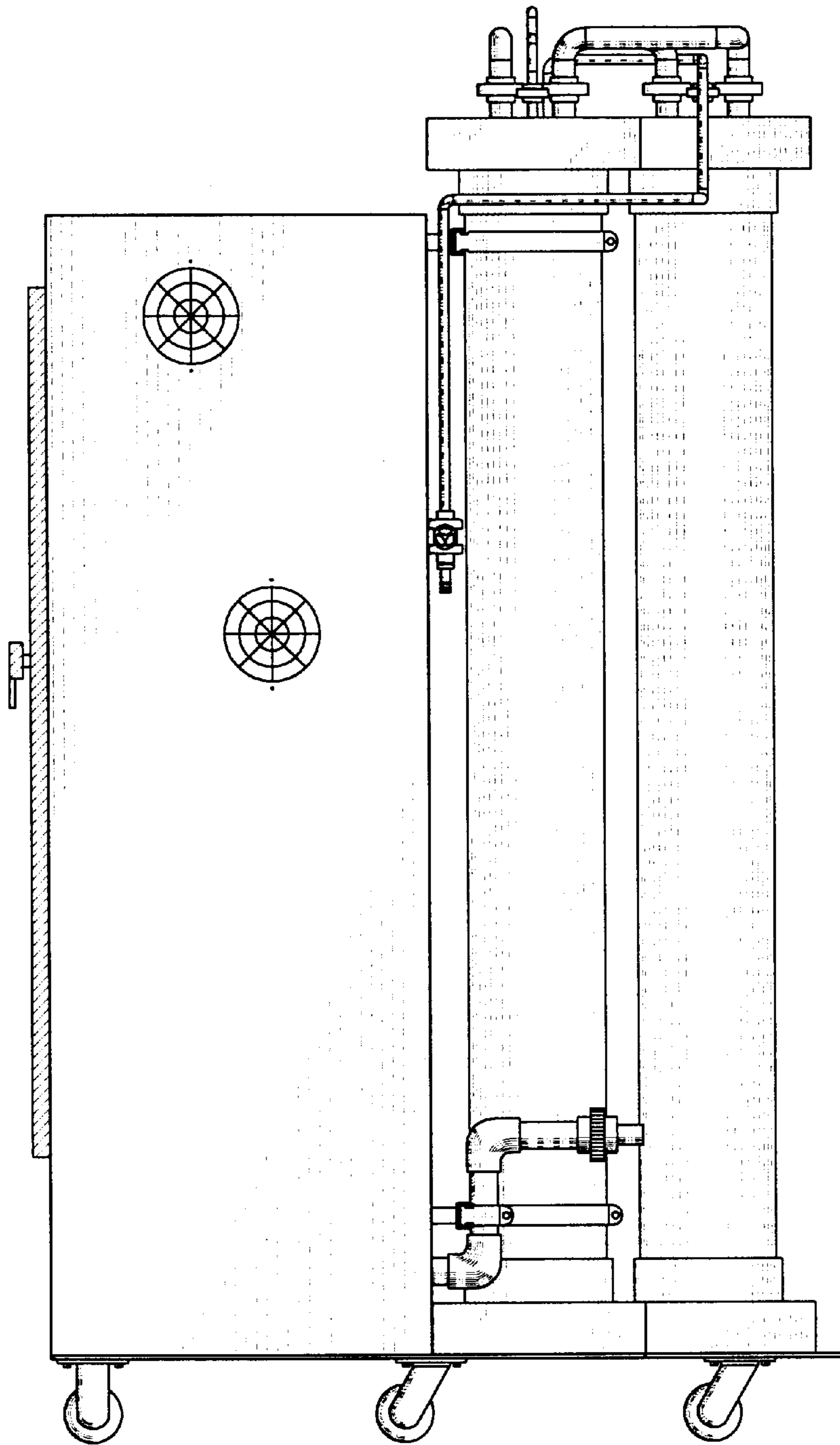

FIG. 5



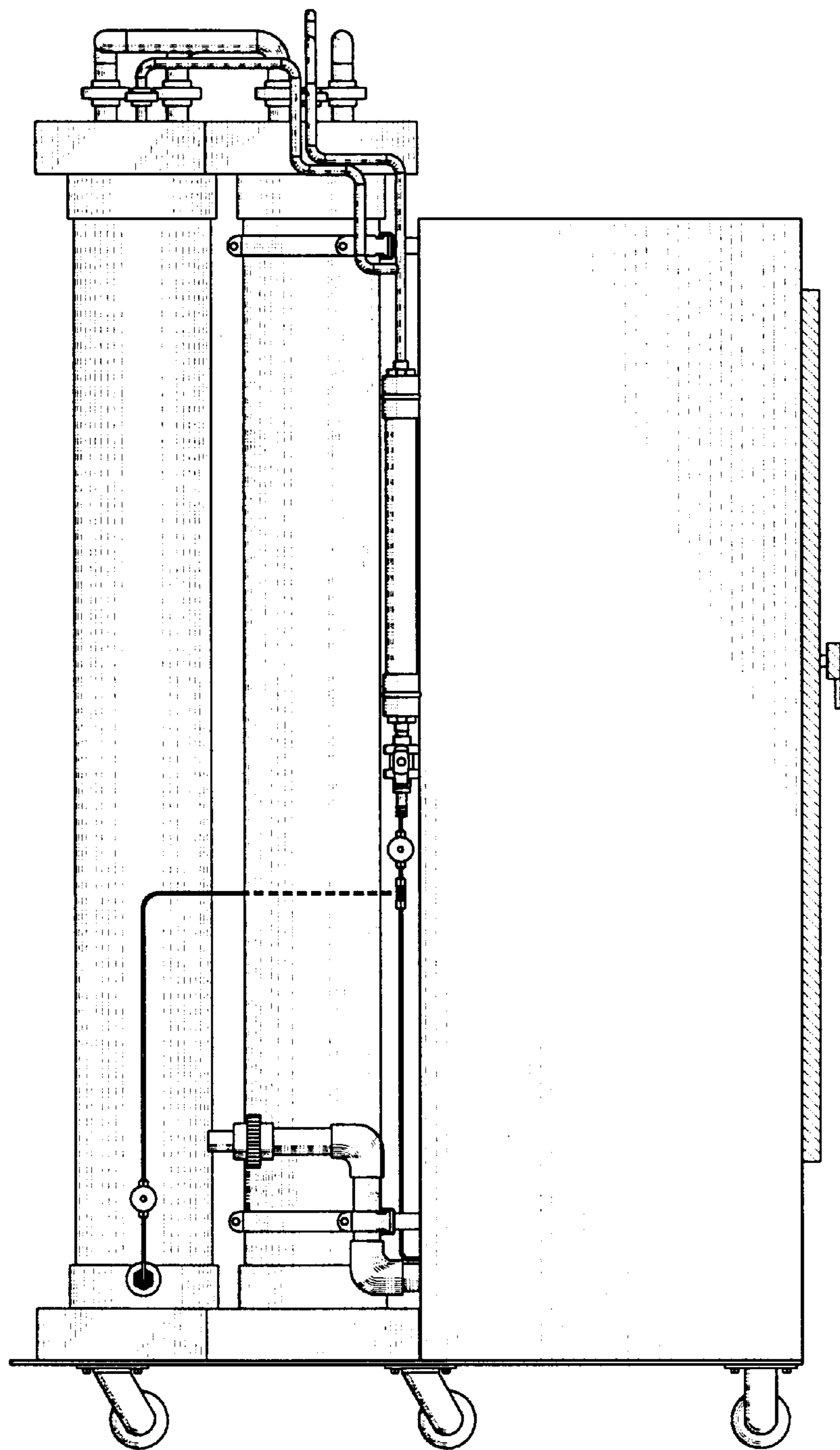

FIG. 6

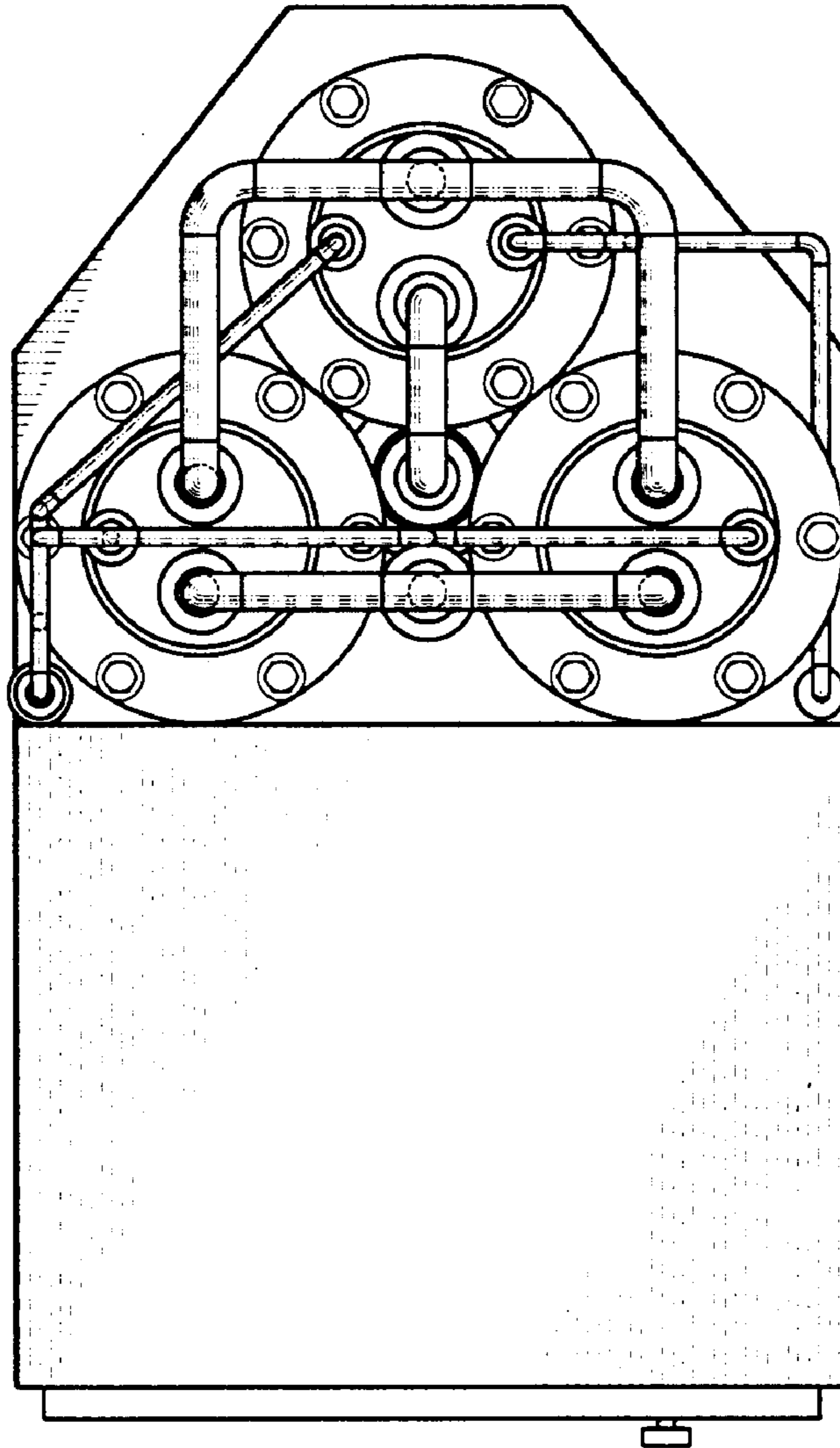

FIG. 7