



US00D420635S

United States Patent [19]

[11] Patent Number: Des. 420,635

Uenohara et al.

[45] Date of Patent: ** Feb. 15, 2000

[54] **DAMPER DISC ASSEMBLY FOR
AUTOMOTIVE RACING APPLICATIONS**

[75] Inventors: **Norihisa Uenohara**, Ibaraki; **Hiroshi Mizukami**, Neyagawa, both of Japan

[73] Assignee: **Exedy Corporation**, Osaka, Japan

[**] Term: **14 Years**

[21] Appl. No.: **29/097,188**

[22] Filed: **Nov. 30, 1998**

[51] **LOC (7) Cl.** **12-16**

[52] **U.S. Cl.** **D12/180**

[58] **Field of Search** D12/180; 188/24.11,
188/344, 18 A, 218 XL, 264 A, 71.1, 71.5,
71.6, 72.3

[56] **References Cited**

U.S. PATENT DOCUMENTS

D. 347,415	5/1994	Rossigno et al.	D12/180
D. 376,783	12/1996	Magalhars	D12/180
D. 381,609	7/1997	Obata	D12/180
D. 402,948	12/1998	Nishimura	D12/180
5,150,774	9/1992	Adamson	188/218 XL
5,190,129	3/1993	Haneda	188/218 XL
5,878,848	3/1999	Zhang	188/218 XL

Primary Examiner—Melody N. Brown
Attorney, Agent, or Firm—Shinju Global Ip Counselors, LLP

[57] **CLAIM**

The ornamental design for a damper disc assembly for automotive racing applications, as shown and described.

DESCRIPTION

FIG. 1 is a front side perspective view illustrating a damper disc assembly for automotive racing applications in accordance with our new design;

FIG. 2 is a front side perspective view illustrating a damper disc assembly for automotive racing applications illustrated in FIG. 1, with a portion of the friction pad broken away to more clearly illustrate our new design;

FIG. 3 is a front side elevational view illustrating a damper disc assembly for automotive racing applications illustrated in FIGS. 1 and 2;

FIG. 4 is a bottom edge elevational view of the damper disc assembly for automotive racing applications of our new design illustrated in FIGS. 1-3;

FIG. 5 is a bottom edge elevational view of the damper disc assembly for automotive racing applications of our new design illustrated in FIGS. 1-4, with a portion of the friction pad broken away to more clearly illustrate our new design;

FIG. 6 is an edge elevational view of the damper disc assembly for automotive racing applications of our new design illustrated in FIGS. 1-5 as viewed along arrow A of FIG. 3;

FIG. 7 is a left edge elevational view of the damper disc assembly for automotive racing applications of our new design illustrated in FIGS. 1-6, with a portion of the friction pad broken away to more clearly illustrate our new design; and,

FIG. 8 is a cross-sectional view of the damper disc assembly for automotive racing applications of our new design illustrated in FIGS. 1-8 as seen along section line 8-8 of FIG. 3.

The bottom edge elevational view of FIG. 4 is identical to the top side elevational view, the right side elevational view and the left side elevational view. The cross-sectional view of FIG. 8 does not form part of the claimed design, but is included to more completely disclose and understand the claimed ornamental design as seen in the remaining figures. The rear side of the damper disc assembly does not form part of the claimed design. The broken line showing of the environment in FIG. 2 is for illustrative purposes only and does not form part of the claimed design.

1 Claim, 6 Drawing Sheets

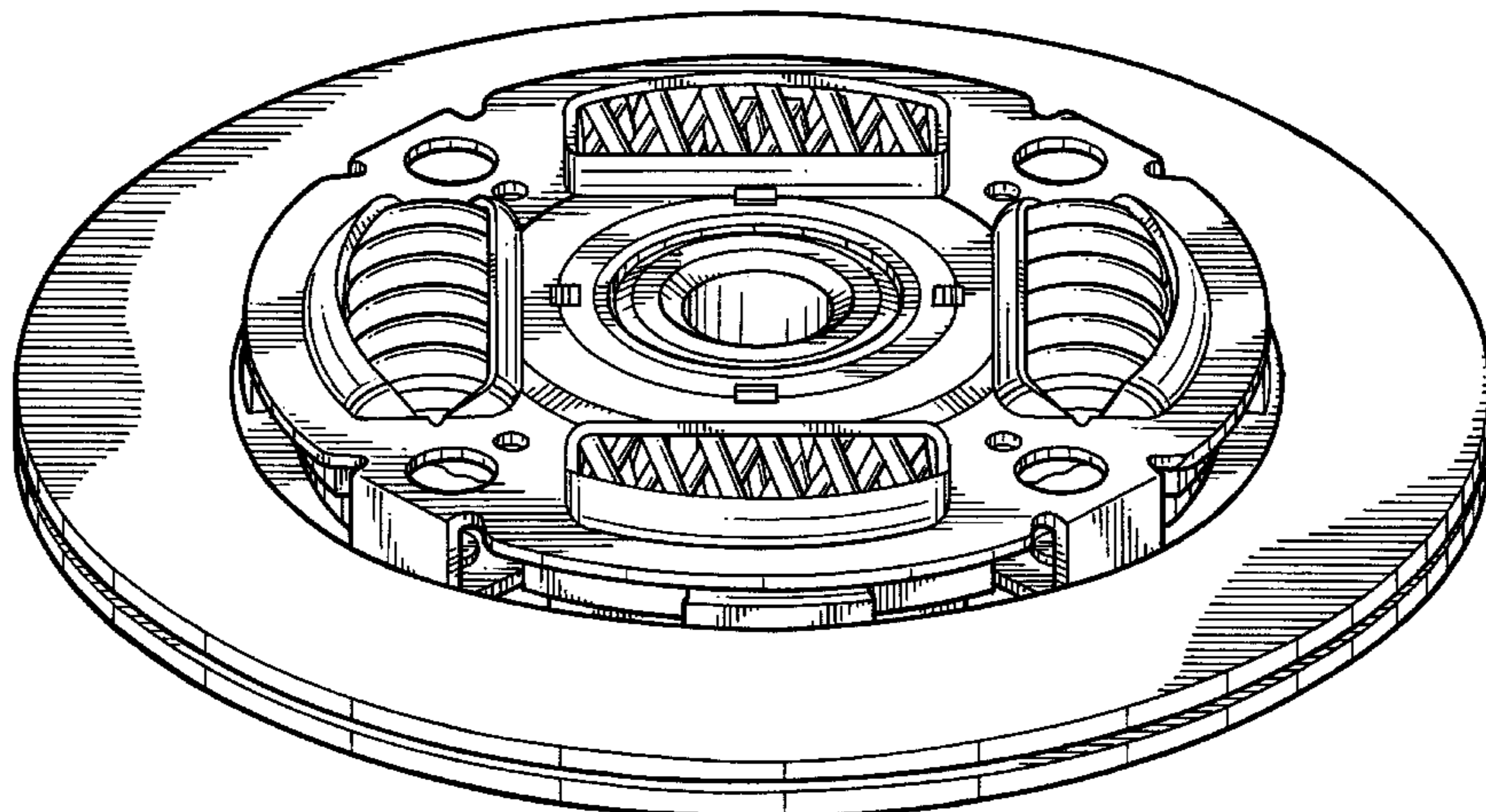

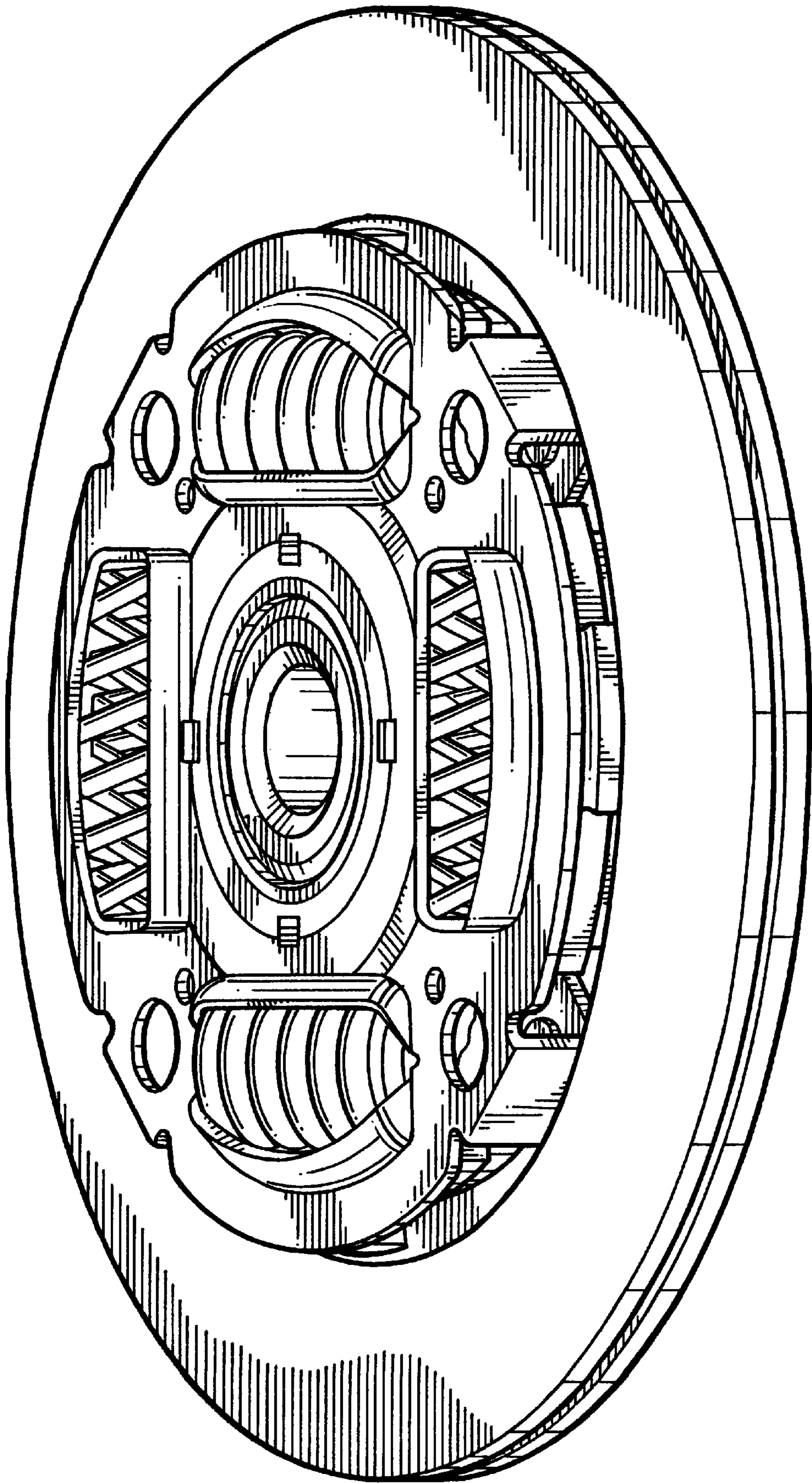

FIG.1

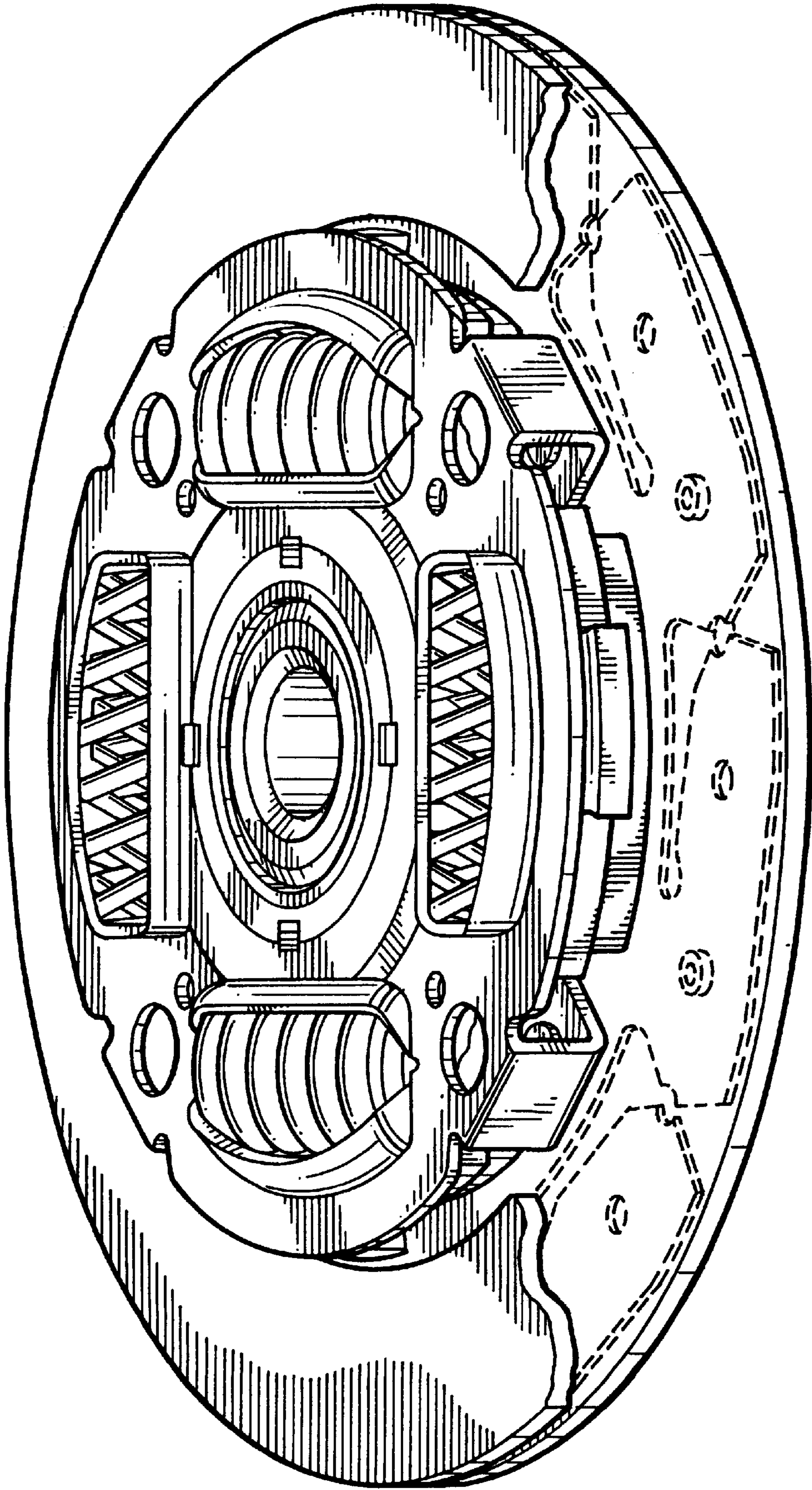

FIG. 2

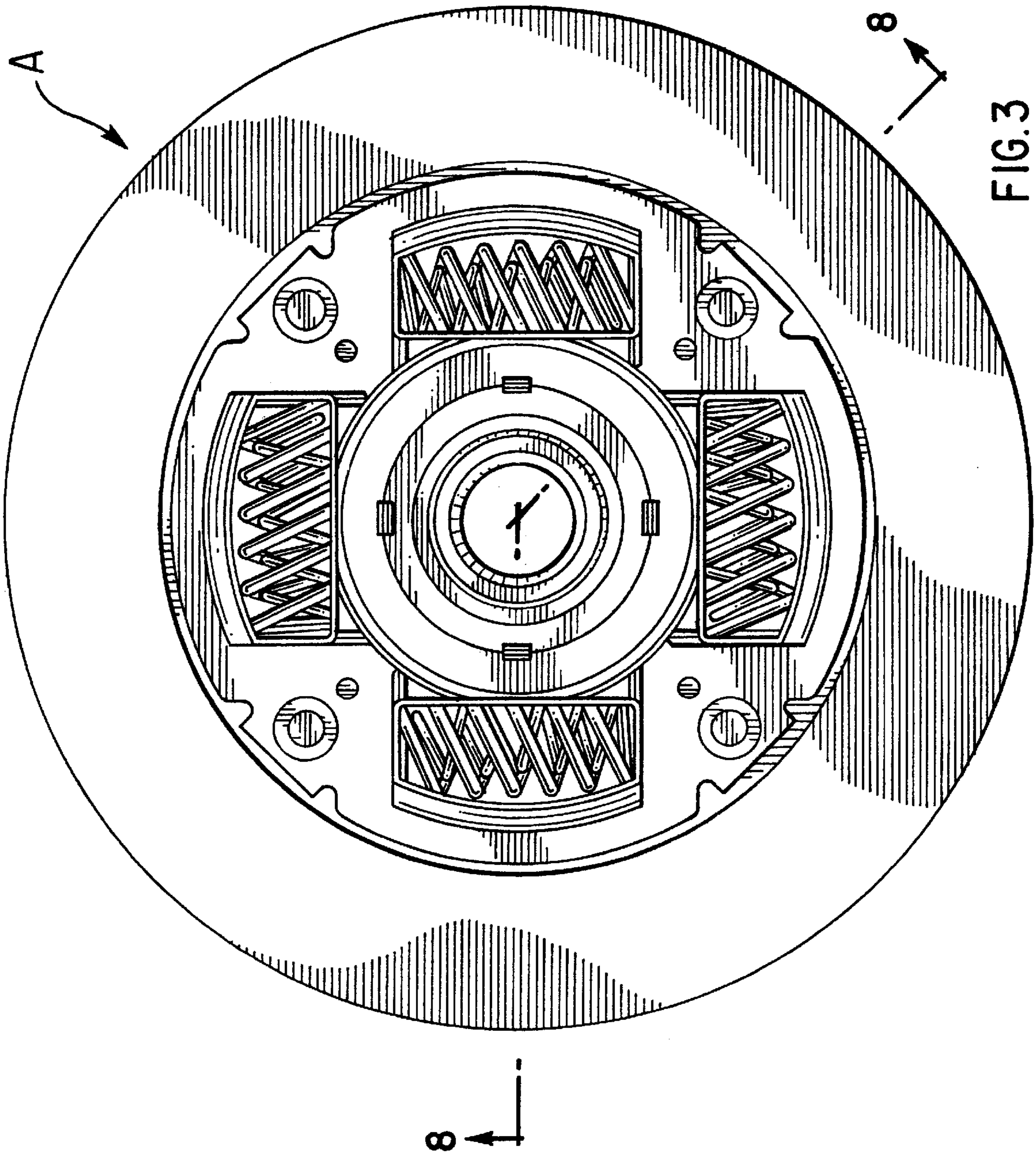

FIG. 3

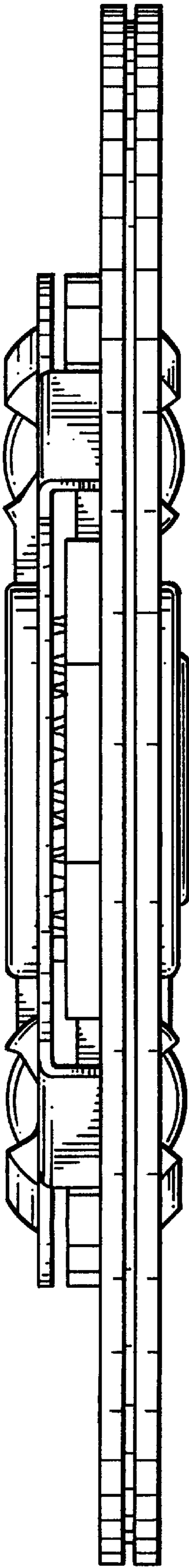

FIG. 4

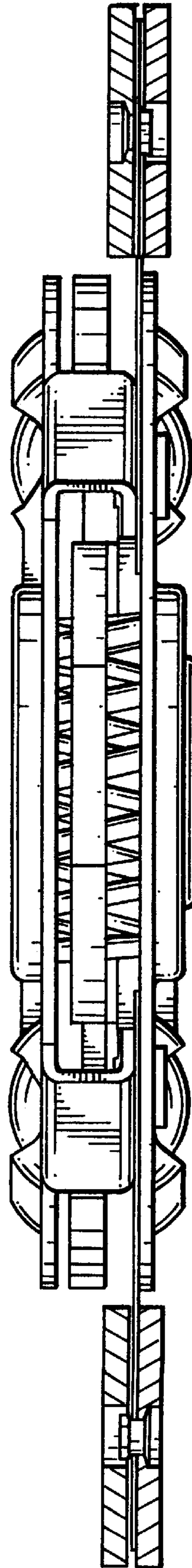

FIG. 5

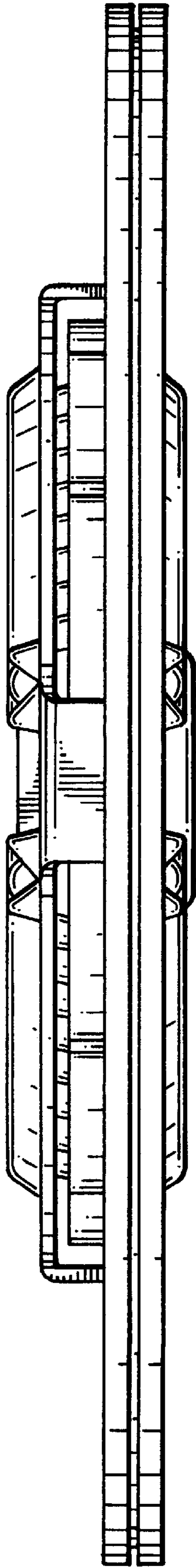

FIG. 6

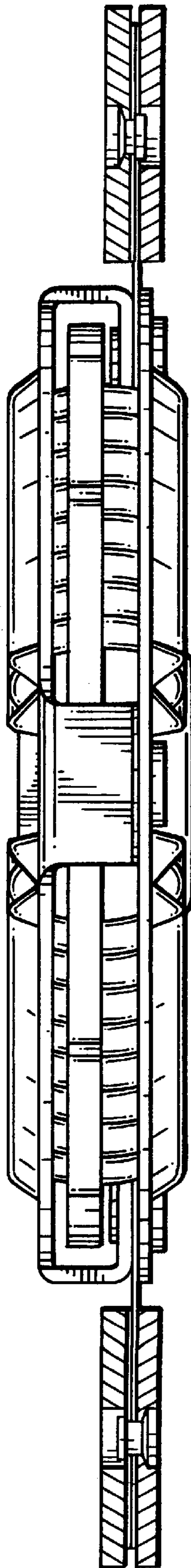

FIG. 7

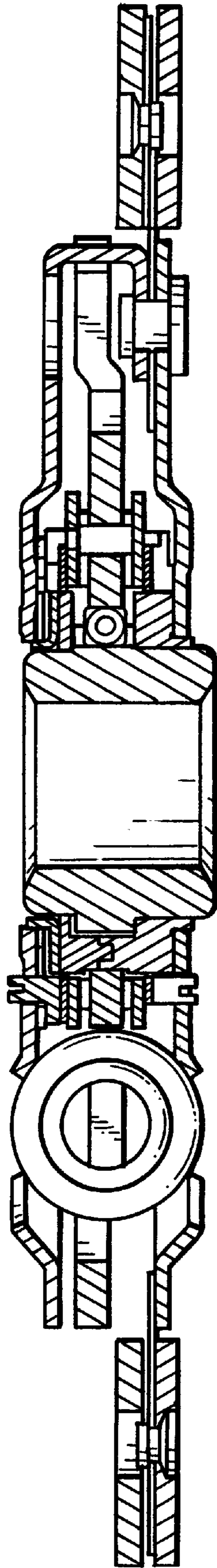

FIG. 8