



US00D420482S

United States Patent [19]

Hultqvist et al.

[11] Patent Number: Des. 420,482

[45] Date of Patent: ** Feb. 8, 2000

[54] LIFTING CARRIAGE

[75] Inventors: **Joachim Hultqvist**, Akersberge; **Kjell Jansson**, Vaxholm; **Lennart Ljunggren**, Sollentuna, all of Sweden

[73] Assignee: **Pronomic AB**, Sweden

[**] Term: **14 Years**

[21] Appl. No.: **29/083,678**

[22] Filed: **Feb. 13, 1998**

[51] LOC (7) Cl. **12-05**

[52] U.S. Cl. **D34/28**

[58] Field of Search D34/28, 29, 33, D34/35, 36, 23; 5/86.1; 254/45, 26; 197/200, 243, 244; 182/152; 414/11, 343, 483; 280/43.12; 180/19.1, 19.2, 19.3

[56] **References Cited**

U.S. PATENT DOCUMENTS

D. 365,907	1/1996	Mishler	D34/28
D. 370,758	6/1996	McCanse	D34/28
D. 384,468	9/1997	Tobias	D34/28

3,394,933	7/1968	Benoit	.
4,538,695	9/1985	Bradt 180/19.2
4,545,085	10/1985	Feldt 5/86.1
4,576,245	3/1986	Oldani 180/19.1 X
4,940,381	7/1990	Rysewyk	.
5,826,857	10/1998	Brack et al.	.

Primary Examiner—Alan P. Douglas
Assistant Examiner—Cynthia E. Ramirez
Attorney, Agent, or Firm—Michaelson & Wallace; Peter L. Michaelson

[57] **CLAIM**

An ornamental design for a lifting carriage, as shown and described.

DESCRIPTION

FIG. 1 is a left view of a lifting carriage according to the teachings of the present invention; FIG. 2 is a right view of the carriage; FIG. 3 is a front view of the carriage; FIG. 4 is a rear view of the carriage; FIG. 5 is a top plan view of the carriage; and, FIG. 6 is a bottom view of the carriage.

1 Claim, 6 Drawing Sheets

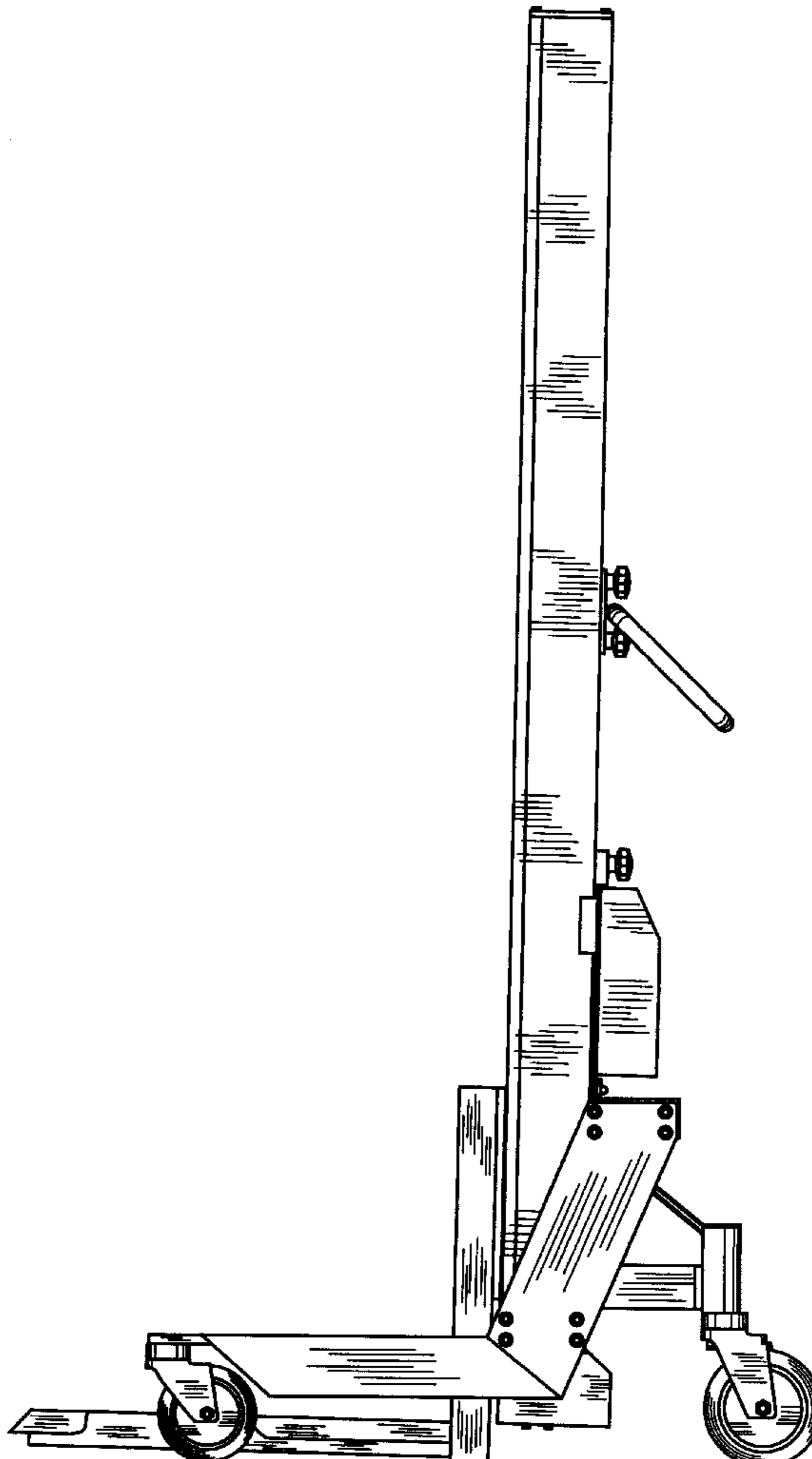

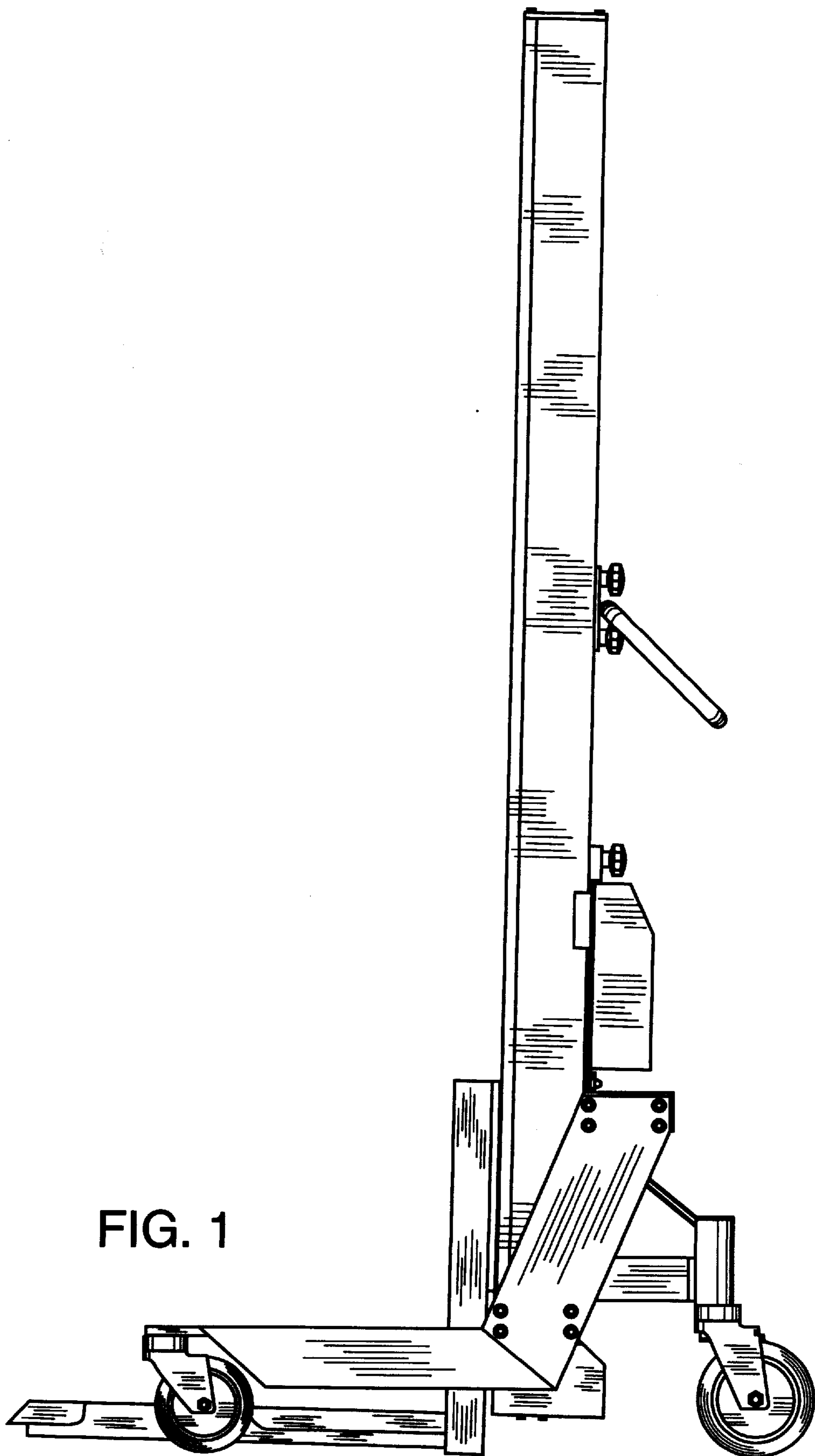

FIG. 1

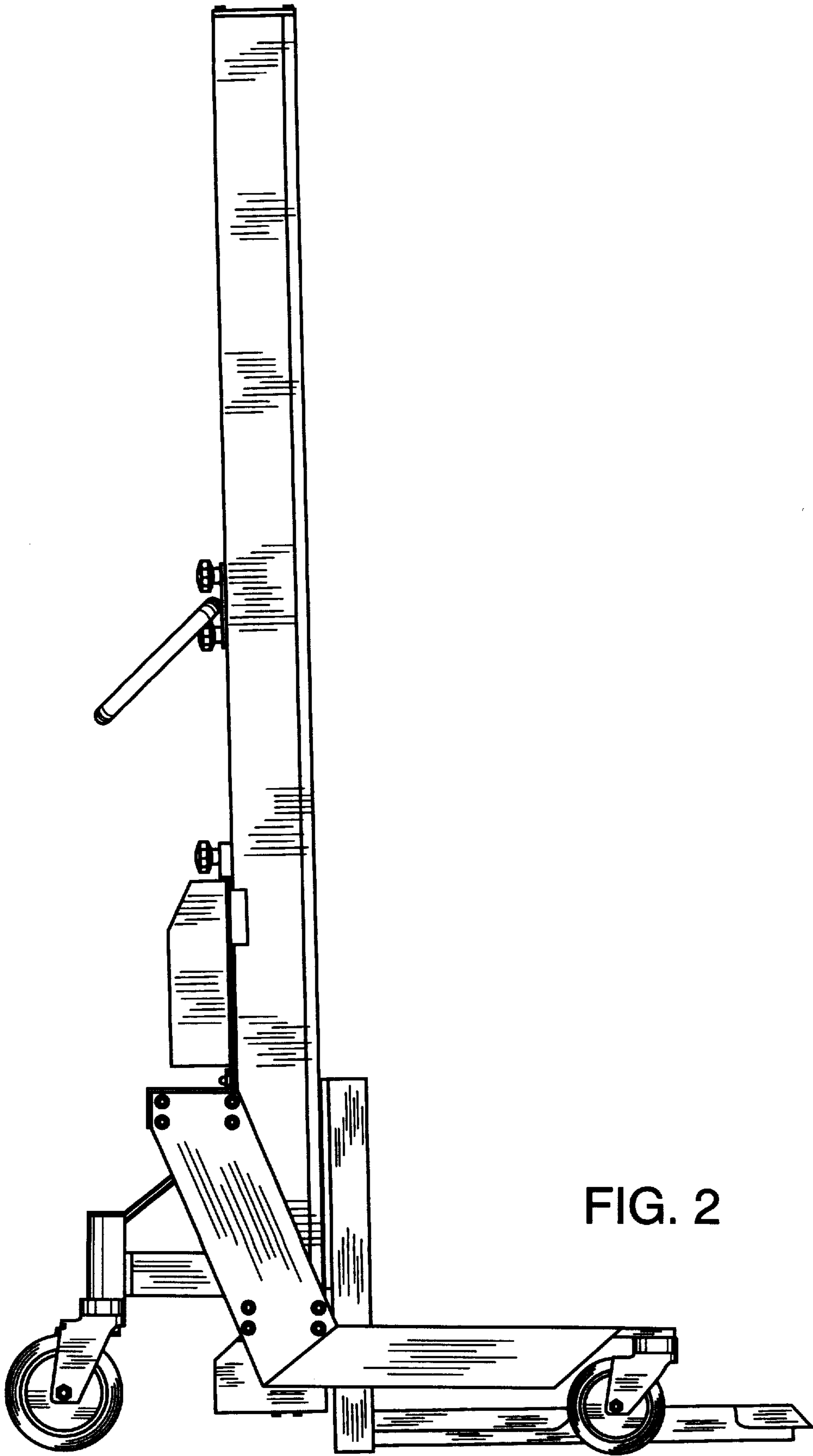

FIG. 2

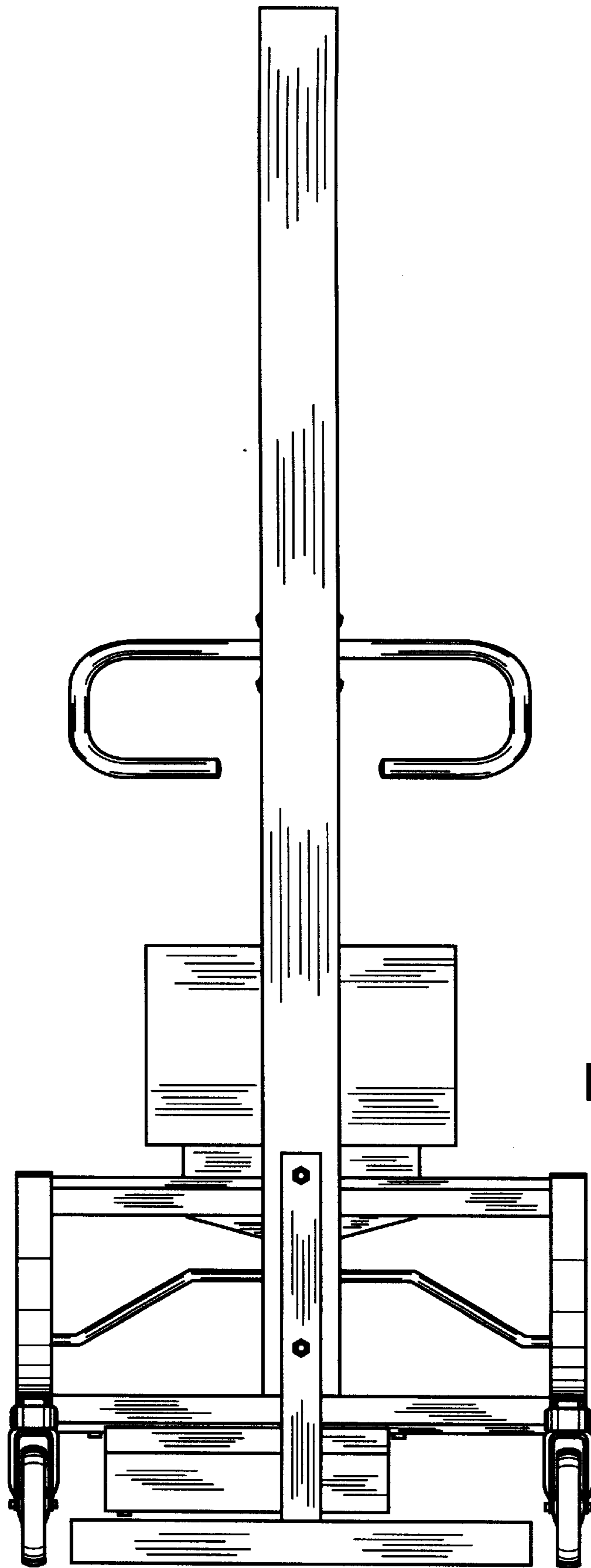

FIG. 3

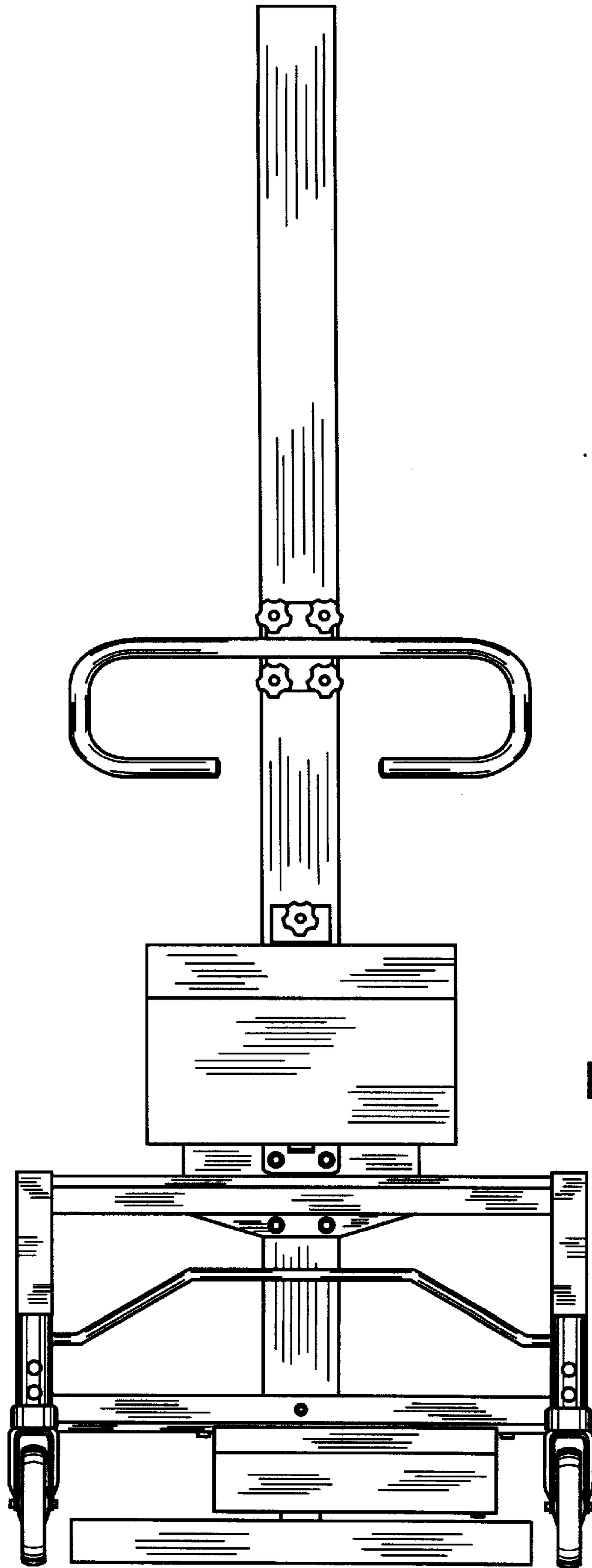

FIG. 4

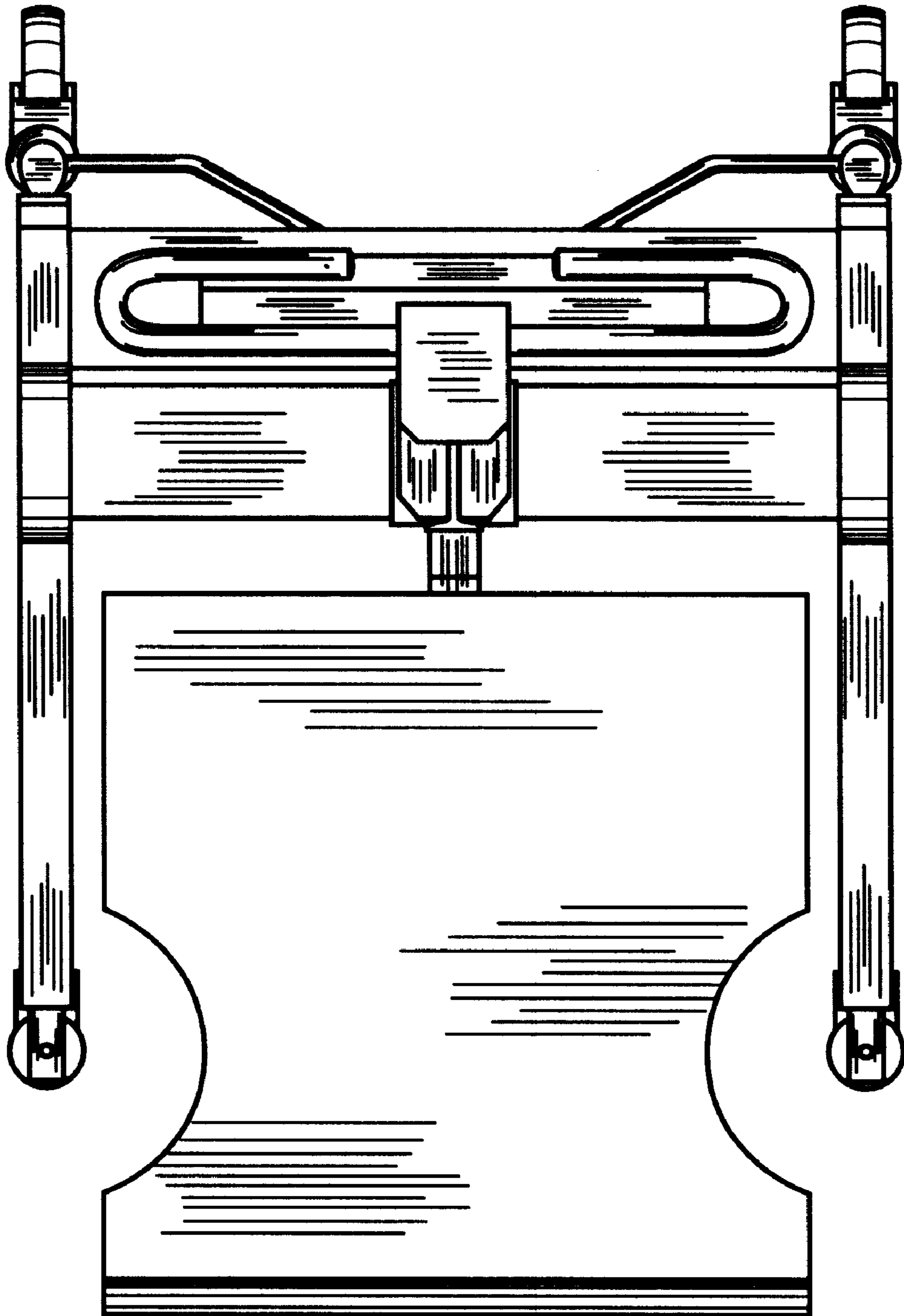

FIG. 5

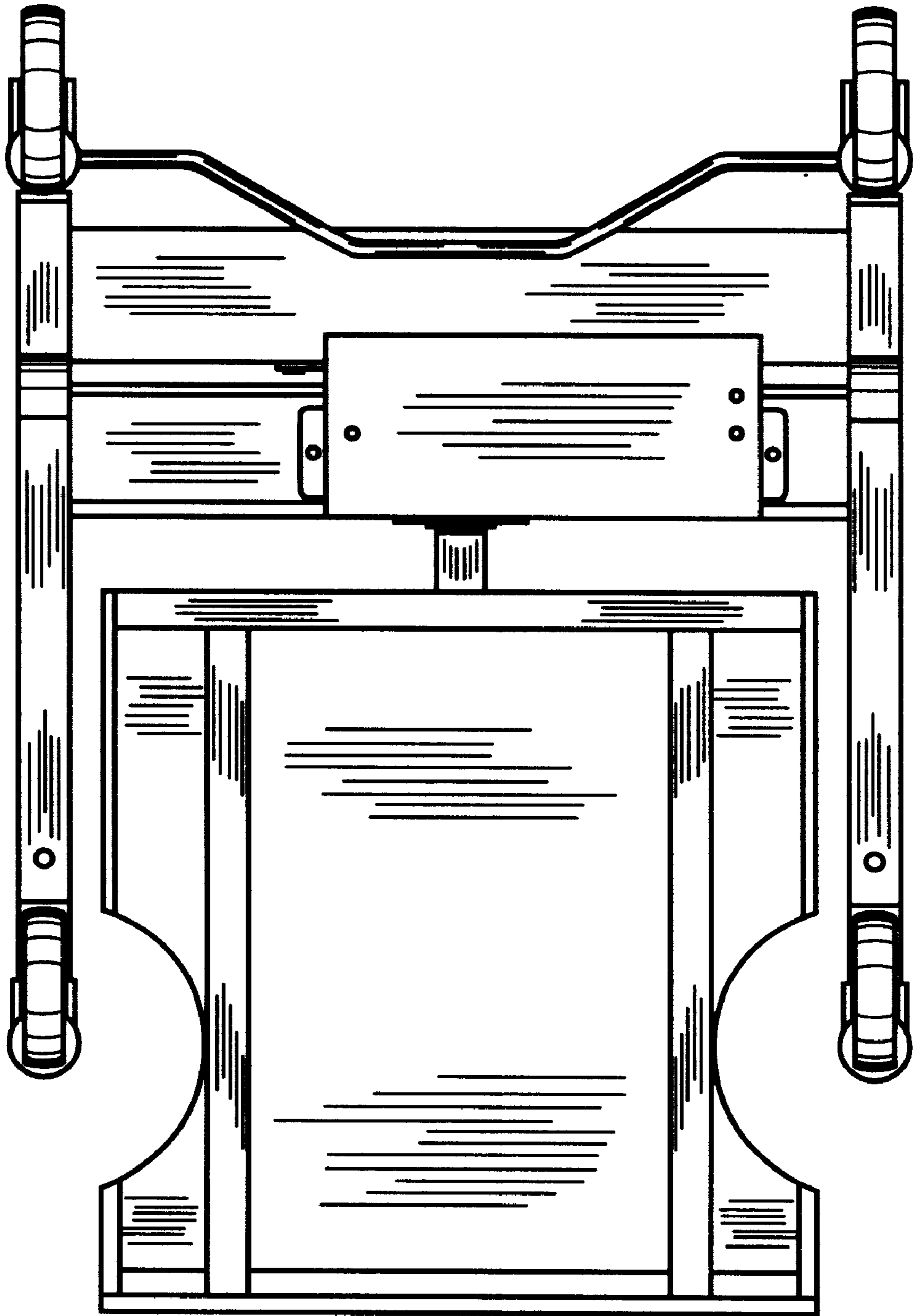

FIG. 6