



US00D420481S

United States Patent [19]

Yates

[11] Patent Number: **Des. 420,481**

[45] Date of Patent: **** Feb. 8, 2000**

[54] **SELF-PROPELLED HAND TRUCK**

3,183,989 5/1965 Trusock et al. 280/43.23
5,716,061 2/1998 Sloan et al. 280/43.23

[76] Inventor: **Denver E Yates**, 6581 47th St. North,
Pinnellas Park, Fla. 33781

Primary Examiner—Kay H. Chin

[**] Term: **14 Years**

[57] **CLAIM**

[21] Appl. No.: **29/097,909**

The ornamental design for a self-propelled hand truck, as shown.

[22] Filed: **Dec. 17, 1998**

DESCRIPTION

[51] **LOC (7) Cl.** **12-02**

FIG. 1 is a front elevational view of the self-propelled hand truck showing my new design;

[52] **U.S. Cl.** **D34/24; D34/26**

FIG. 2 is a back elevational view thereof;

[58] **Field of Search** D34/12-27; 280/43.23,
280/43.12, 47.27, 47.17, 47.21

FIG. 3 is a left side elevational view thereof;

FIG. 4 is a right side elevational view thereof;

FIG. 5 is a top plan view thereof; and,

FIG. 6 is a bottom plan view thereof.

[56] **References Cited**

U.S. PATENT DOCUMENTS

3,119,627 1/1964 Klumb 280/43.23
3,122,381 2/1964 Klemick et al. 280/43.23

1 Claim, 3 Drawing Sheets

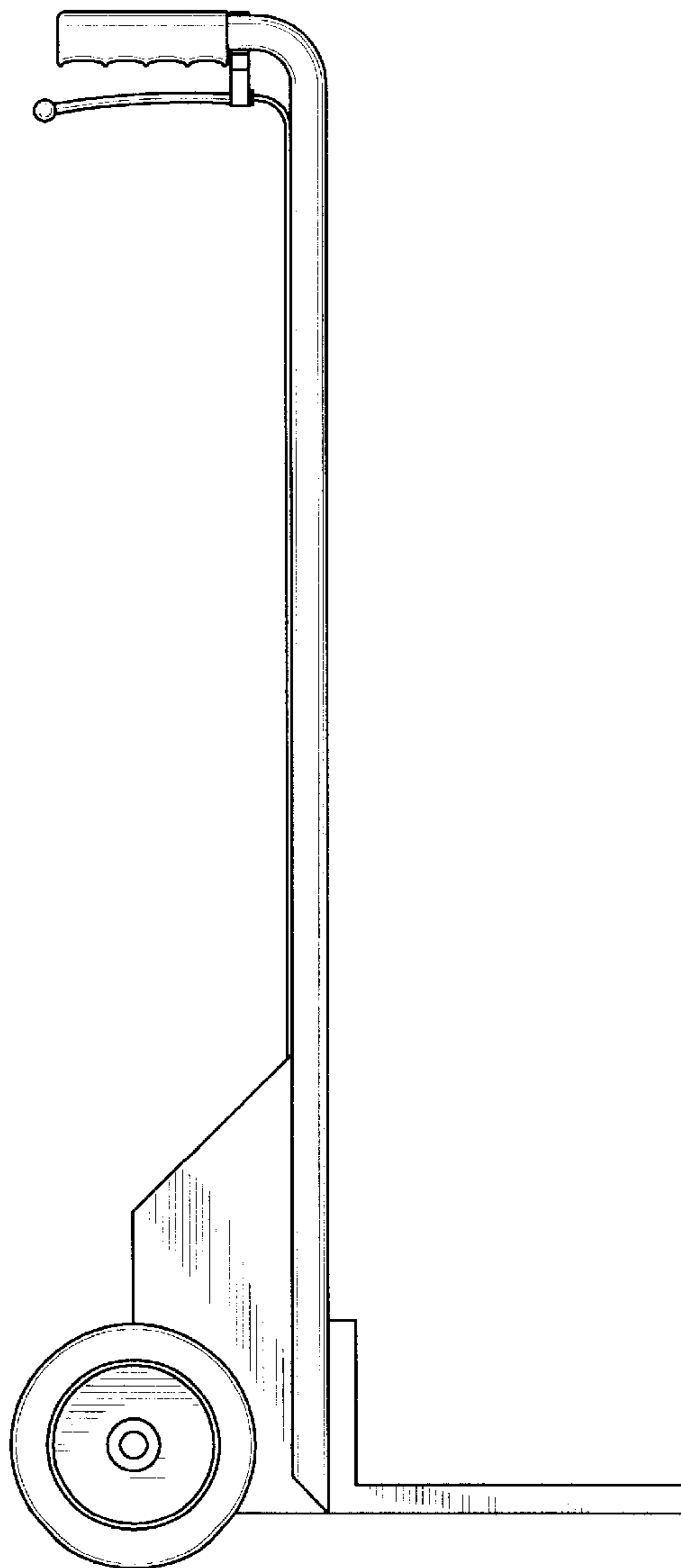
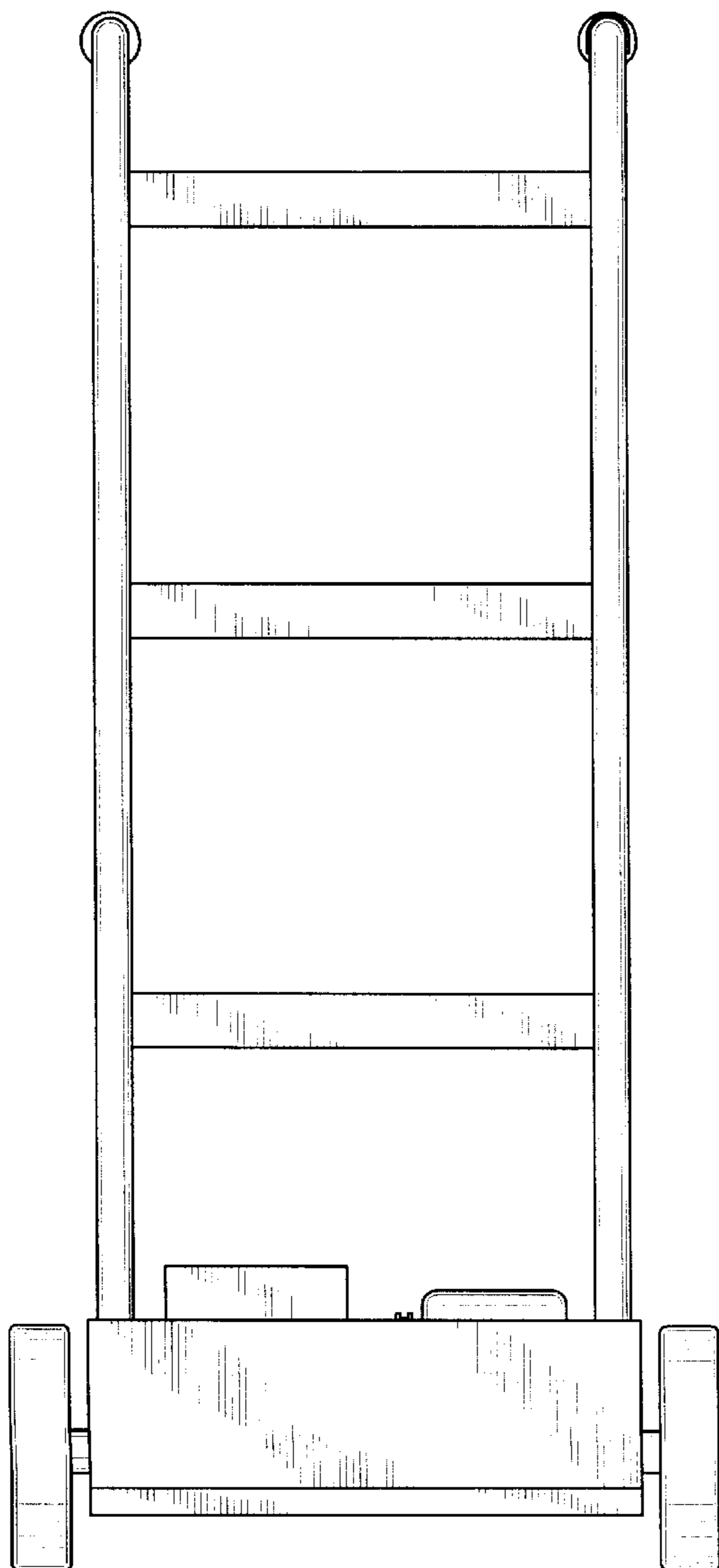

FIG. 1

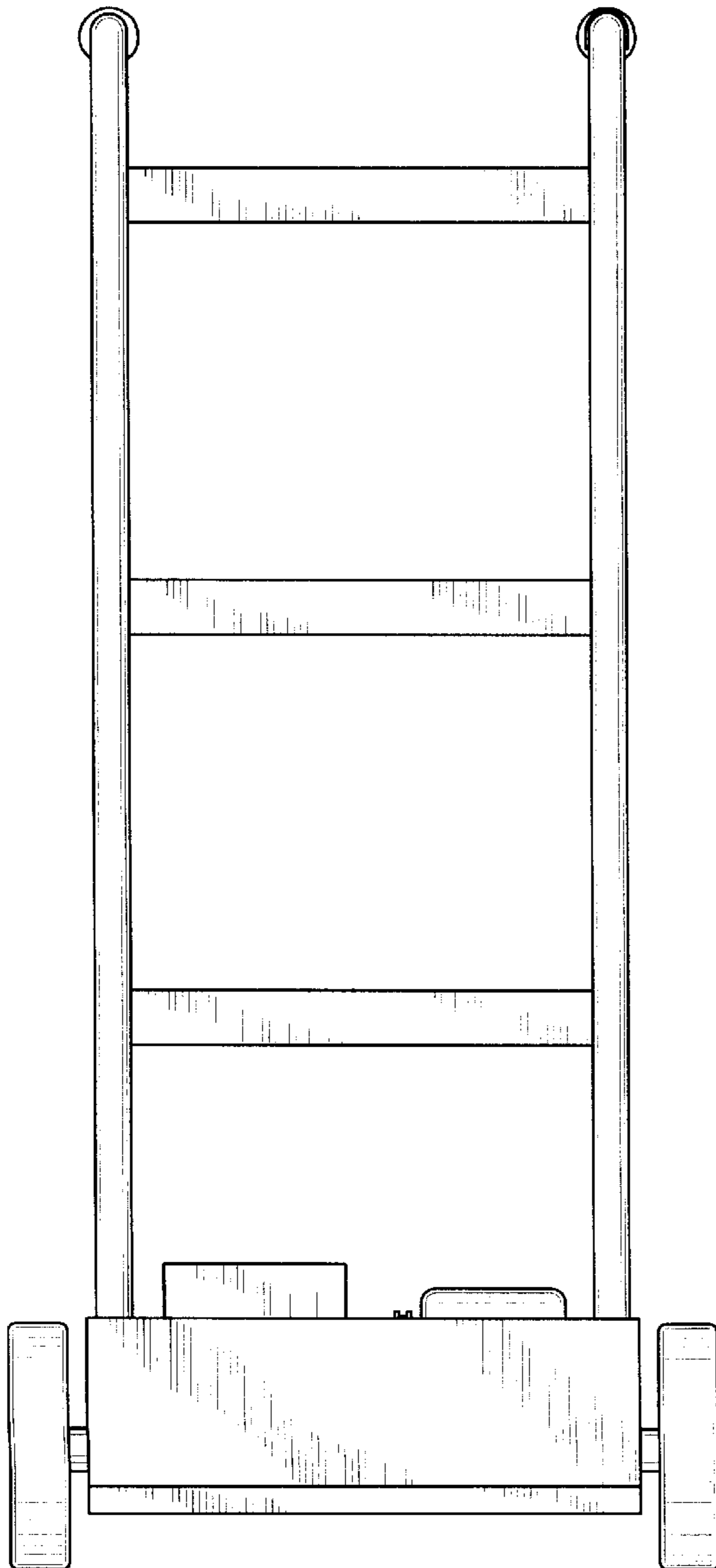
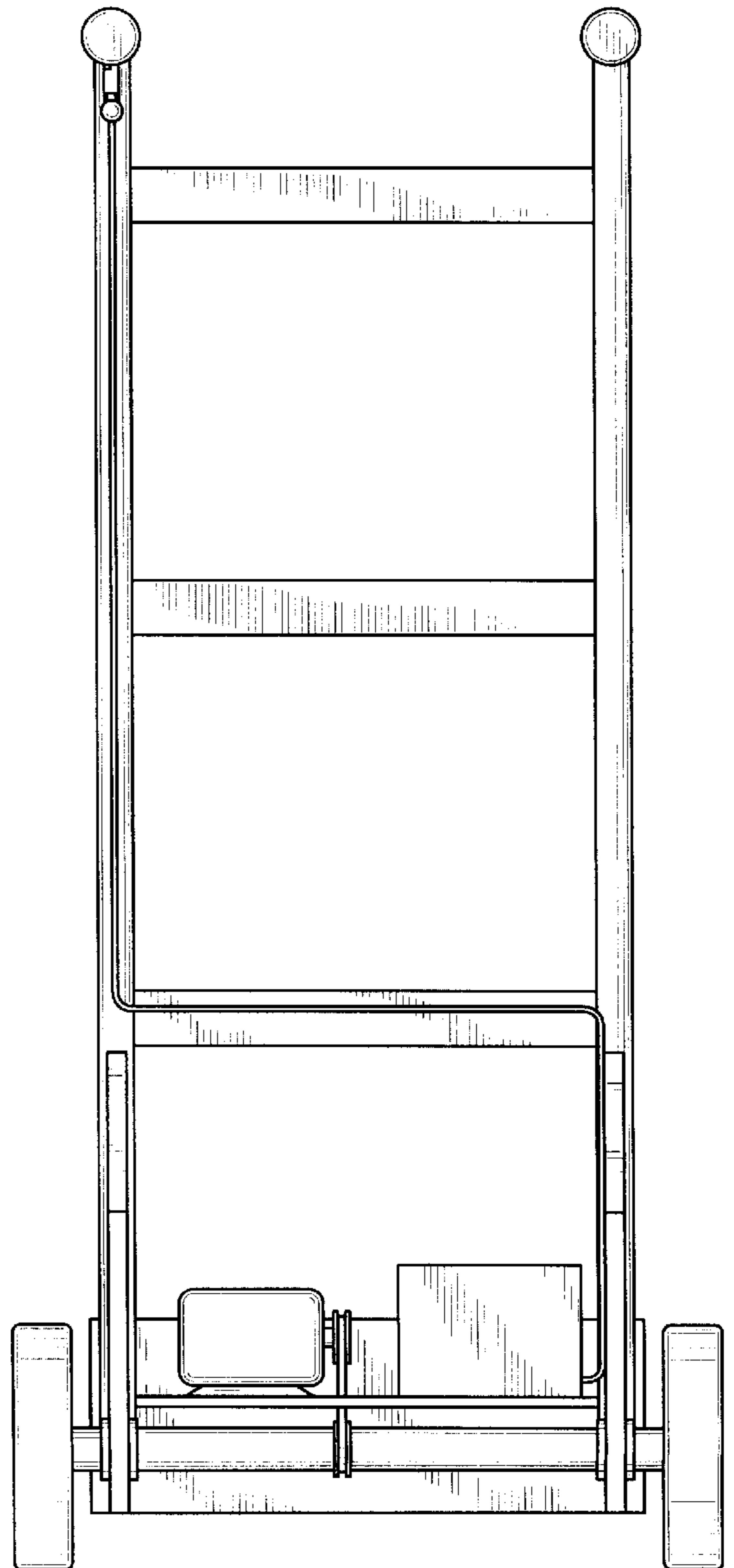

FIG. 2



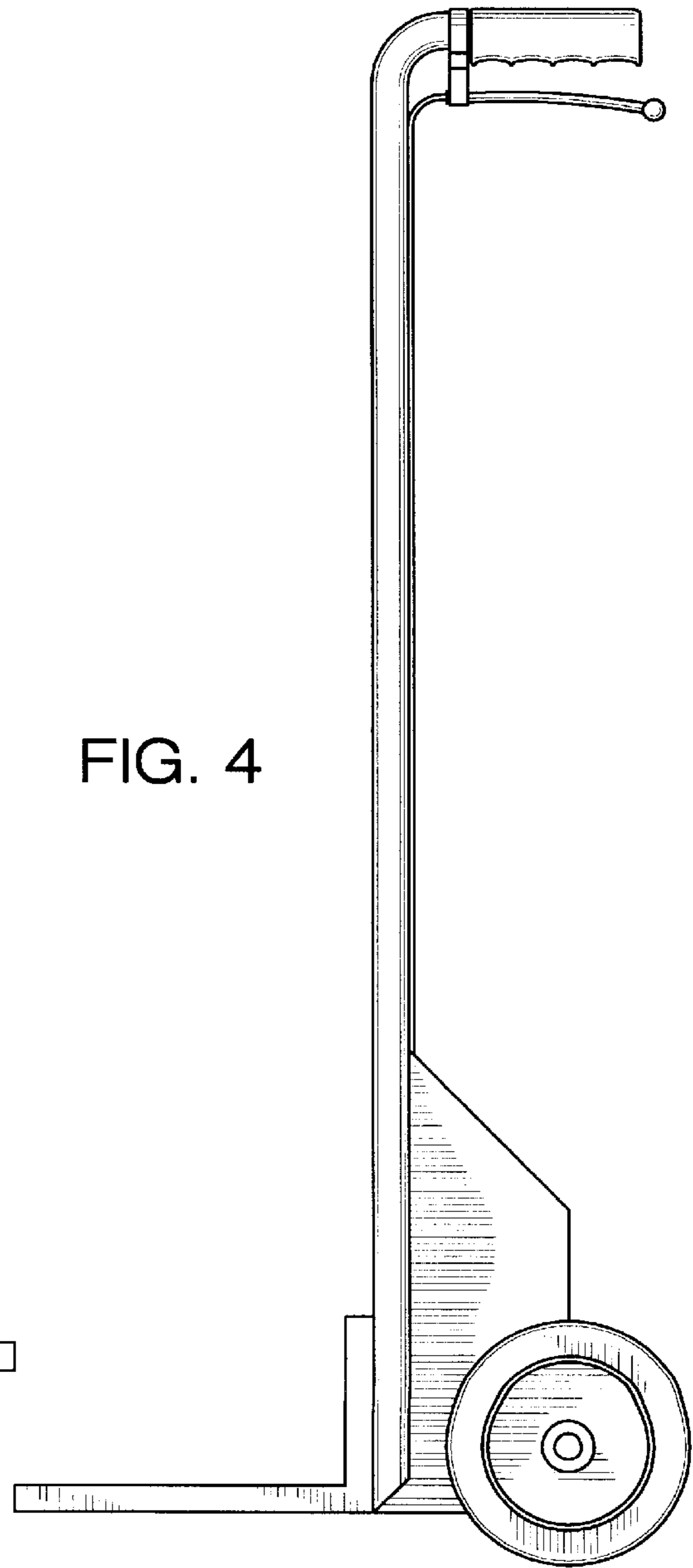
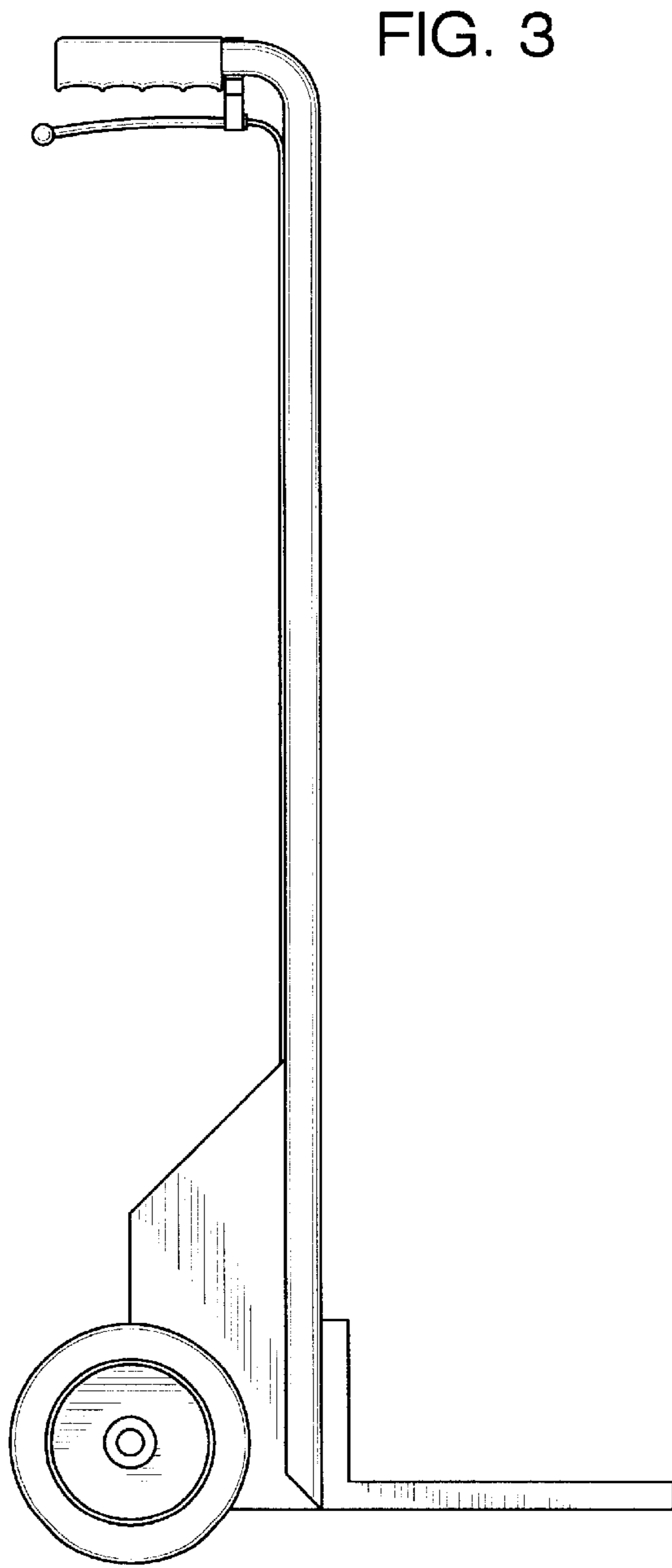

FIG. 5

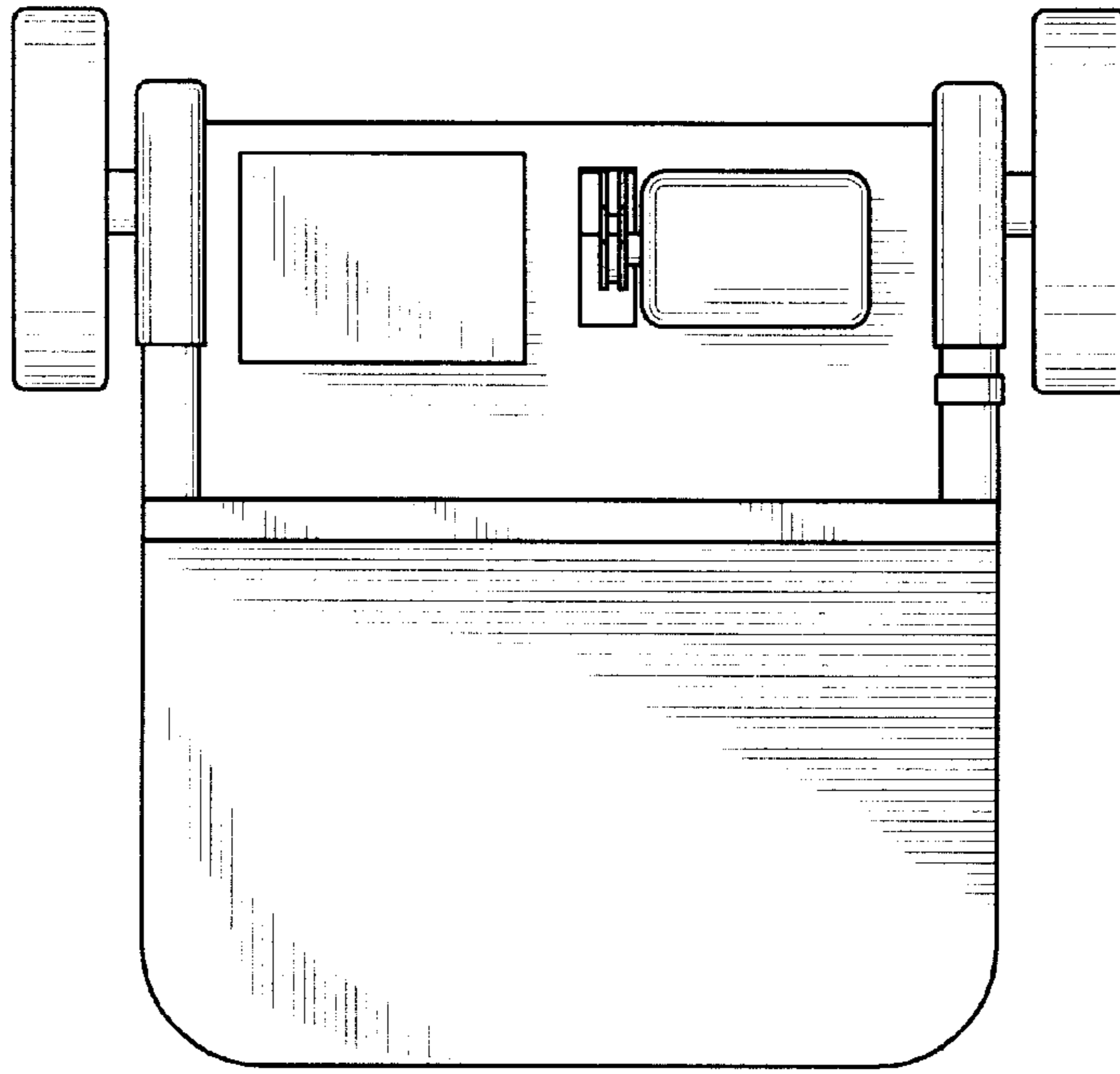

FIG. 6

