



US00D420314S

United States Patent [19]

Kulla et al.

[11] **Patent Number: Des. 420,314**

[45] **Date of Patent: ** Feb. 8, 2000**

[54] **REAR SPOILER OF AN AUTOMOBILE**

D. 339,769 9/1993 Arakawa D12/91
D. 345,135 3/1994 Kaku et al. D12/181

[75] Inventors: **Matthias Kulla**, Stuttgart; **Otto Geffert**, Besigheim, both of Germany

Primary Examiner—Robert M. Spear
Attorney, Agent, or Firm—Evenson, McKeown, Edwards & Lenahan, PLLC

[73] Assignee: **Dr. Ing. h.c.F. Porsche AG**, Weissach, Germany

[**] Term: **14 Years**

[57] CLAIM

The ornamental design for a rear spoiler of an automobile, as shown and described.

[21] Appl. No.: **29/067,390**

[22] Filed: **Feb. 28, 1997**

DESCRIPTION

[51] **LOC (7) Cl.** **12-16**

[52] **U.S. Cl.** **D12/181**

[58] **Field of Search** D12/91, 181, 191,
D12/196, 400; 160/133, DIG. 1; 280/848;
296/82, 180.1, 180.2, 208

FIG. 1 shows a rear elevational view of the rear spoiler of an automobile according to our novel design.

FIG. 2 shows a rear perspective view of the rear spoiler of an automobile according to our novel design;

FIG. 3 shows a side view of the rear spoiler of an automobile according to our novel design, the opposite side view being a mirror image thereof, and;

FIG. 4 shows an enlarged top plan view of the rear spoiler of an automobile according to our novel design.

The broken lines showing a portion of an automobile are for illustration only and form no part of the claimed design.

[56] References Cited

U.S. PATENT DOCUMENTS

D. 154,735 8/1949 Arbib D12/191
D. 239,168 3/1976 Hart D12/181
D. 291,978 9/1987 Parr et al. D12/181
D. 306,849 3/1990 Envall et al. D12/181

1 Claim, 3 Drawing Sheets

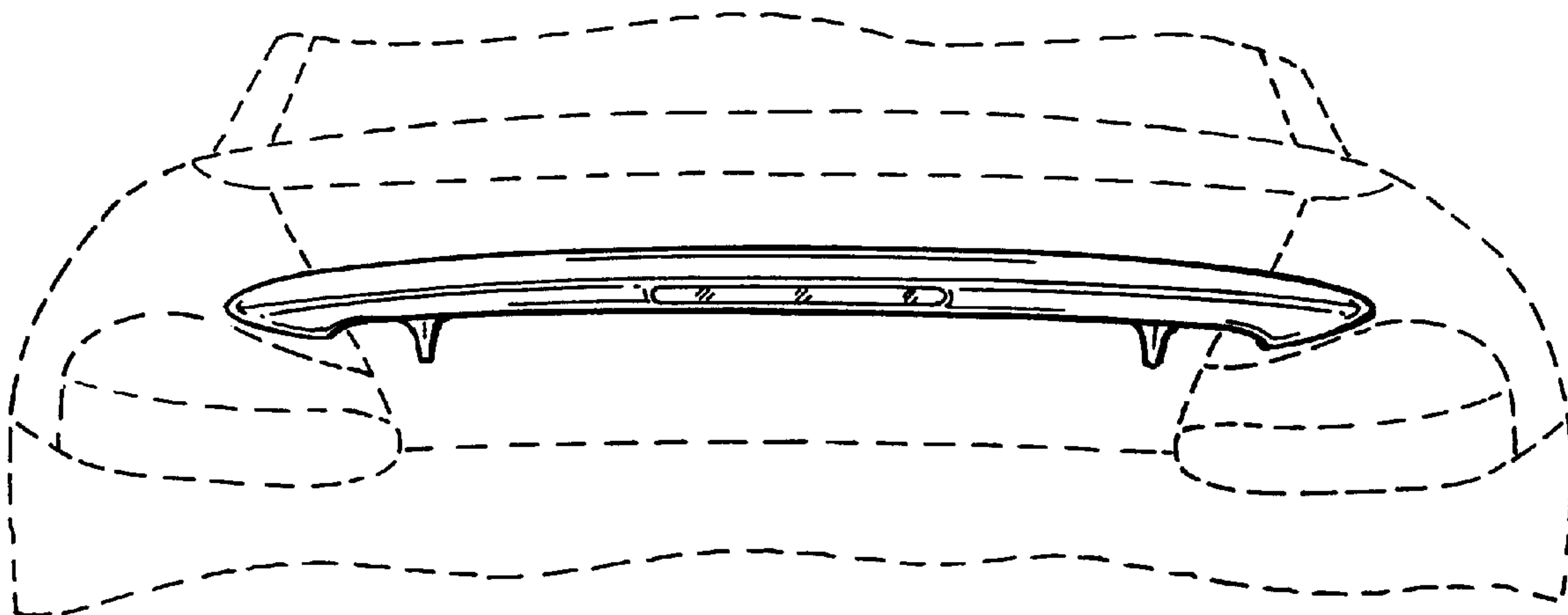

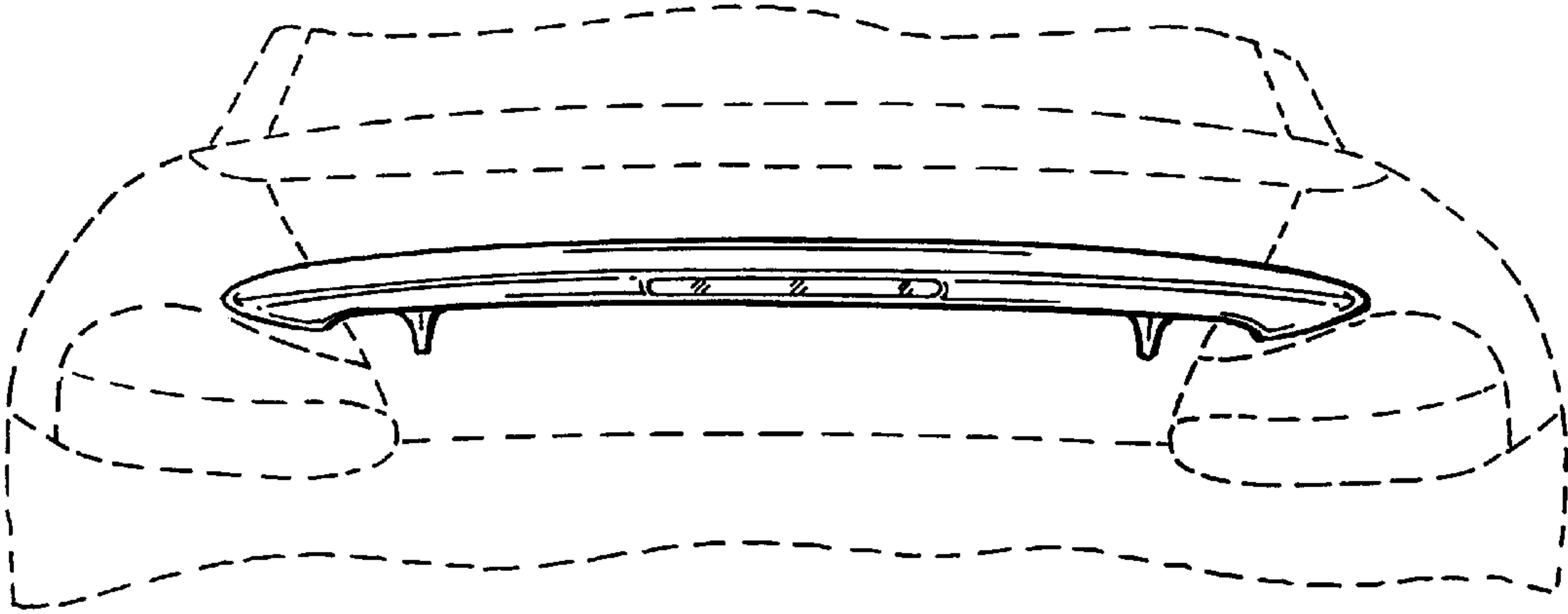

FIG. 1

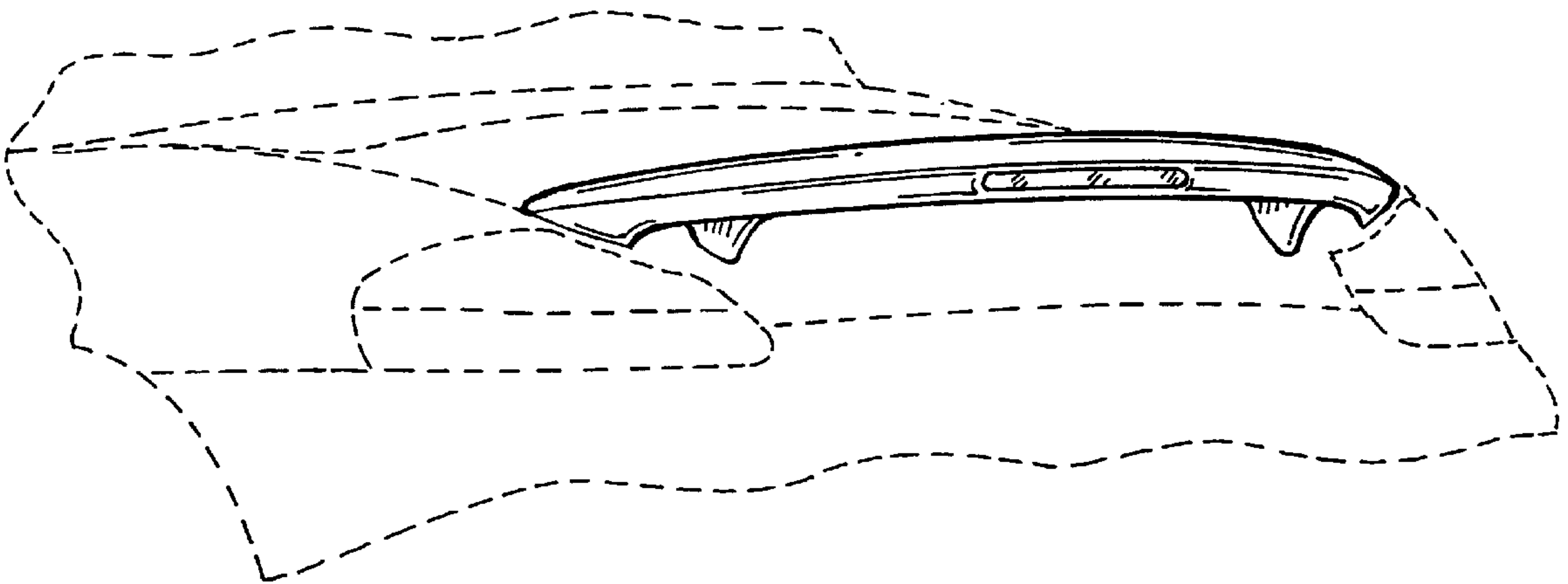

FIG. 2

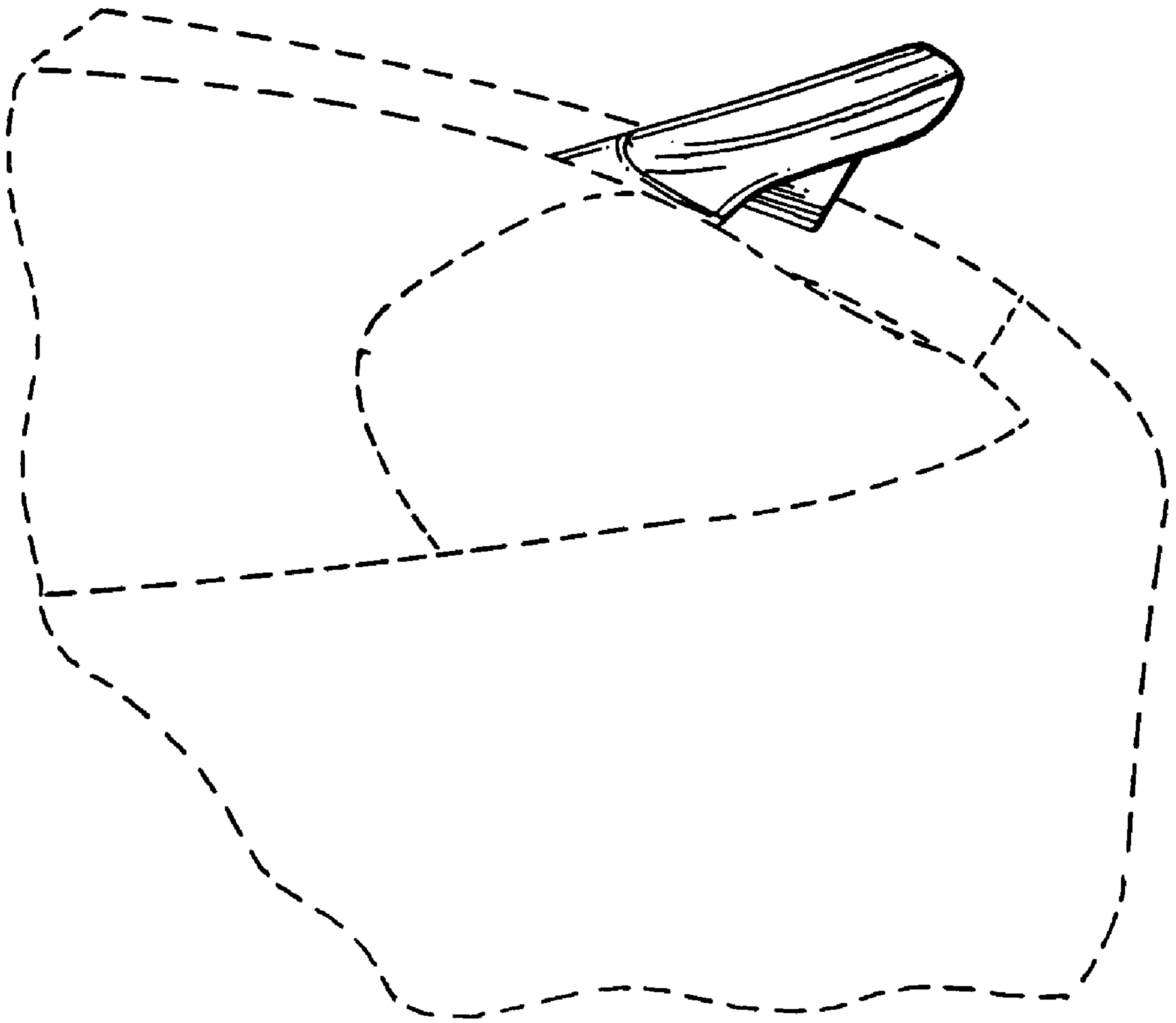

FIG. 3

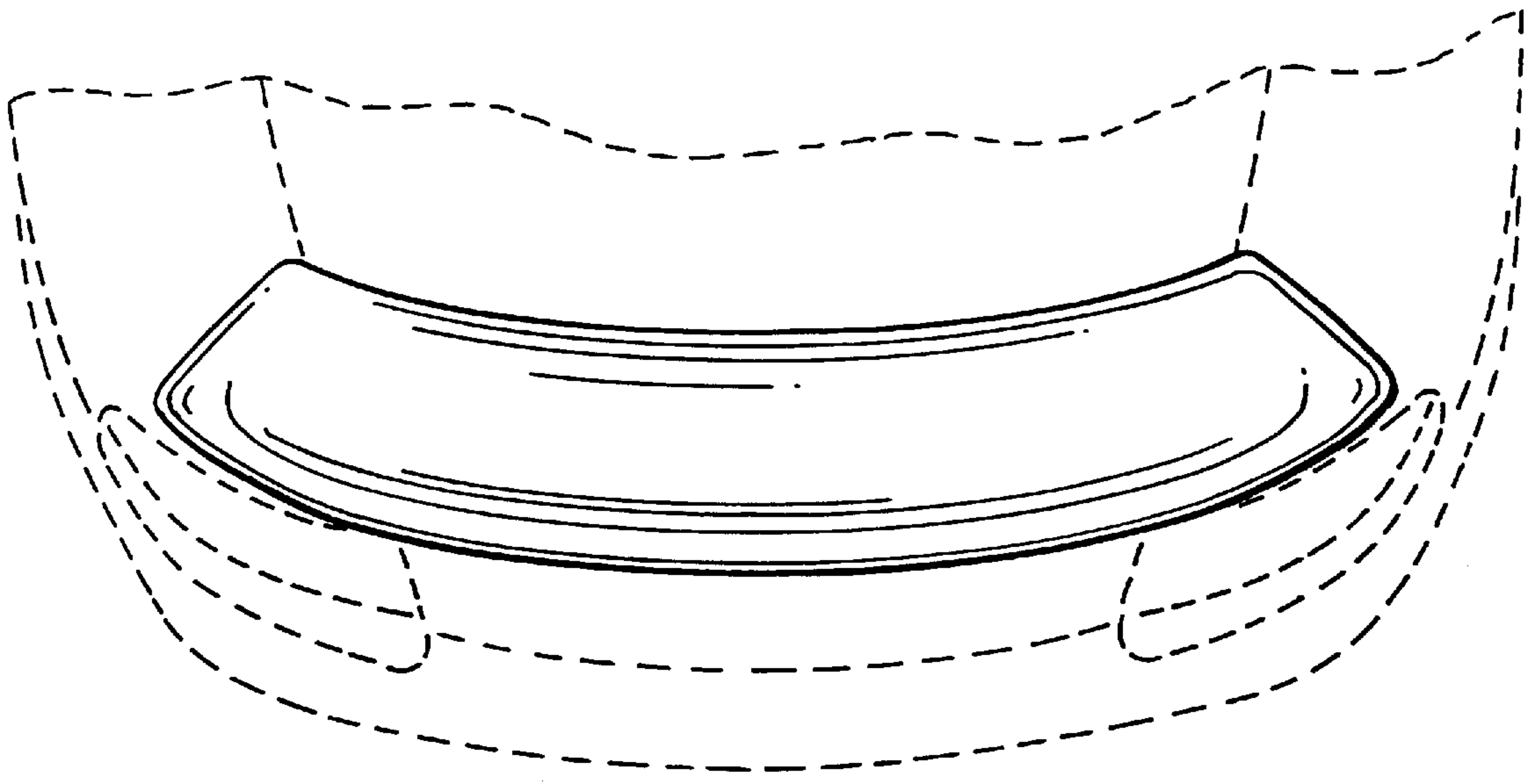

FIG. 4