



US00D420254S

United States Patent [19] Park

[11] **Patent Number: Des. 420,254**

[45] **Date of Patent: ** Feb. 8, 2000**

[54] **DOUBLE MUG FOR USE IN A VEHICLE**

[75] Inventor: **Joo Woong Park**, Seoul, Rep. of Korea

[73] Assignee: **SK Global Co., Ltd.**, Seoul, Rep. of Korea

[**] Term: **14 Years**

[21] Appl. No.: **29/088,895**

[22] Filed: **Jun. 3, 1998**

[51] **LOC (7) Cl. 07-01**

[52] **U.S. Cl. D7/510; D7/511; D7/533**

[58] **Field of Search** D7/507, 509, 513, D7/510, 511, 608, 619, 622, 624, 523, 533, 536, 514, 575, 625, 512, 532, 605; 220/669, 737, 673, 675, 672, 630, 729, 715; 215/227; D12/419, 415

[56] **References Cited**

U.S. PATENT DOCUMENTS

D. 214,458	6/1969	Riley	D7/533
D. 369,063	4/1996	Meisner	D7/533
D. 384,860	10/1997	Trombly	D7/536
D. 386,948	12/1997	Wissinger	D7/533
D. 387,620	12/1997	Trombly	D7/510
D. 396,777	8/1998	Inoue	D7/511

D. 398,187	9/1998	Parker	D7/510
D. 406,011	2/1999	Hatsumoto et al.	D7/510
2,895,636	7/1959	Martin	D7/536
3,847,311	11/1974	Flores et al.	220/737 X
4,040,549	8/1977	Sadler	D7/536 X
5,531,353	7/1996	Ward et al.	220/729

Primary Examiner—M. N. Pandozzi
Attorney, Agent, or Firm—Watson Cole Grindle Watson, P.L.L.C.

[57] **CLAIM**

The ornamental design for a double mug for use in a vehicle, as shown and described.

DESCRIPTION

FIG. 1 is a perspective view of a double mug for use in a vehicle showing my new design;
FIG. 2 is a top plan view thereof;
FIG. 3 is a bottom plan view thereof;
FIG. 4 is a front view thereof;
FIG. 5 is a rear view thereof;
FIG. 6 is a left side view thereof;
FIG. 7 is a right side view thereof;
FIG. 8 is a section view along line A—A of FIG. 4; and,
FIG. 9 is a exploded view of the mug of FIG. 1.

1 Claim, 5 Drawing Sheets

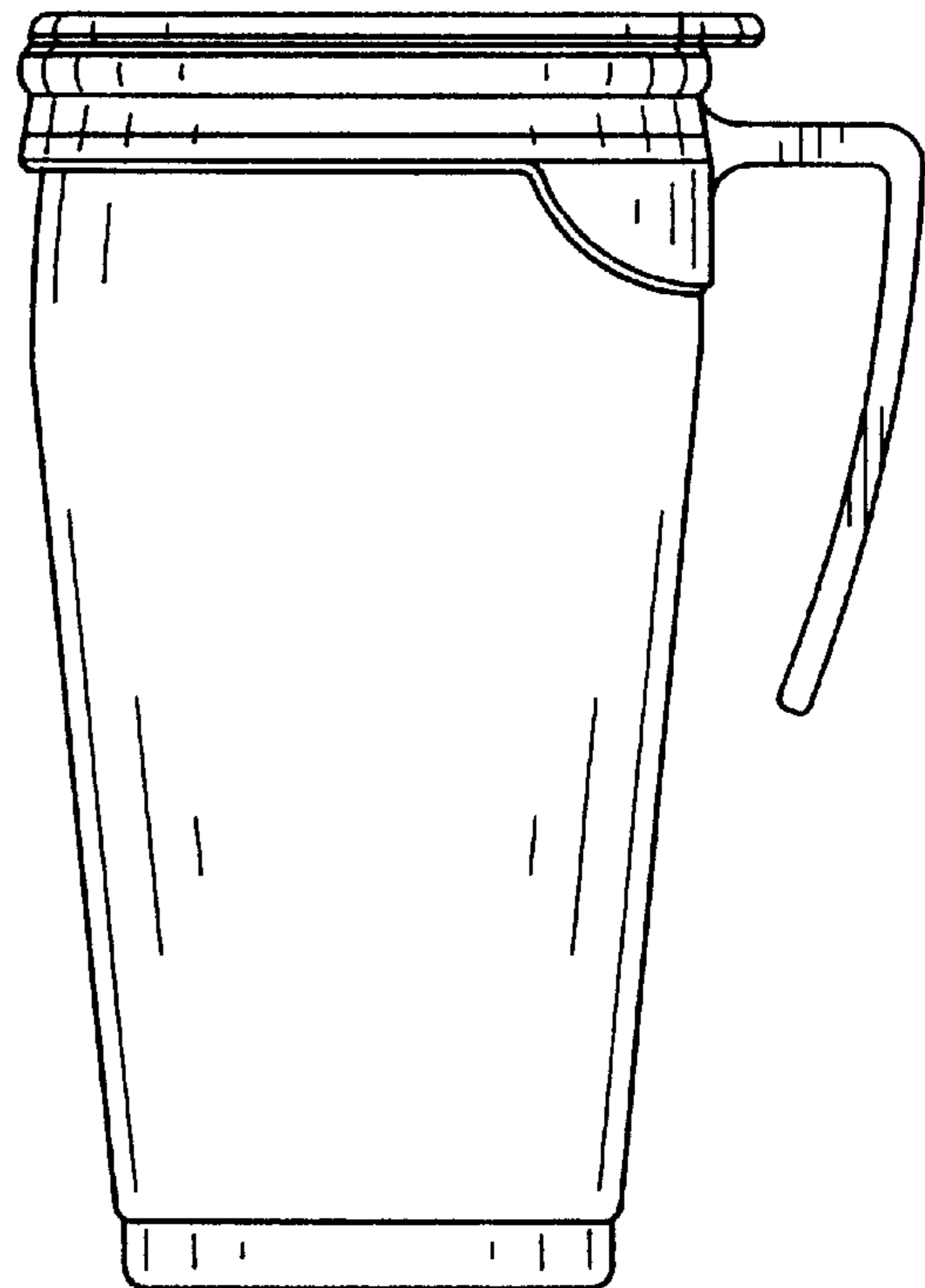
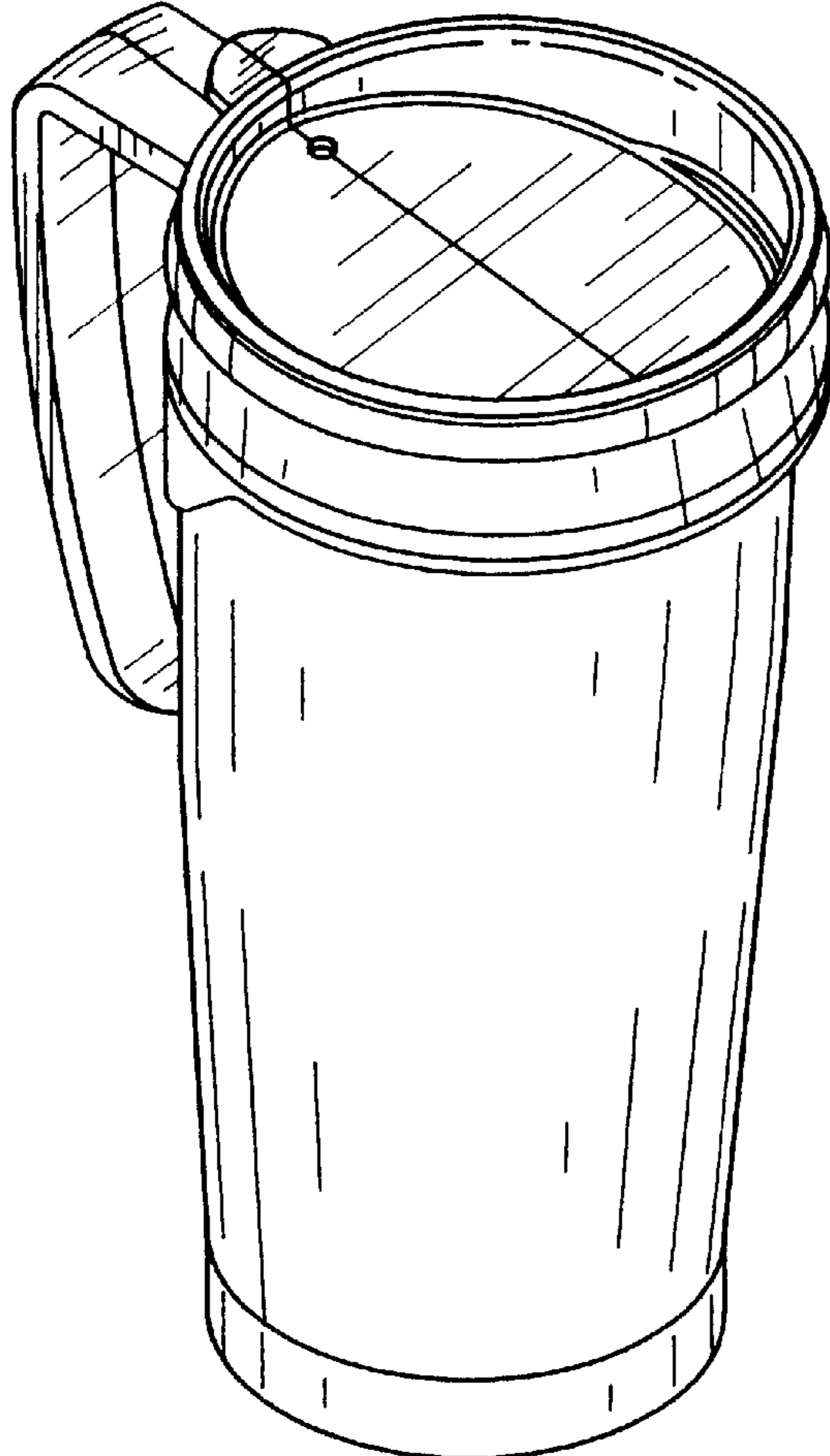

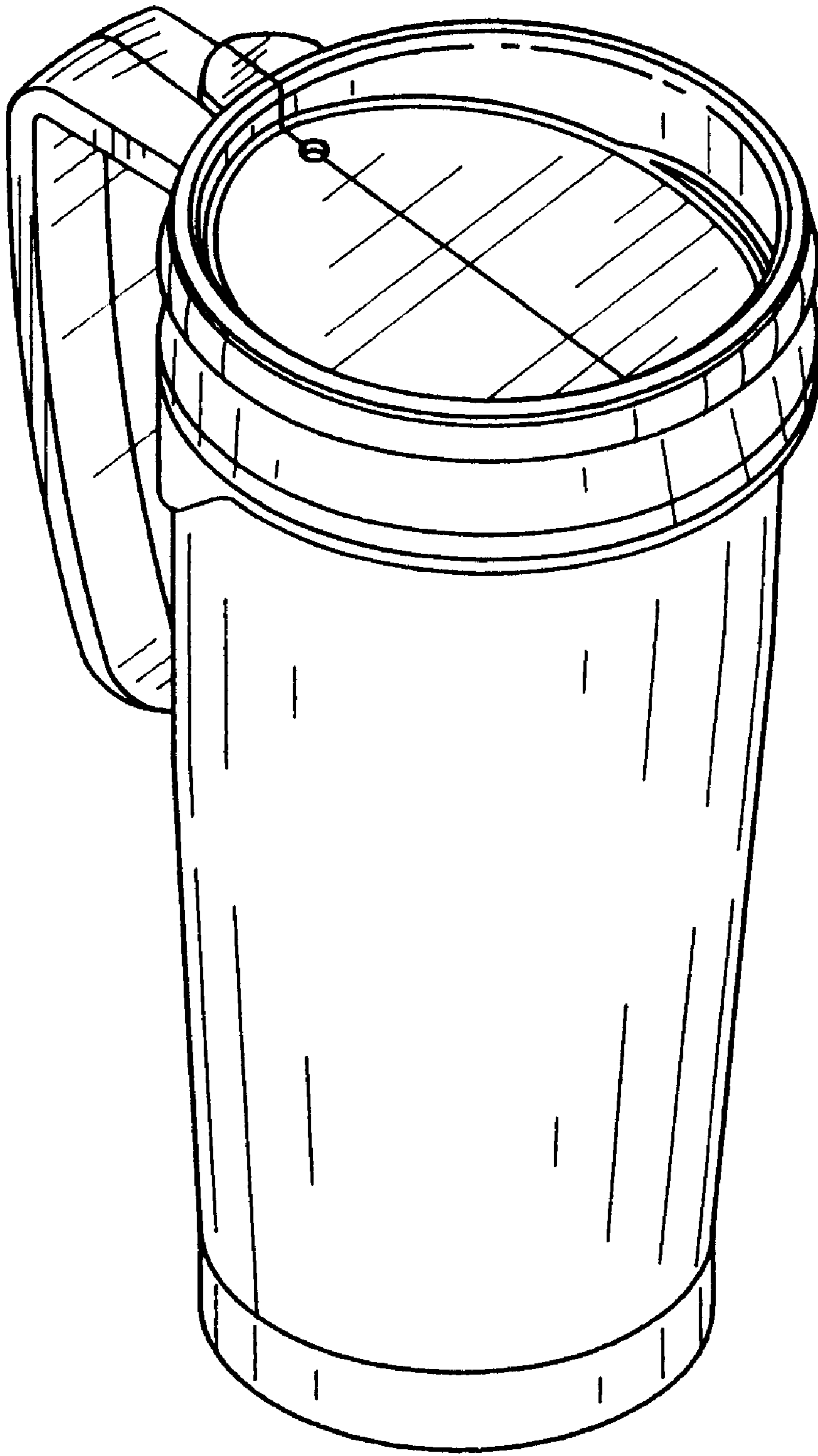

FIG. 1

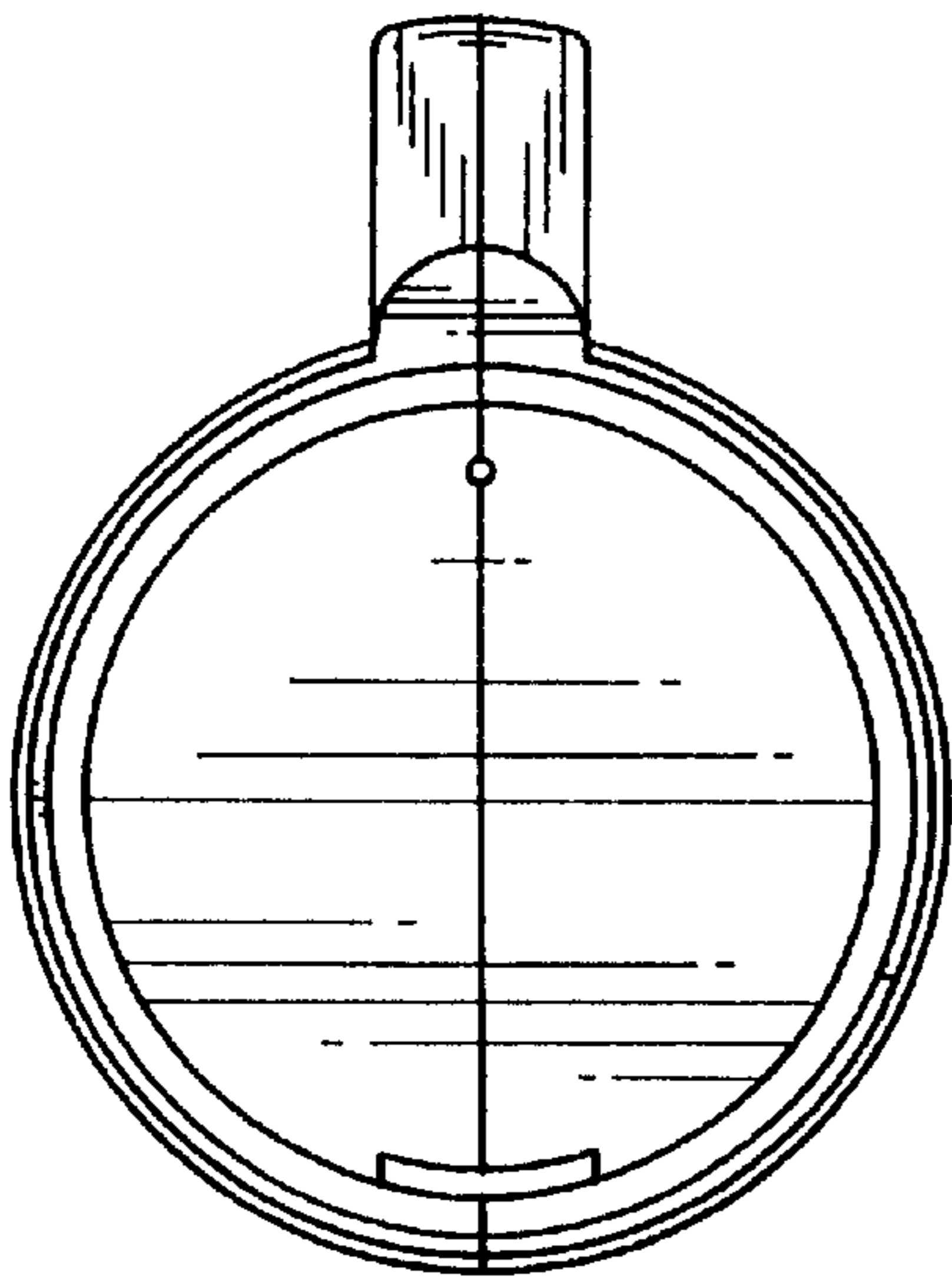

FIG. 2

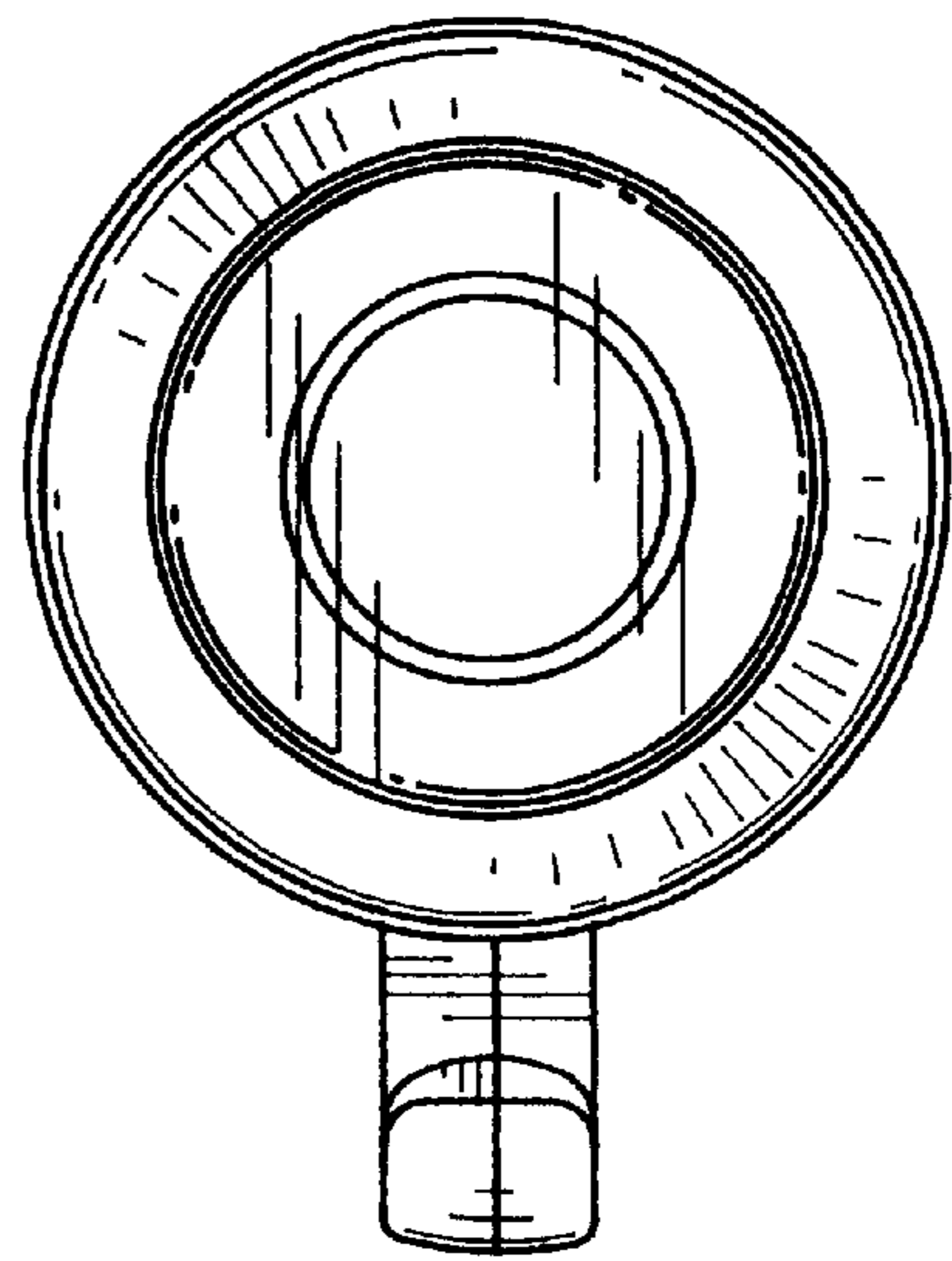

FIG. 3

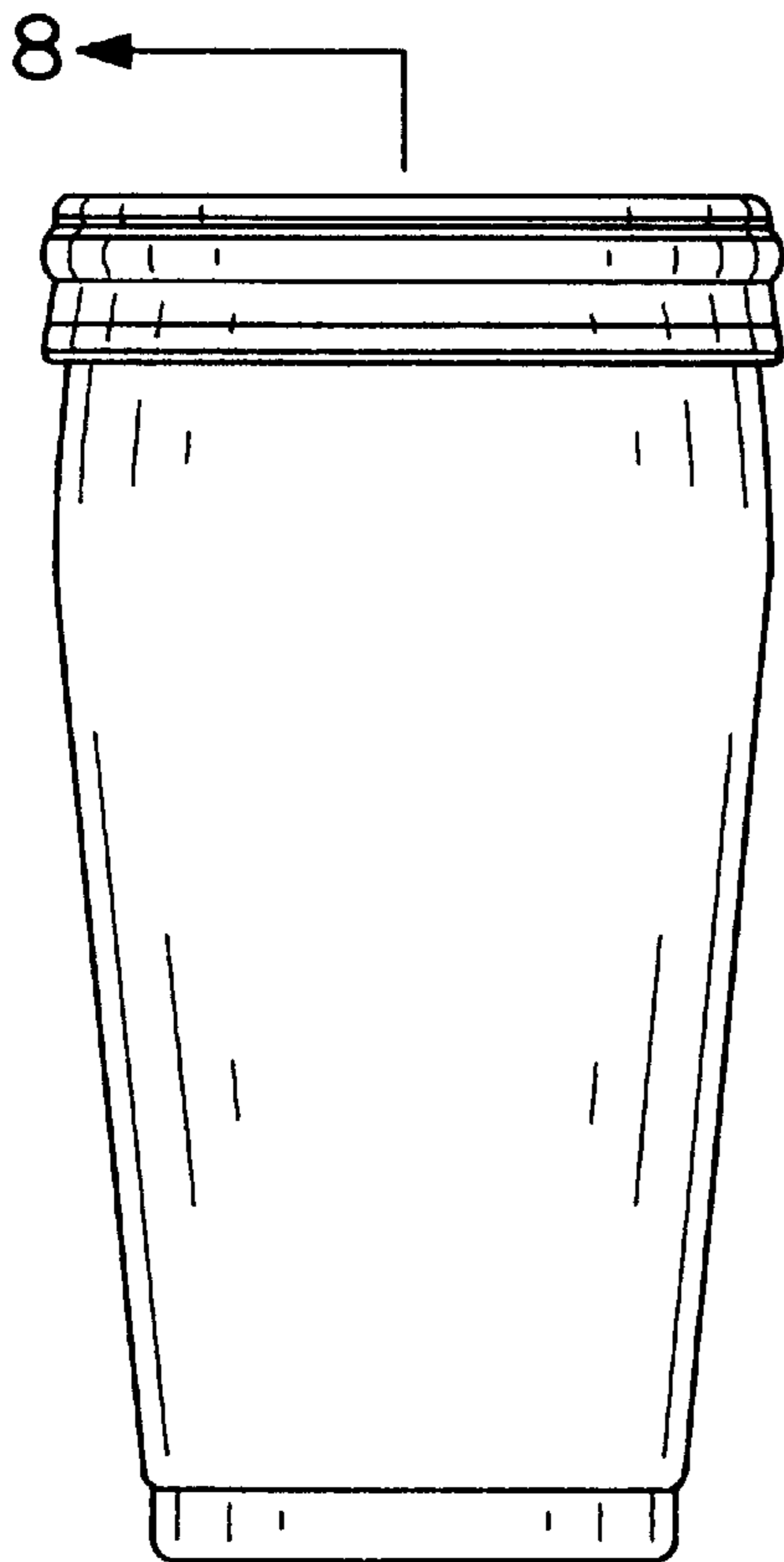

FIG. 4

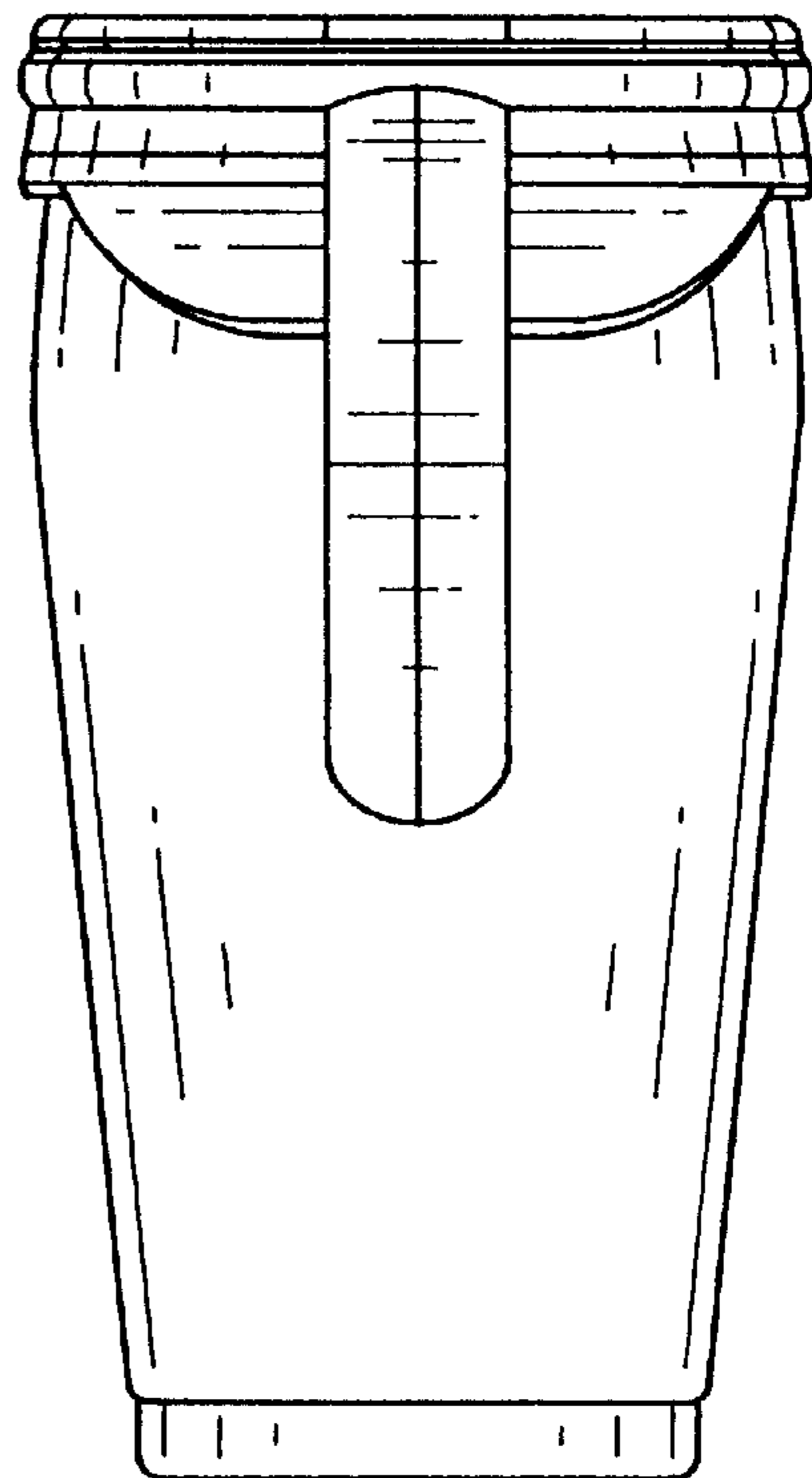

FIG. 5

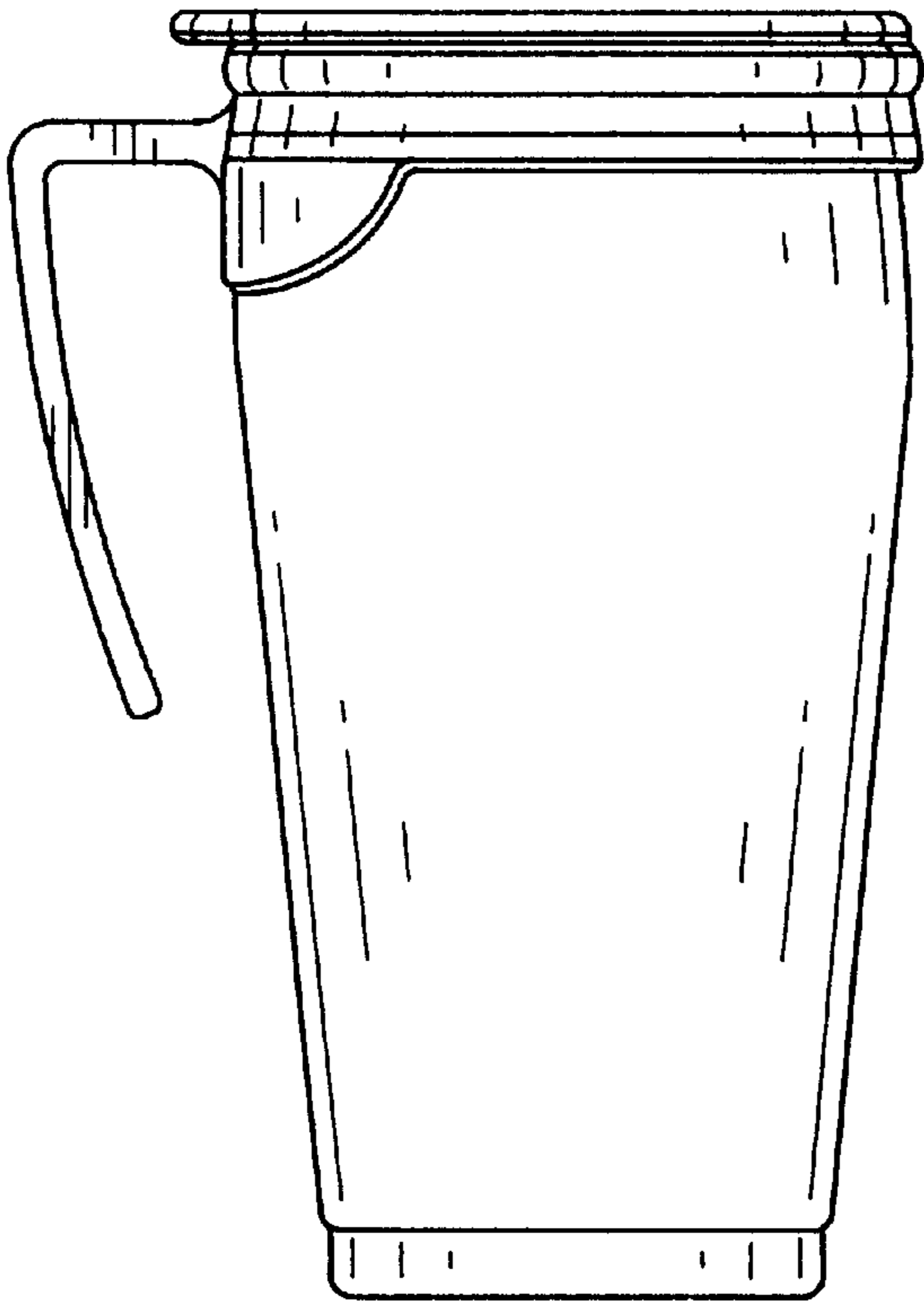

FIG. 6

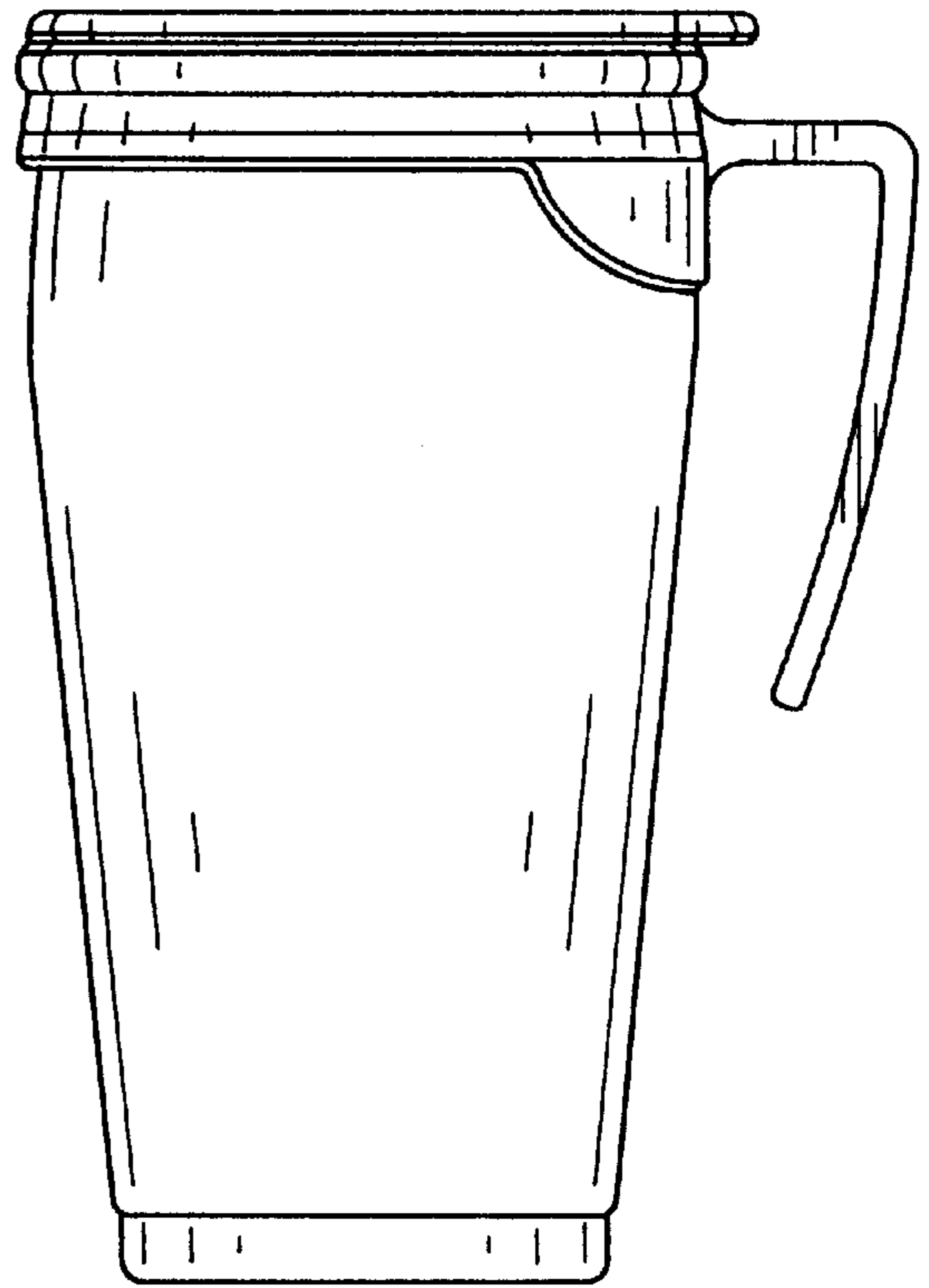

FIG. 7

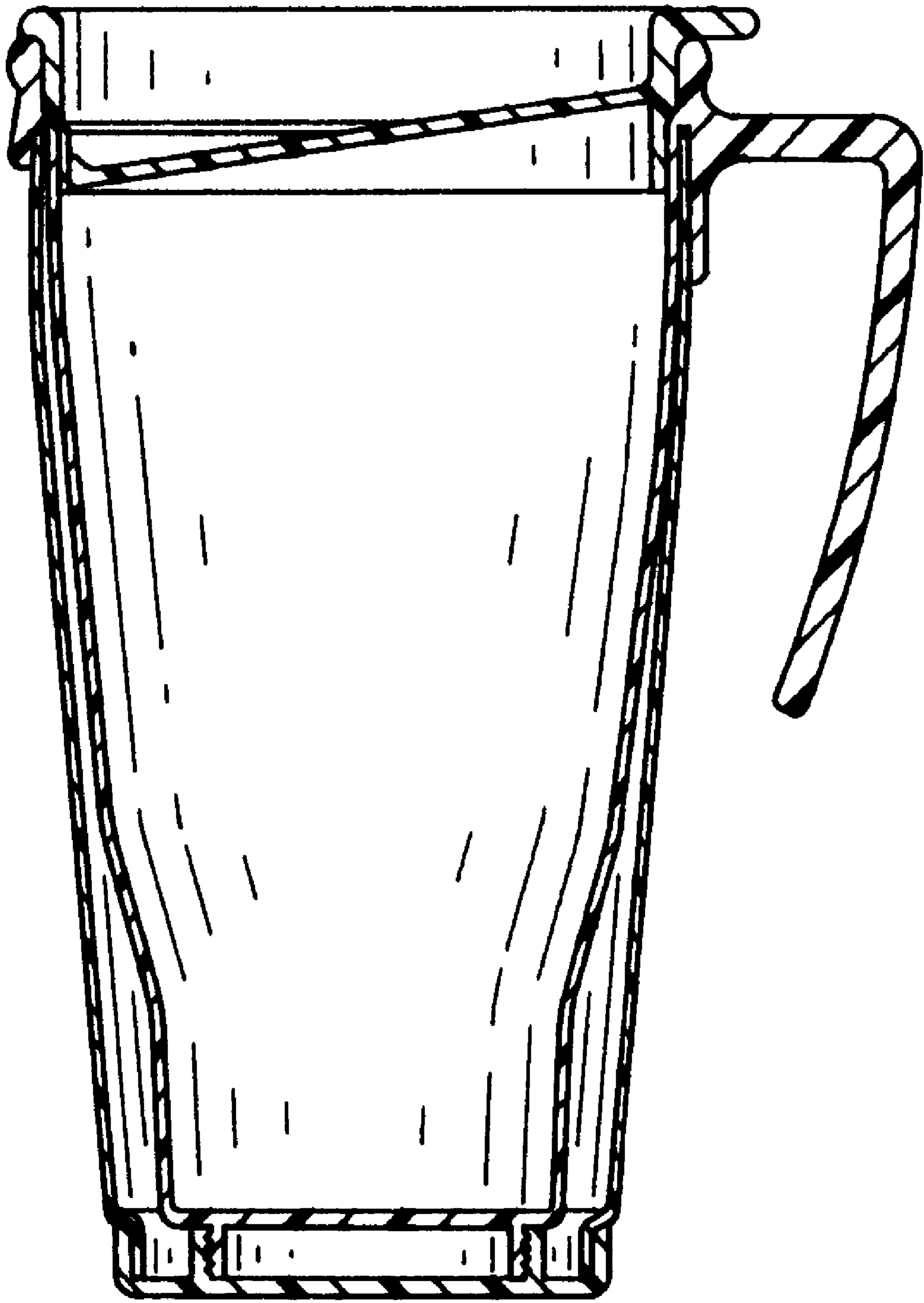

FIG. 8

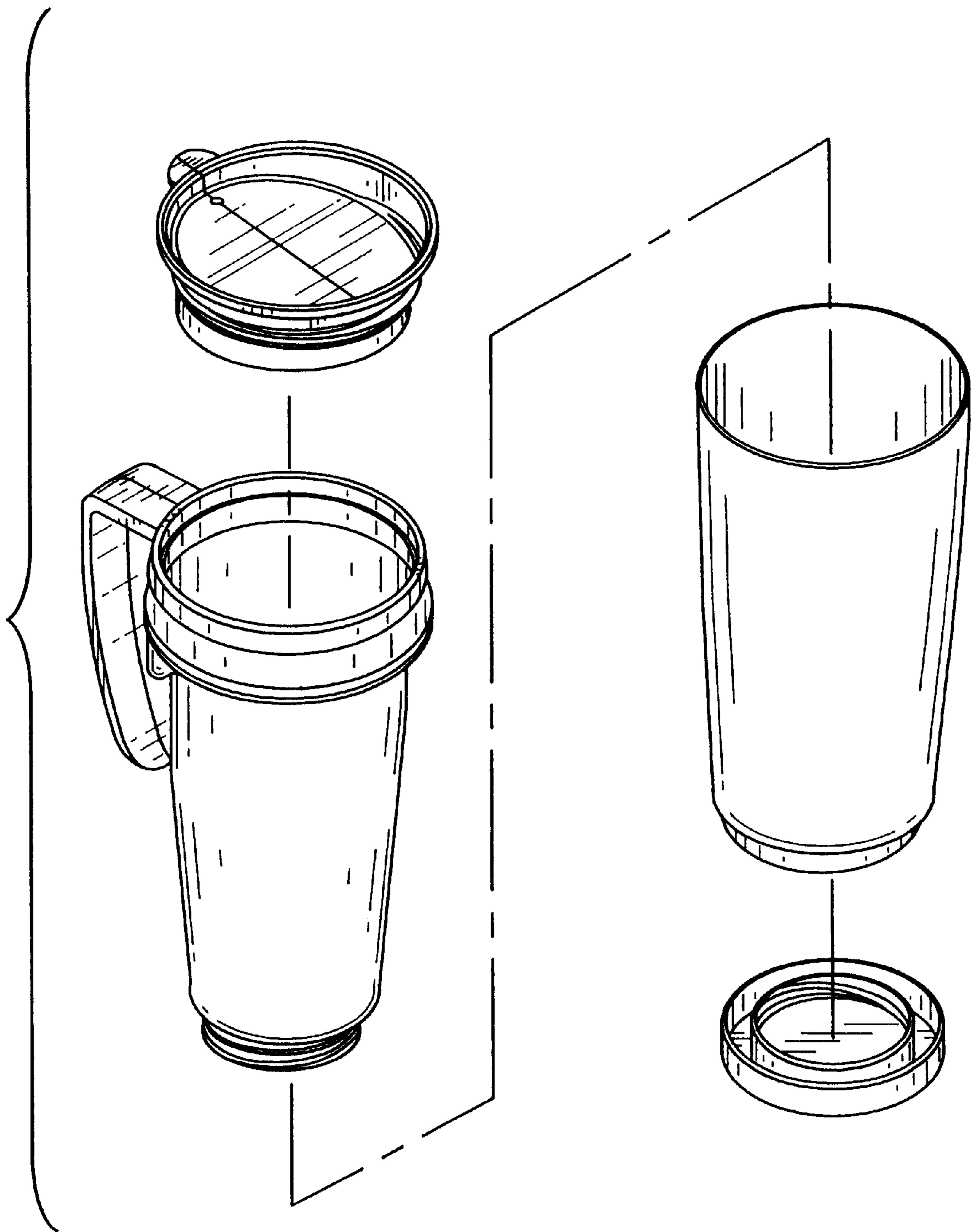

FIG. 9