



US00D419935S

# United States Patent [19] Ryder

[11] **Patent Number: Des. 419,935**

[45] **Date of Patent: \*\* Feb. 1, 2000**

[54] **ARTICULATED SUPPORT FOR VEHICLE REAR VIEW MIRROR**

[75] Inventor: **Barrie James Ryder**, York, United Kingdom

[73] Assignee: **Britax PMG Limited**, North Humberside, United Kingdom

[\*\*] Term: **14 Years**

[21] Appl. No.: **29/099,663**

[22] Filed: **Jan. 26, 1999**

[30] **Foreign Application Priority Data**

Jul. 29, 1998 [GB] United Kingdom ..... 2076410

[51] **LOC (7) Cl.** ..... **12-16**

[52] **U.S. Cl.** ..... **D12/187**

[58] **Field of Search** ..... D12/187; 359/514, 359/871, 872, 881, 844, 864, 866; 248/486

[56] **References Cited**

**U.S. PATENT DOCUMENTS**

D. 268,576 4/1983 Sharp ..... D12/187

D. 285,549 9/1986 Haack ..... D12/187  
D. 300,737 4/1989 Charet et al. .... D12/187  
D. 302,415 7/1989 Kovensky ..... D12/187  
D. 400,482 11/1998 Moir ..... D12/187

*Primary Examiner*—Ralf Seifert  
*Attorney, Agent, or Firm*—Jones, Day, Reavis & Pogue

[57] **CLAIM**

The ornamental design for an articulated support for vehicle rear view mirror, as shown and described.

**DESCRIPTION**

FIG. 1 is a front perspective view of an articulated support for a vehicle rear view mirror showing my new design; FIG. 2 is a rear perspective view thereof; FIG. 3 is another front perspective view thereof; and, FIG. 4 is a top plan view thereof.

The broken line illustration in the drawings is for illustrative purposes only and is not part of the design sought to be protected.

**1 Claim, 2 Drawing Sheets**

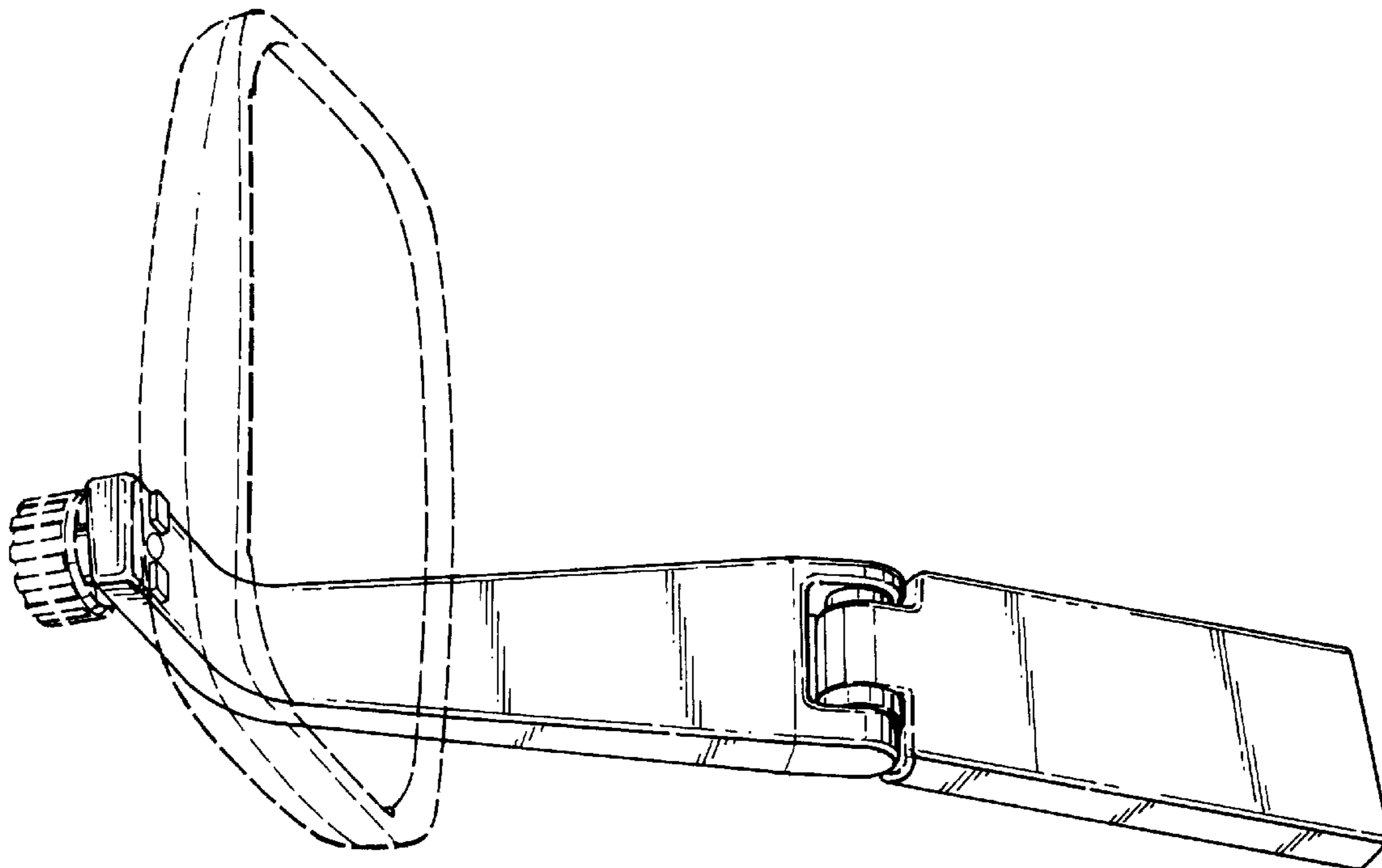

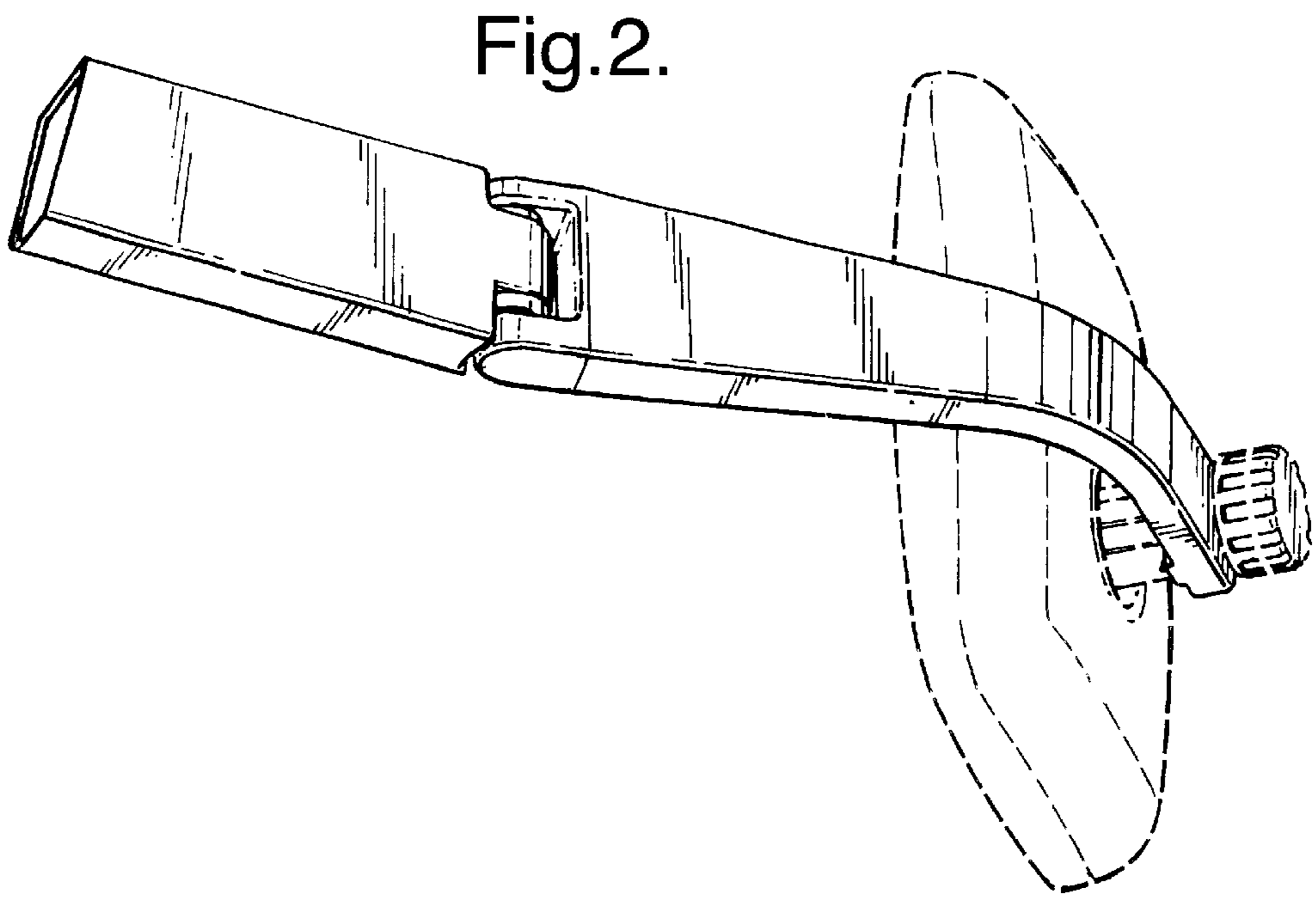
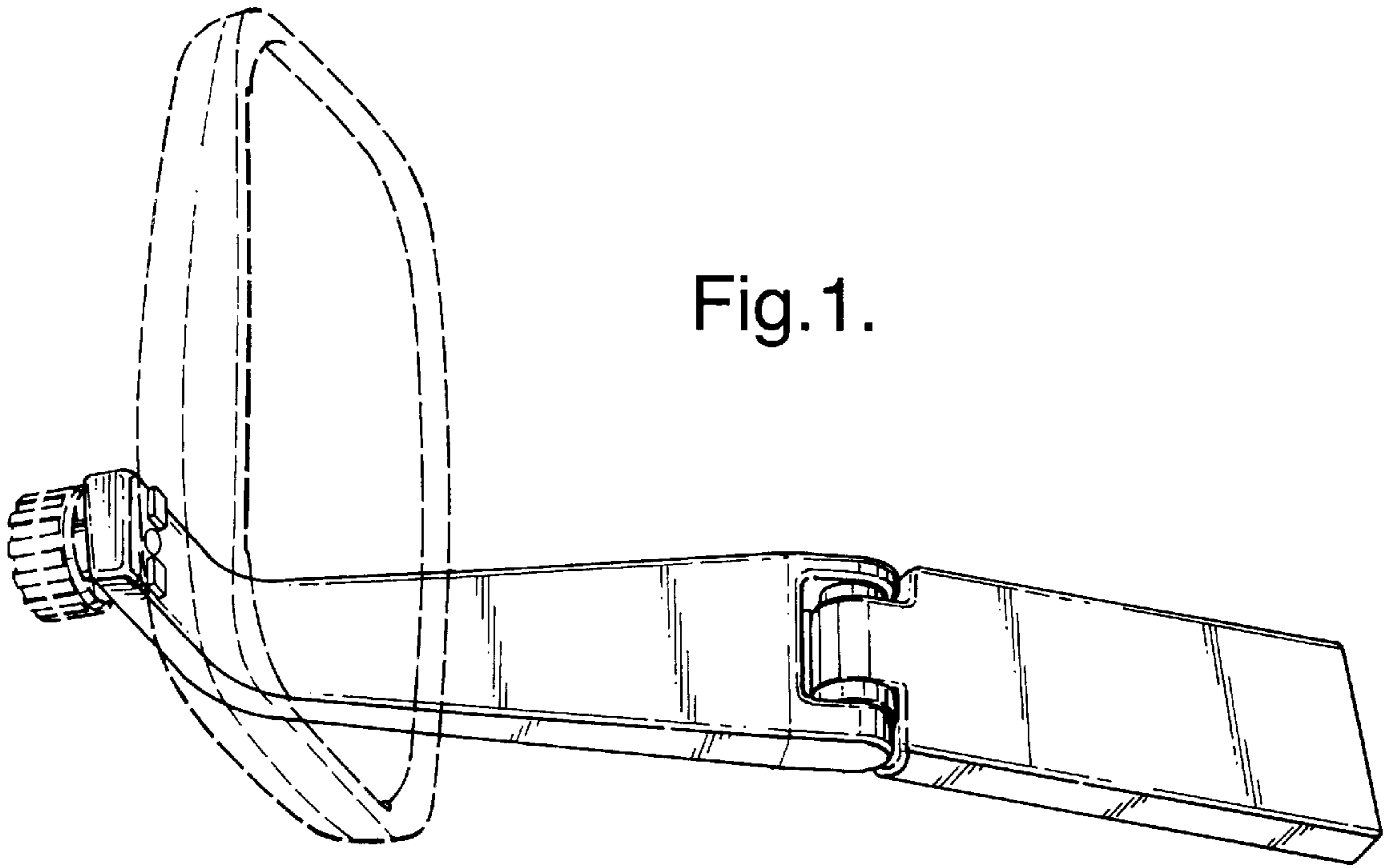

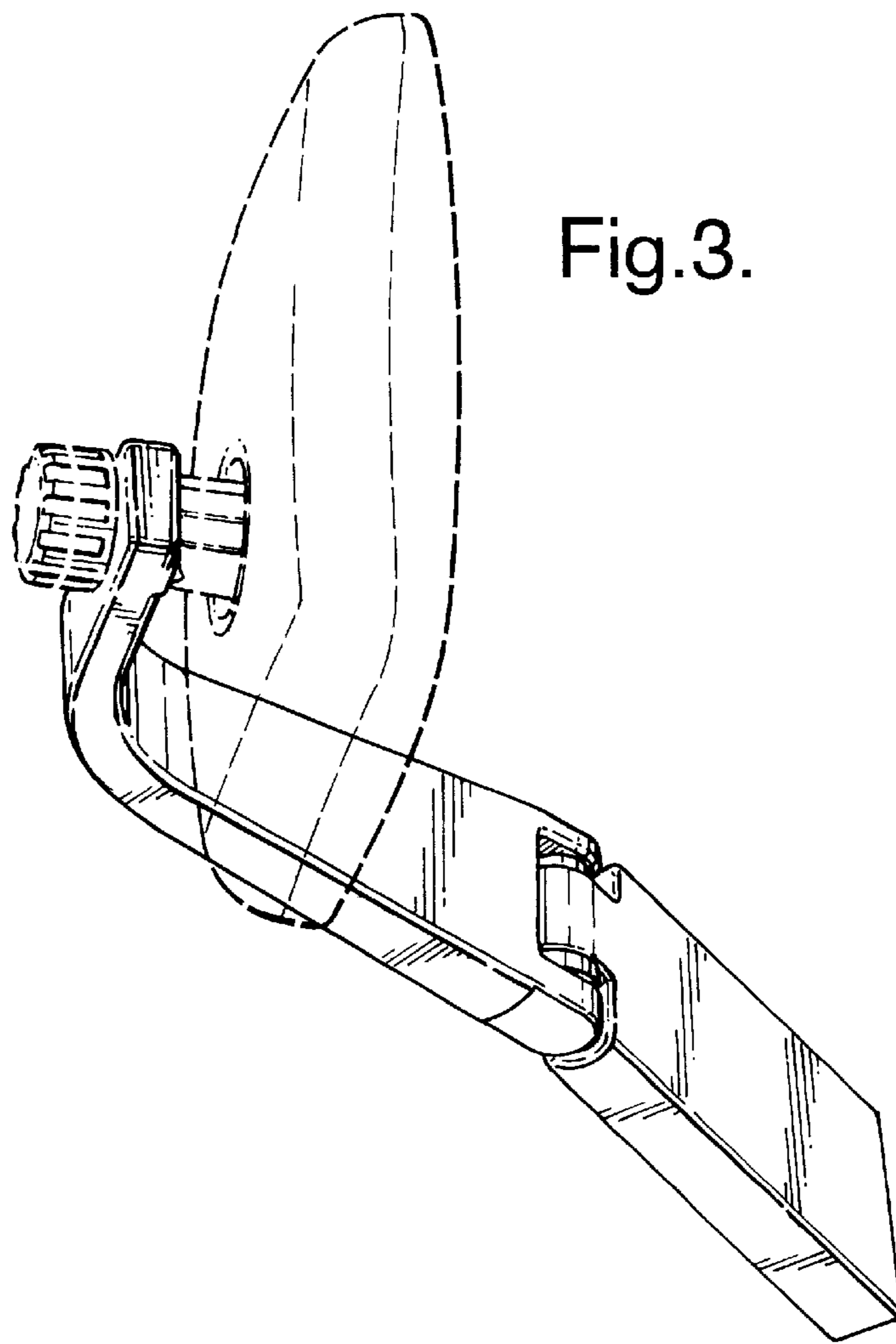

Fig.3.

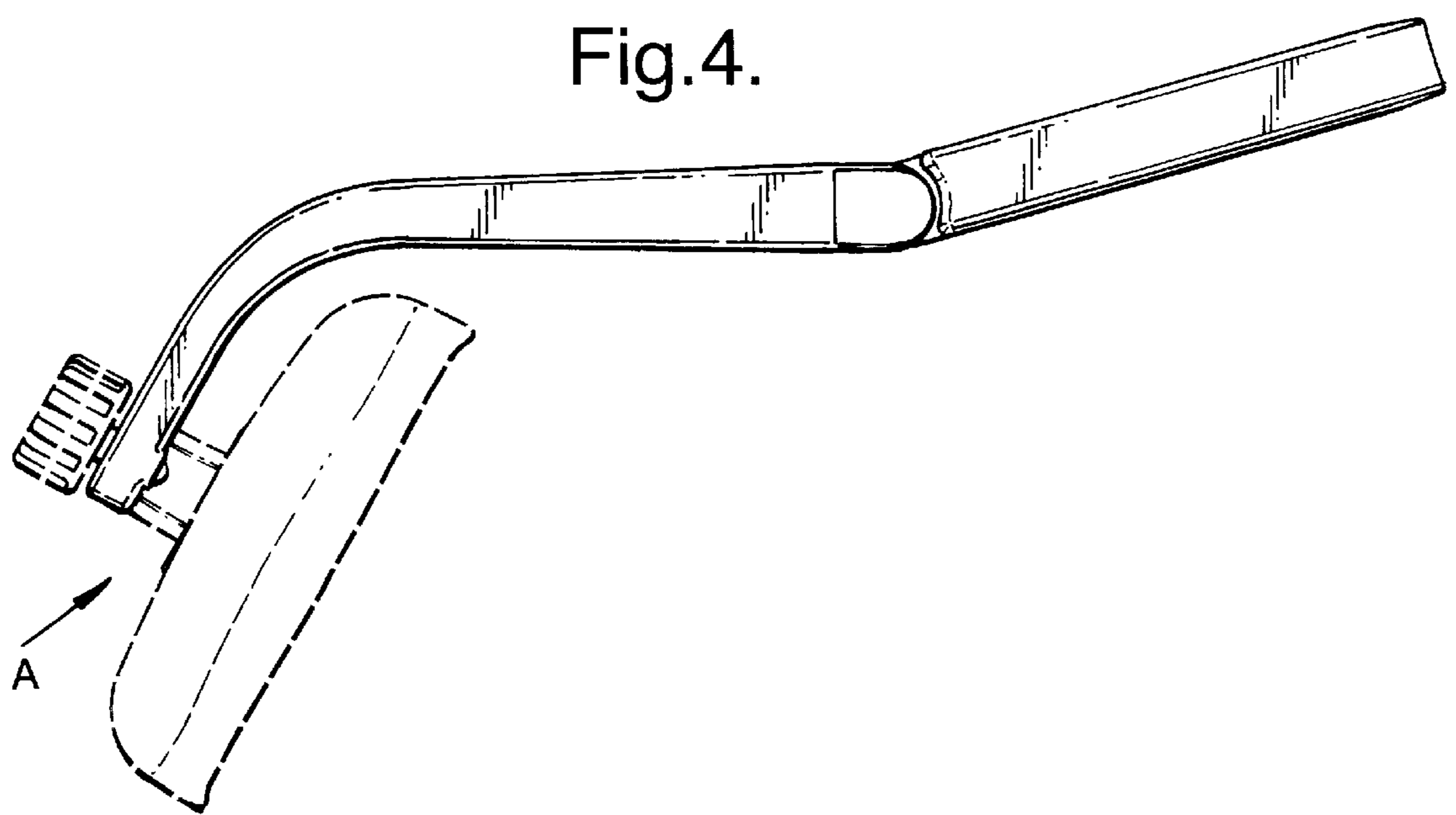

Fig.4.

A