



US00D419587S

United States Patent [19] Okamura

[11] **Patent Number: Des. 419,587**

[45] **Date of Patent: ** Jan. 25, 2000**

[54] **ELECTRIC CELLO**

[75] Inventor: **Sunao Okamura**, Hamamatsu, Japan

[73] Assignee: **Yamaha Corporation**, Japan

[**] Term: **14 Years**

[21] Appl. No.: **29/096,964**

[22] Filed: **Nov. 24, 1998**

[30] **Foreign Application Priority Data**

Jul. 13, 1998 [JP] Japan 10-19197

[51] **LOC (7) Cl.** **17-03**

[52] **U.S. Cl.** **D17/14; D17/17; 84/743**

[58] **Field of Search** D17/14, 17, 18,
D17/19, 20; 84/267, 291, 274, 275, 276,
277, 723, 726, 727, 728, 731, 735, 743

[56] **References Cited**

U.S. PATENT DOCUMENTS

D. 360,219 7/1995 McCann D17/14

D. 395,912 7/1998 Schaub D17/14
D. 403,013 12/1998 Honda D17/17
4,632,002 12/1986 Clevinger 84/731

OTHER PUBLICATIONS

The NAMM Publication "Upbeat" p. 3 (Yamaha's electric violin) Jul. 1998.

Primary Examiner—Adir Aronovich
Attorney, Agent, or Firm—Ostrolenk, Faber, Gerb & Soffen, LLP

[57] **CLAIM**

The ornamental design for an electric cello, as shown.

DESCRIPTION

FIG. 1 is a front view of electric cello
FIG. 2 is a left side view thereof;
FIG. 3 is a right side view thereof;
FIG. 4 is a top view thereof;
FIG. 5 is a bottom view thereof; and,
FIG. 6 is a rear view thereof.

1 Claim, 4 Drawing Sheets

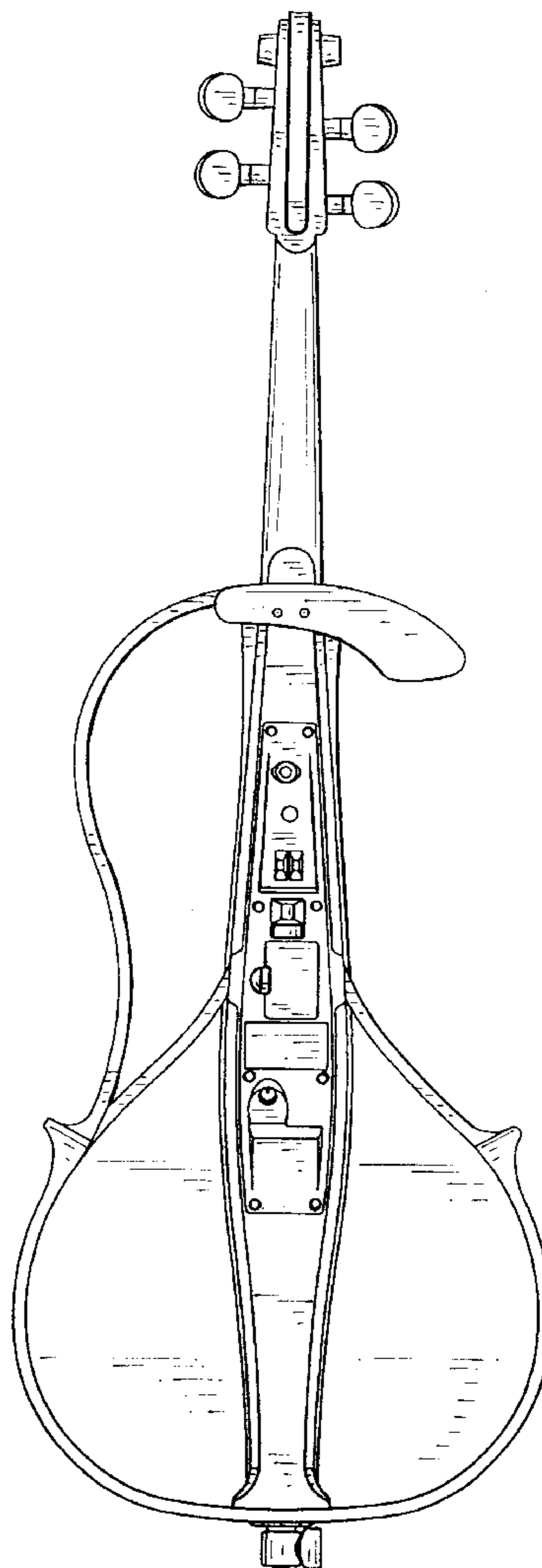
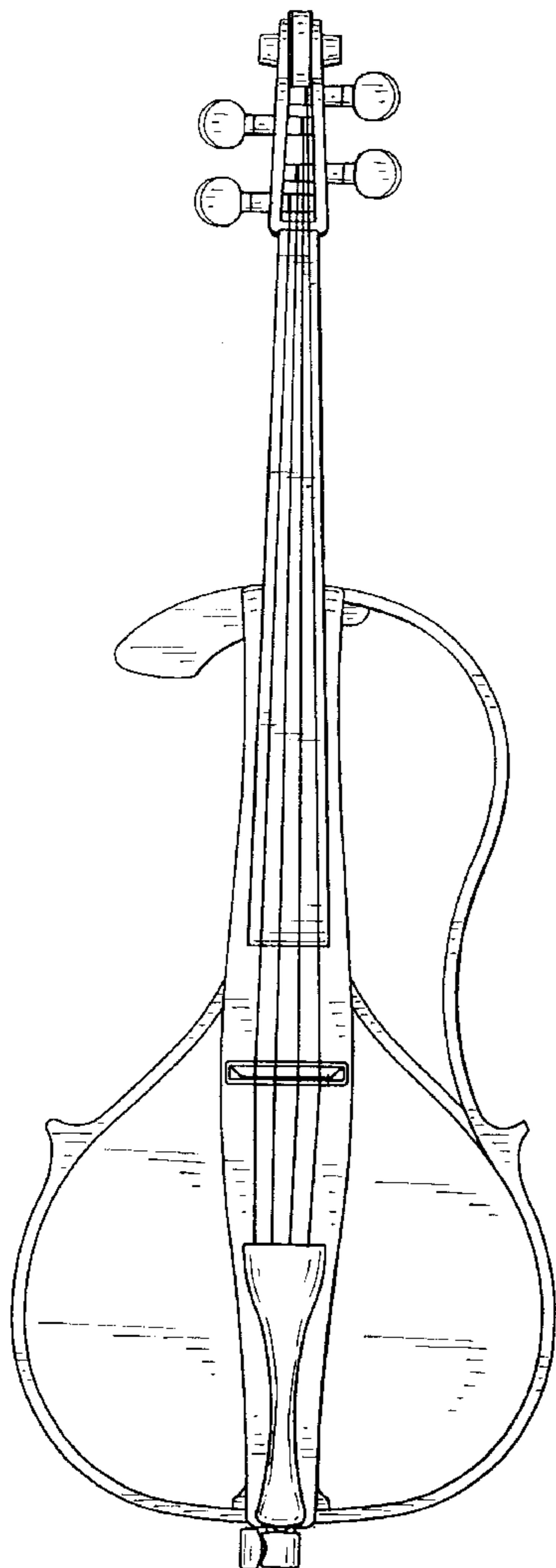

Fig. 1

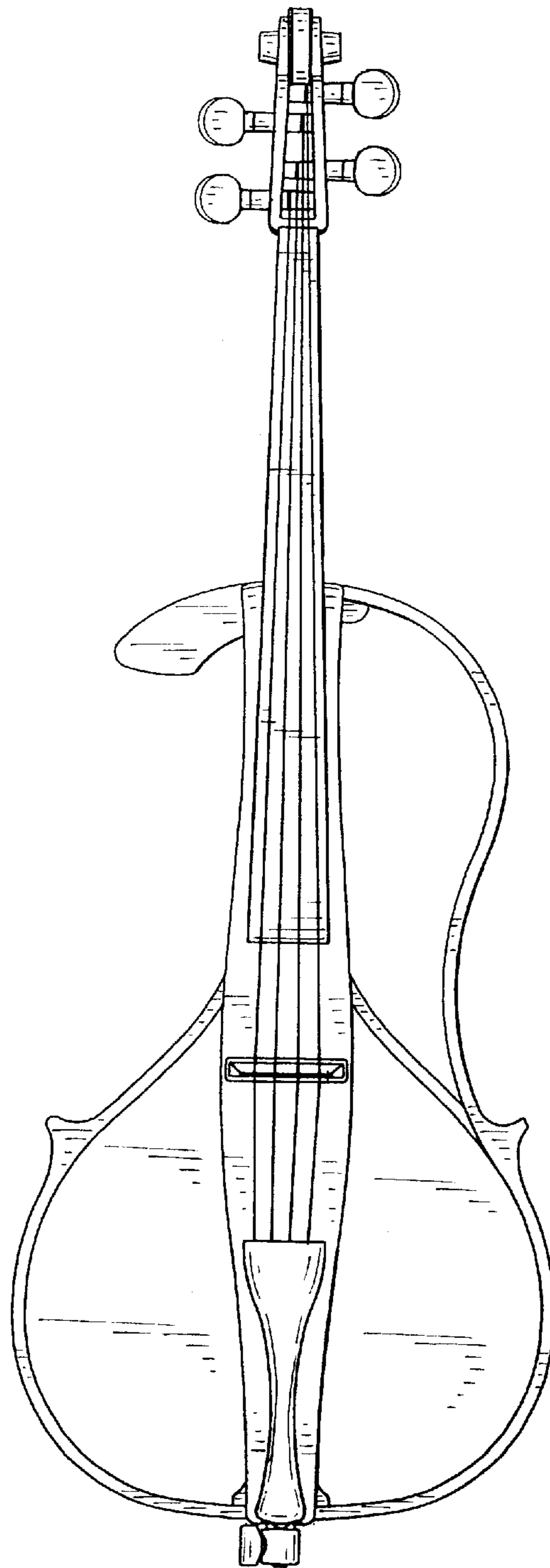

Fig.2

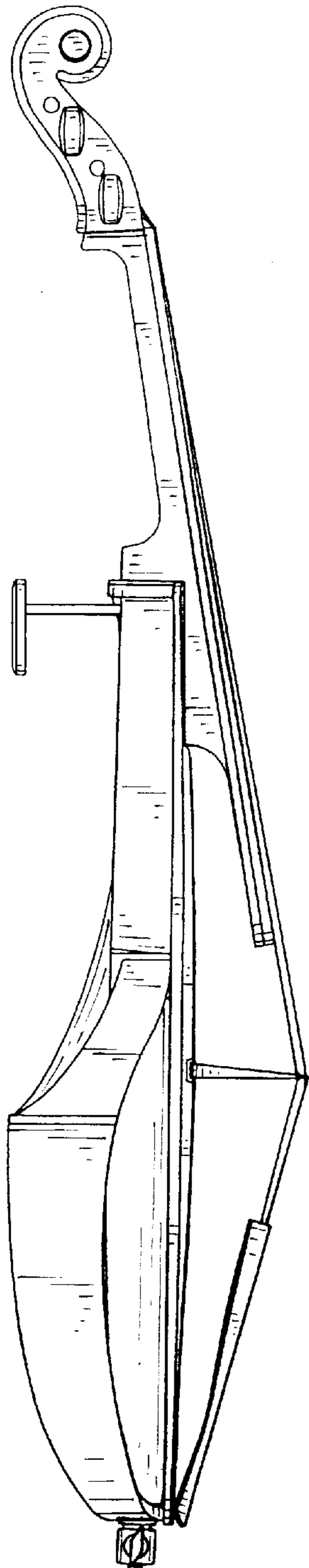

Fig.3

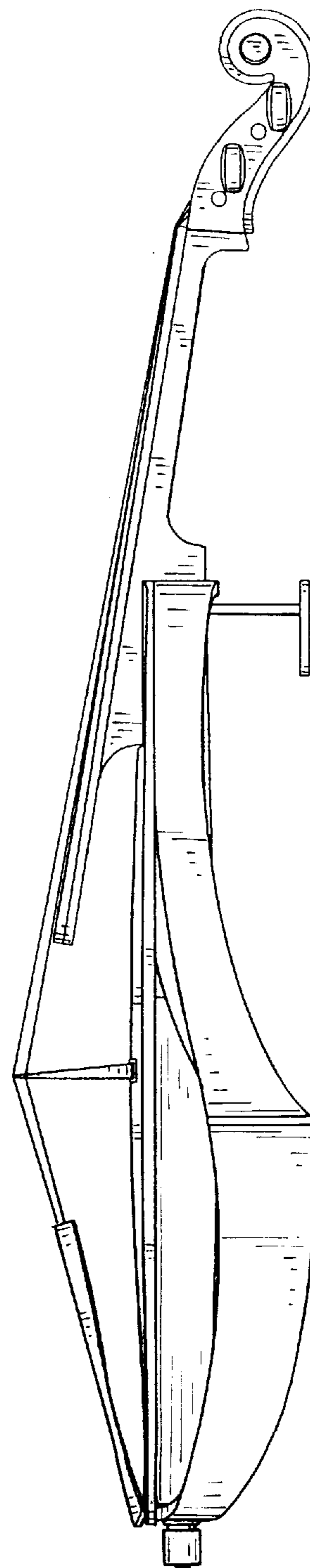

Fig. 4

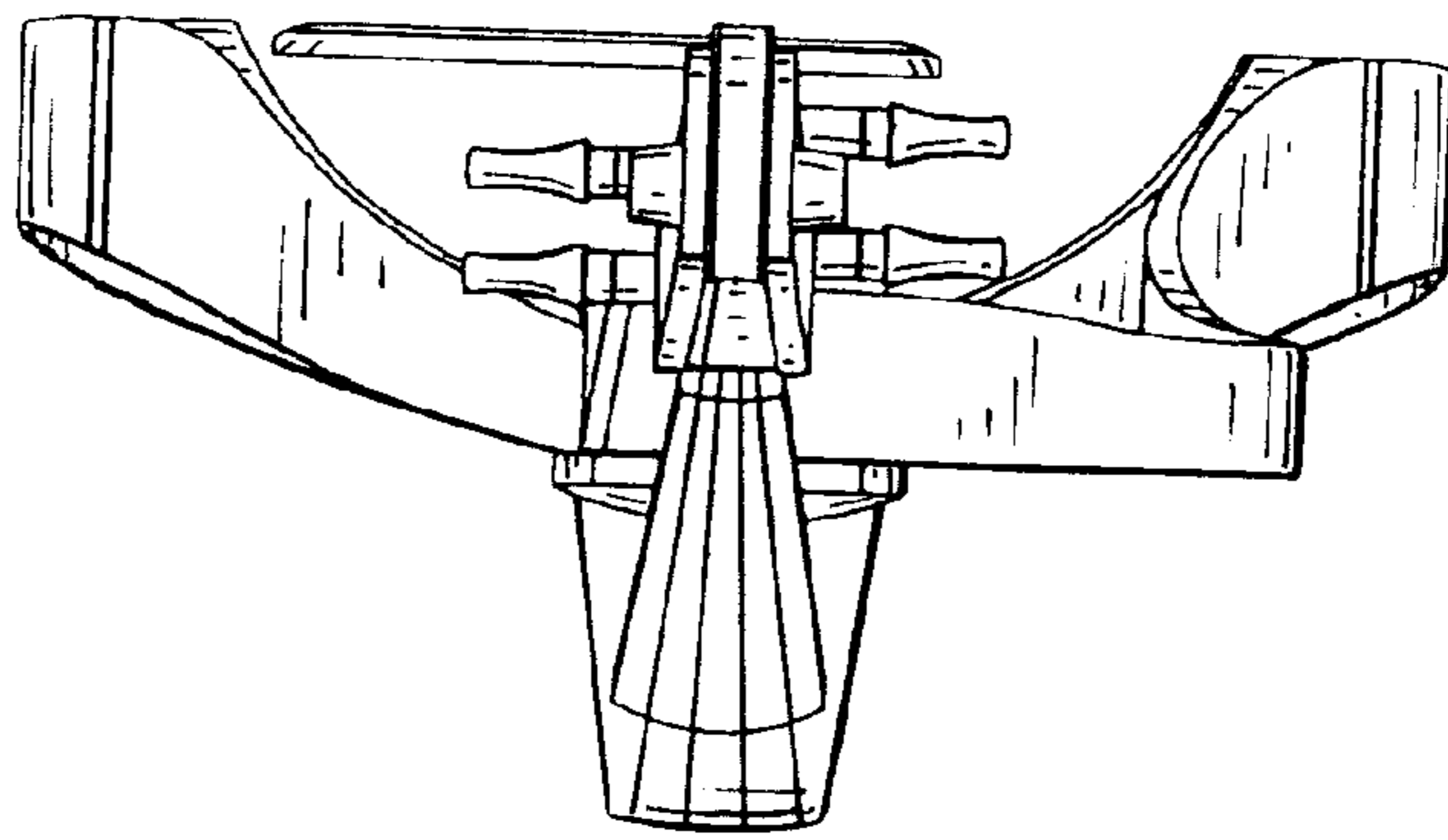

Fig. 5

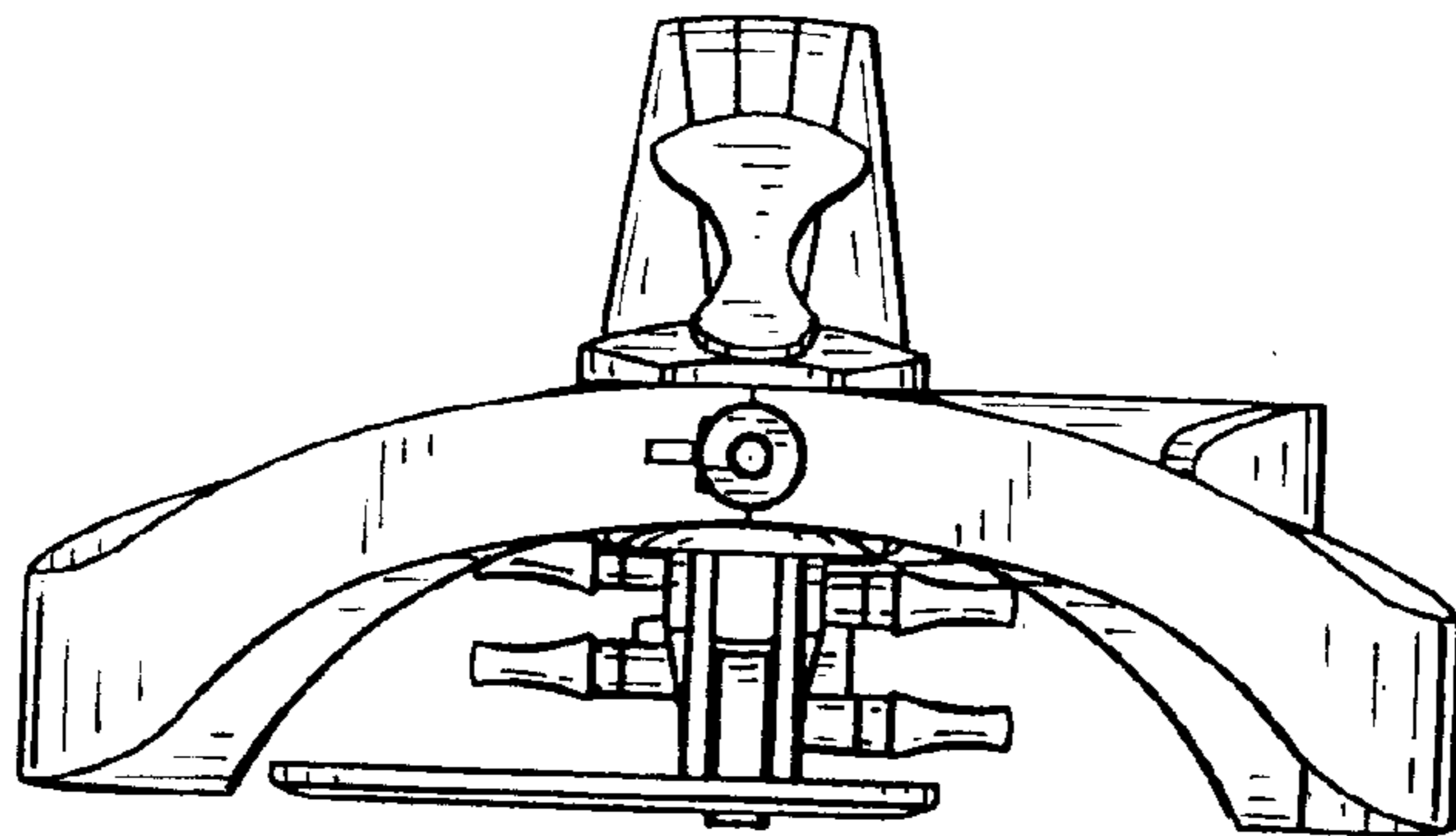

Fig. 6

