



US00D419523S

# United States Patent [19] Rothenbaum

[11] Patent Number: **Des. 419,523**

[45] Date of Patent: **\*\* Jan. 25, 2000**

[54] UNIVERSAL SERIAL BUSS

[76] Inventor: **Perry Rothenbaum**, 42W 447  
Audubon Ct., St. Charles, Ill. 60175

[\*\*] Term: **14 Years**

[21] Appl. No.: **29/097,048**

[22] Filed: **Nov. 27, 1998**

[51] LOC (7) Cl. .... **13-03**

[52] U.S. Cl. .... **D13/147**

[58] Field of Search ..... D13/133, 146,  
D13/147; 439/638, 626, 656, 540.1, 490,  
488

### [56] References Cited

#### U.S. PATENT DOCUMENTS

D. 316,079	4/1991	Sulikowski	.....	D13/147
4,764,122	8/1988	Sorel et al.	.....	439/66
5,162,616	11/1992	Swaffield et al.	.....	174/99 B
5,872,711	2/1999	Janko	.....	361/611 X

#### OTHER PUBLICATIONS

Product Illustration from Internet site of ParaCom Technologies, Inc. Wichita, KS.  
Product Illustration from Internet site of Belkin Components, Compton, CA.

Product Illustration from Internet site of CATC, Santa Clara, CA.

Product Illustration from Internet of Inside Out Networks, Austin, TX.

*Primary Examiner*—Joel Sincavage  
*Attorney, Agent, or Firm*—Philip H. Kier

### [57] CLAIM

The ornamental design for a universal serial buss, as shown and described.

### DESCRIPTION

FIG. 1 is a perspective view taken from the front, bottom, and right side of universal serial buss showing my new design;

FIG. 2 is a perspective view taken from the front, top, and right side thereof;

FIG. 3 is a front elevational view thereof;

FIG. 4 is a back elevational view thereof;

FIG. 5 is a right side elevational view thereof, the left side being a mirror image;

FIG. 6 is a bottom plan view thereof; and,

FIG. 7 is a top plan view thereof.

The broken line showing in FIGS. 1, 2 and 3 are included to illustrate environmental features only and form no part of the claimed design.

**1 Claim, 4 Drawing Sheets**

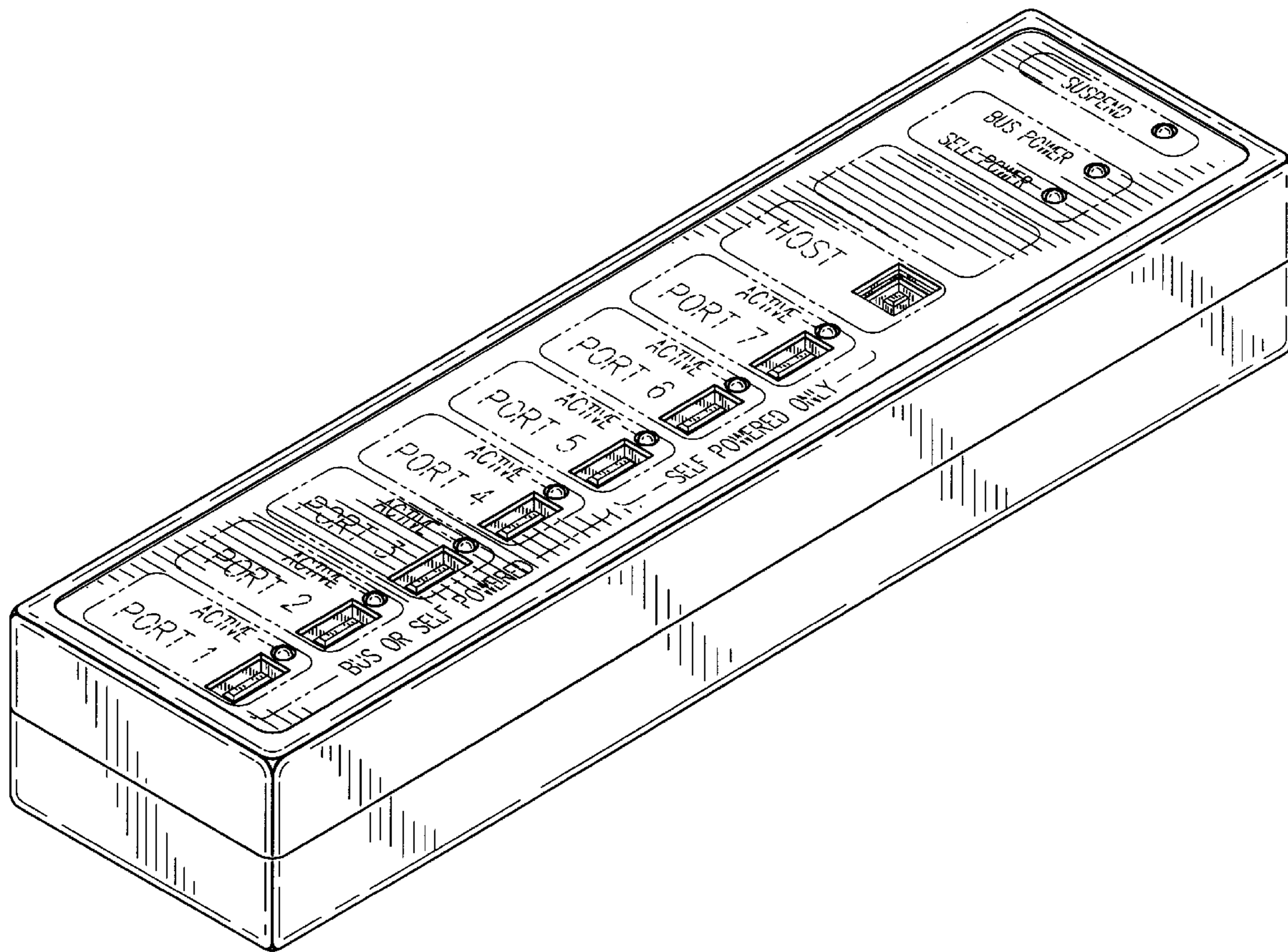

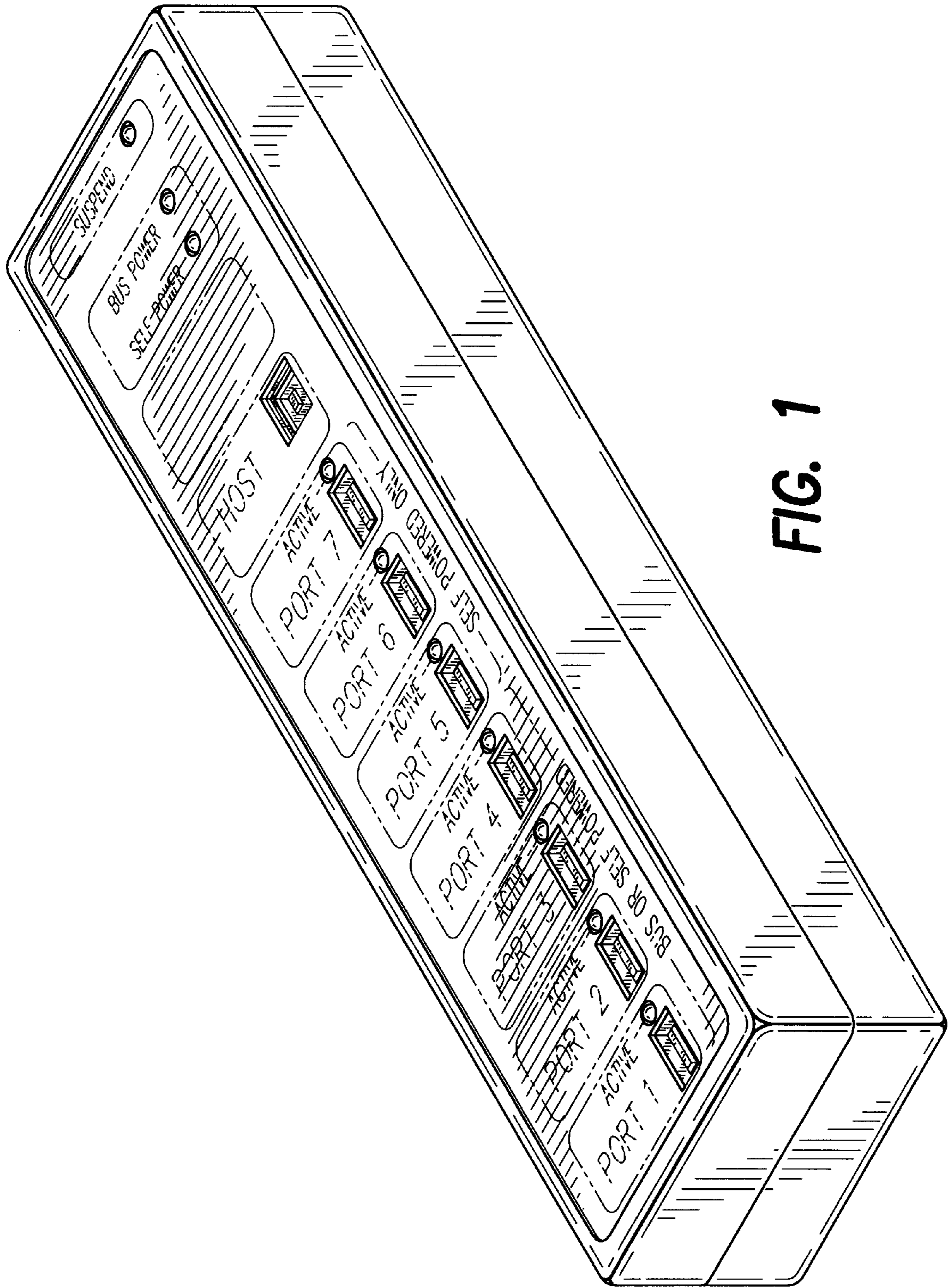

FIG. 1



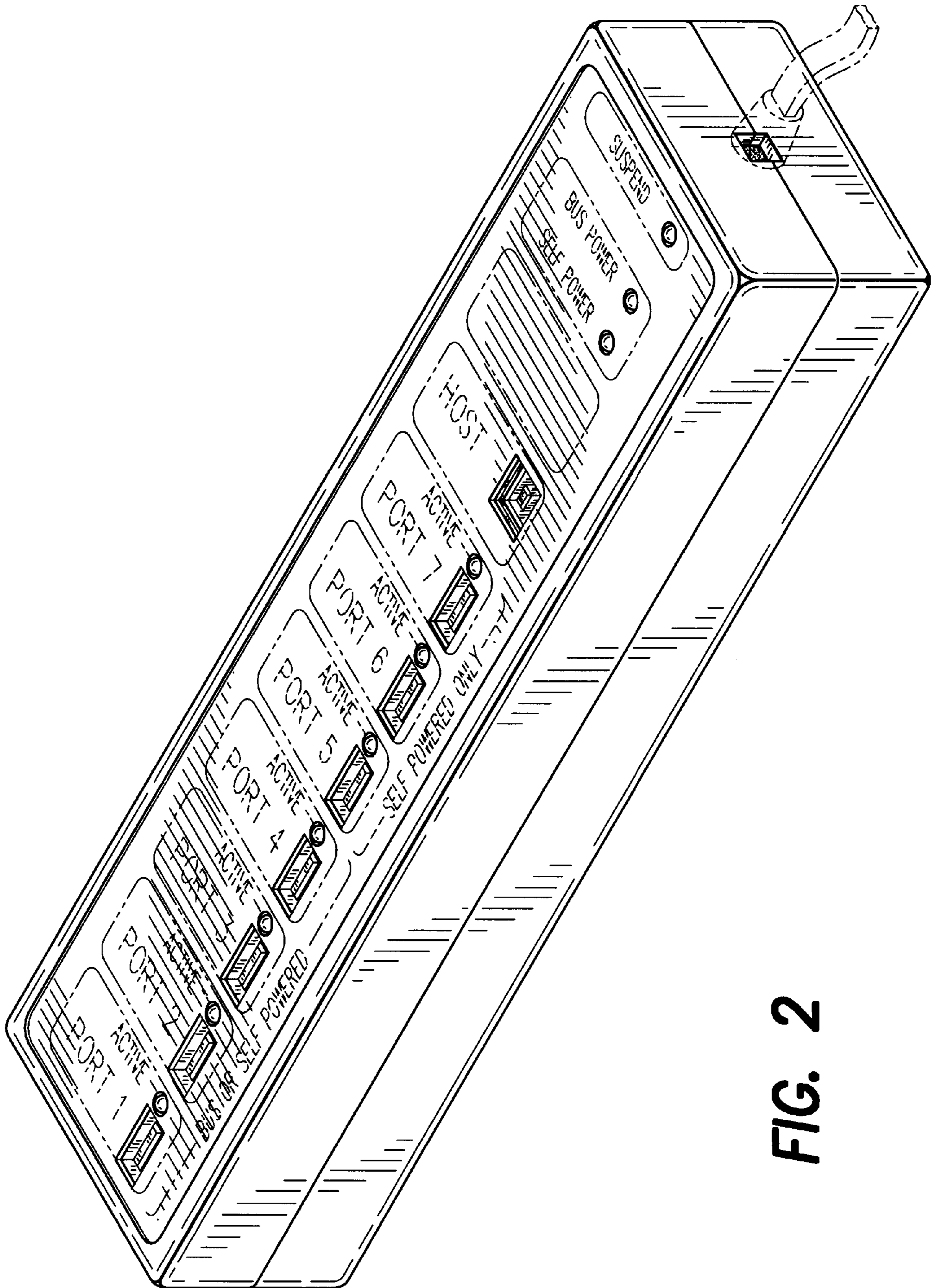

FIG. 2

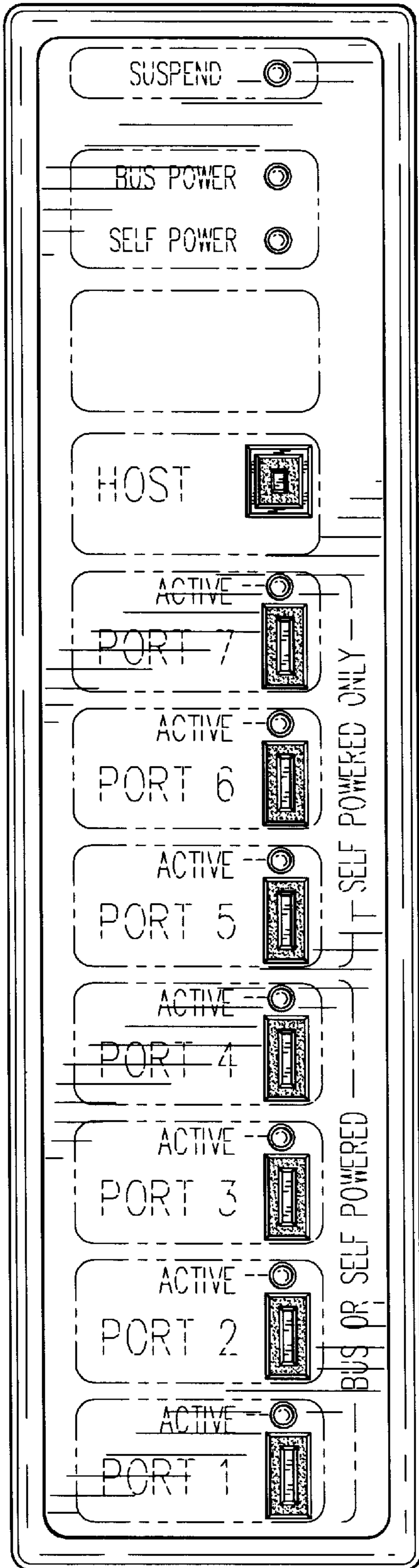

FIG. 3

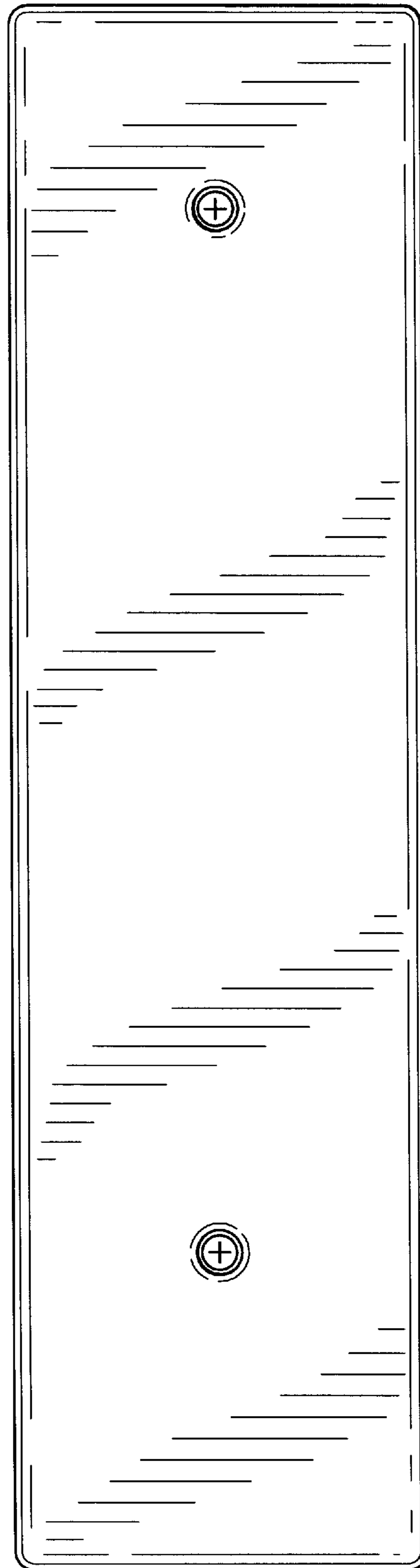
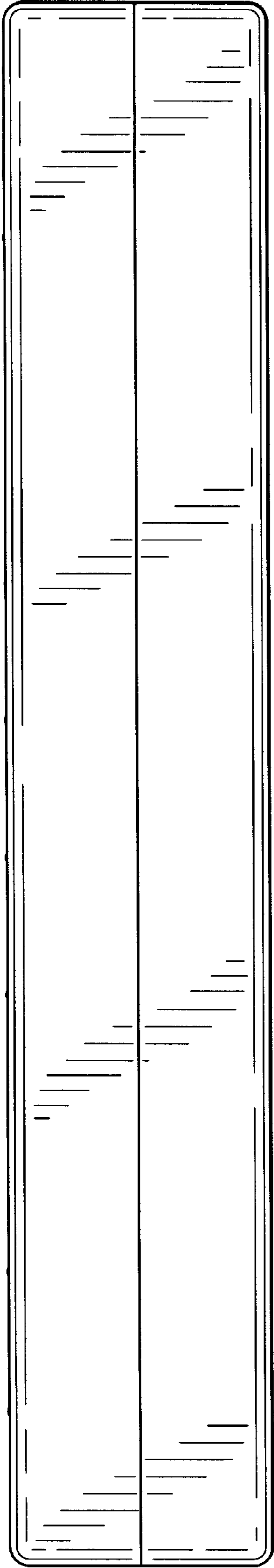
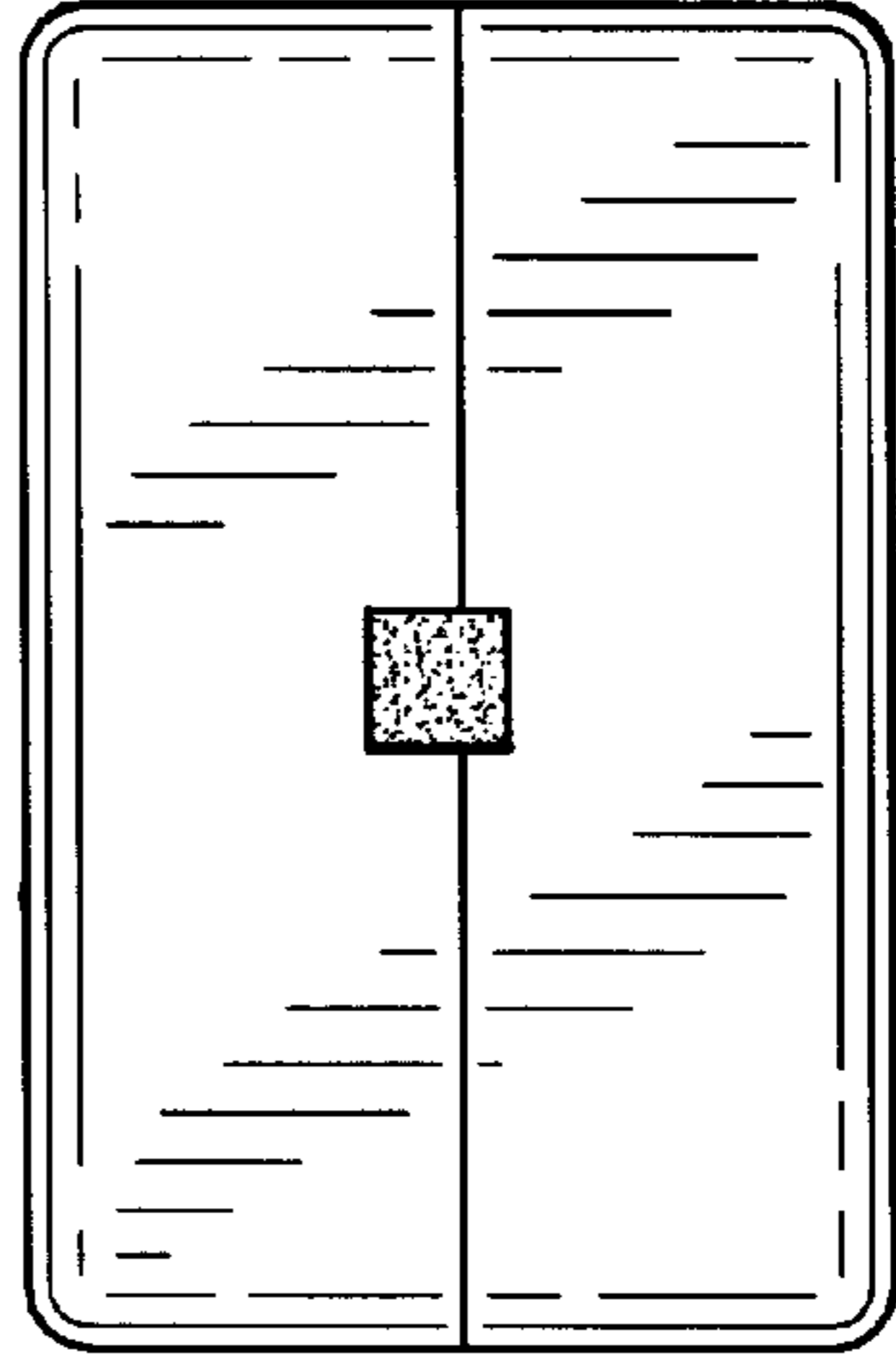

FIG. 4



**FIG. 5**



**FIG. 7**

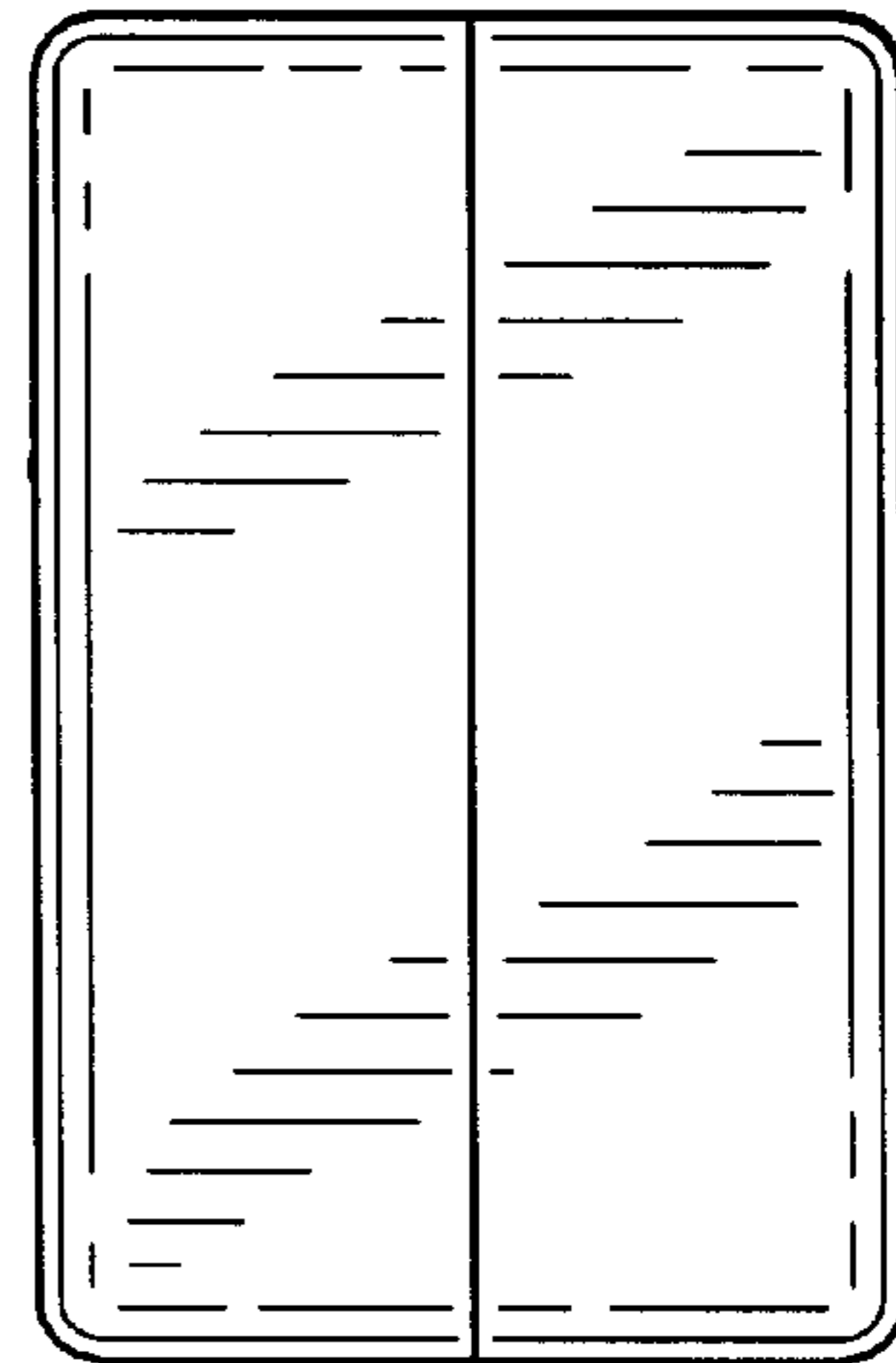

**FIG. 6**

UNITED STATES PATENT AND TRADEMARK OFFICE  
CERTIFICATE OF CORRECTION

PATENT NO : Des. 419,523

DATED : January 25, 2000

INVENTOR(S): Perry Rothenbaum

It is certified that error appears in the above-identified patent and that said Letters Patent is hereby corrected as shown below: Title page, item [54] and col. 1,

In the title, "BUSS" should read --BUS--; in the claim, "buss" should read --bus--; and in the description of FIG. 1, "buss" should read --bus--.

Signed and Sealed this  
Fifth Day of December, 2000

*Attest:*

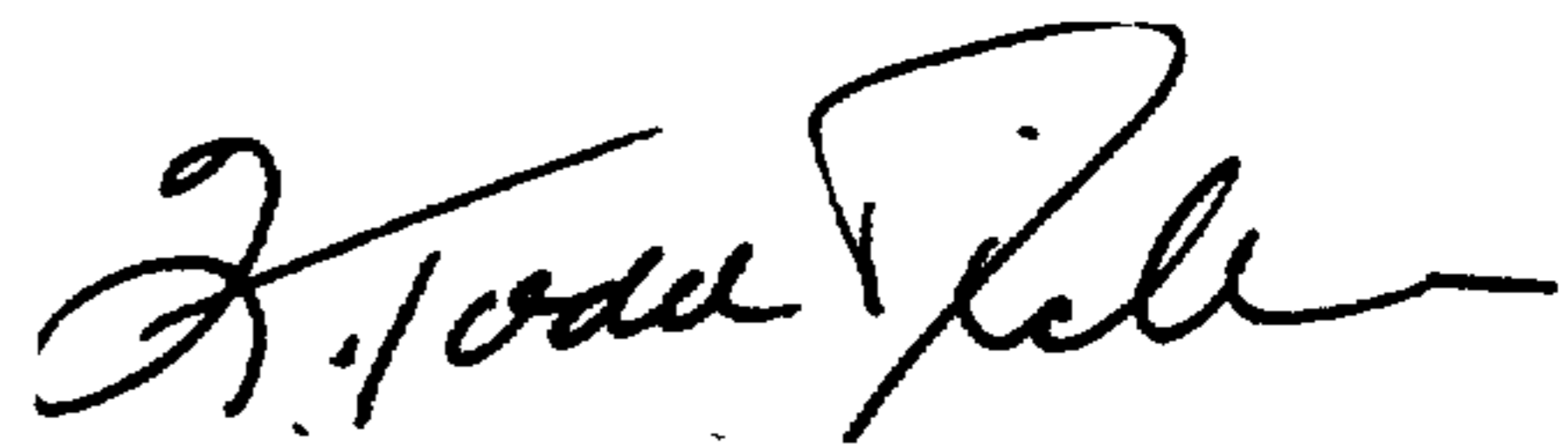

Q. TODD DICKINSON

*Attesting Officer*

*Director of Patents and Trademarks*