



US00D419491S

United States Patent [19]
Allen

[11] **Patent Number: Des. 419,491**
[45] **Date of Patent: ** Jan. 25, 2000**

[54] **VEHICLE BODY**

Attorney, Agent, or Firm—Mark P. Calcaterra

[75] Inventor: **Mark T. Allen**, Troy, Mich.

[57] **CLAIM**

[73] Assignee: **DaimlerChrysler Corporation**, Auburn Hills, Mich.

The ornamental design for a vehicle body, as shown and described.

[**] Term: **14 Years**

DESCRIPTION

[21] Appl. No.: **29/097,918**

FIG. 1 is a front perspective view of a vehicle body constructed in accordance with the teachings of the present invention.

[22] Filed: **Dec. 17, 1998**

FIG. 2 is a rear perspective view thereof.

[51] **LOC (7) Cl.** **12-08**

[52] **U.S. Cl.** **D12/98**

[58] **Field of Search** D12/98; 296/183

FIG. 3 is a front view thereof; and,

[56] **References Cited**

U.S. PATENT DOCUMENTS

D. 355,149	2/1995	Payne et al.	D12/96
D. 373,979	9/1996	Starr et al.	D12/98
D. 379,439	5/1997	Bradley	D12/98
D. 396,666	8/1998	Allen	D12/98
D. 405,392	2/1999	Allen	D12/98

FIG. 4 is a rear view thereof.

OTHER PUBLICATIONS

Standard Catalog of 4x4's 1945–1993 by Krause Publications, Inc., Copyright 1995, pp. 109–144.

It will be understood that the left and right sides of the vehicle are substantially mirror images. It will be further understood that the broken line showing of wheels and tires throughout the drawings is for illustrative purposes only and forms no part of the subject invention.

Primary Examiner—Melody N. Brown

1 Claim, 3 Drawing Sheets

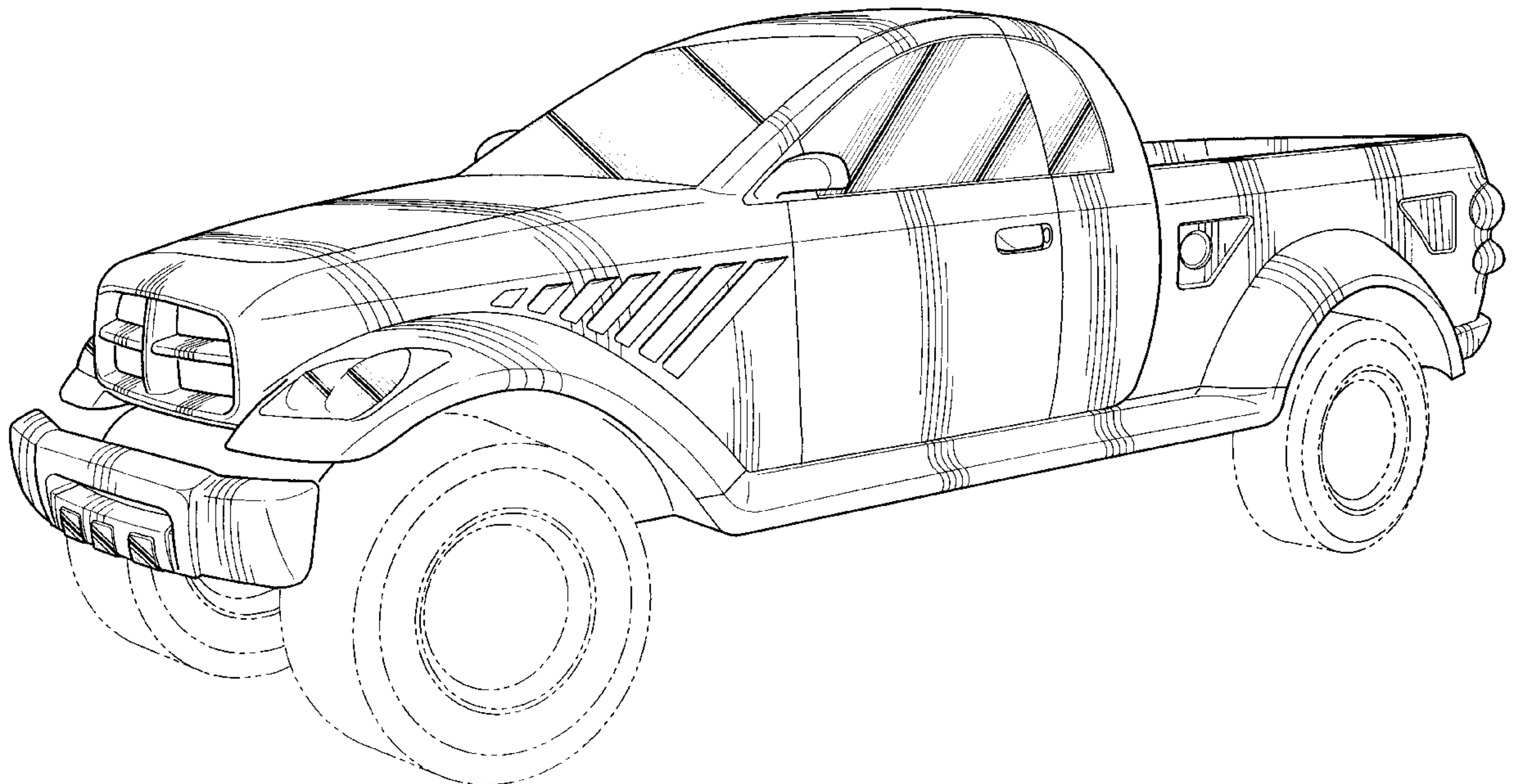

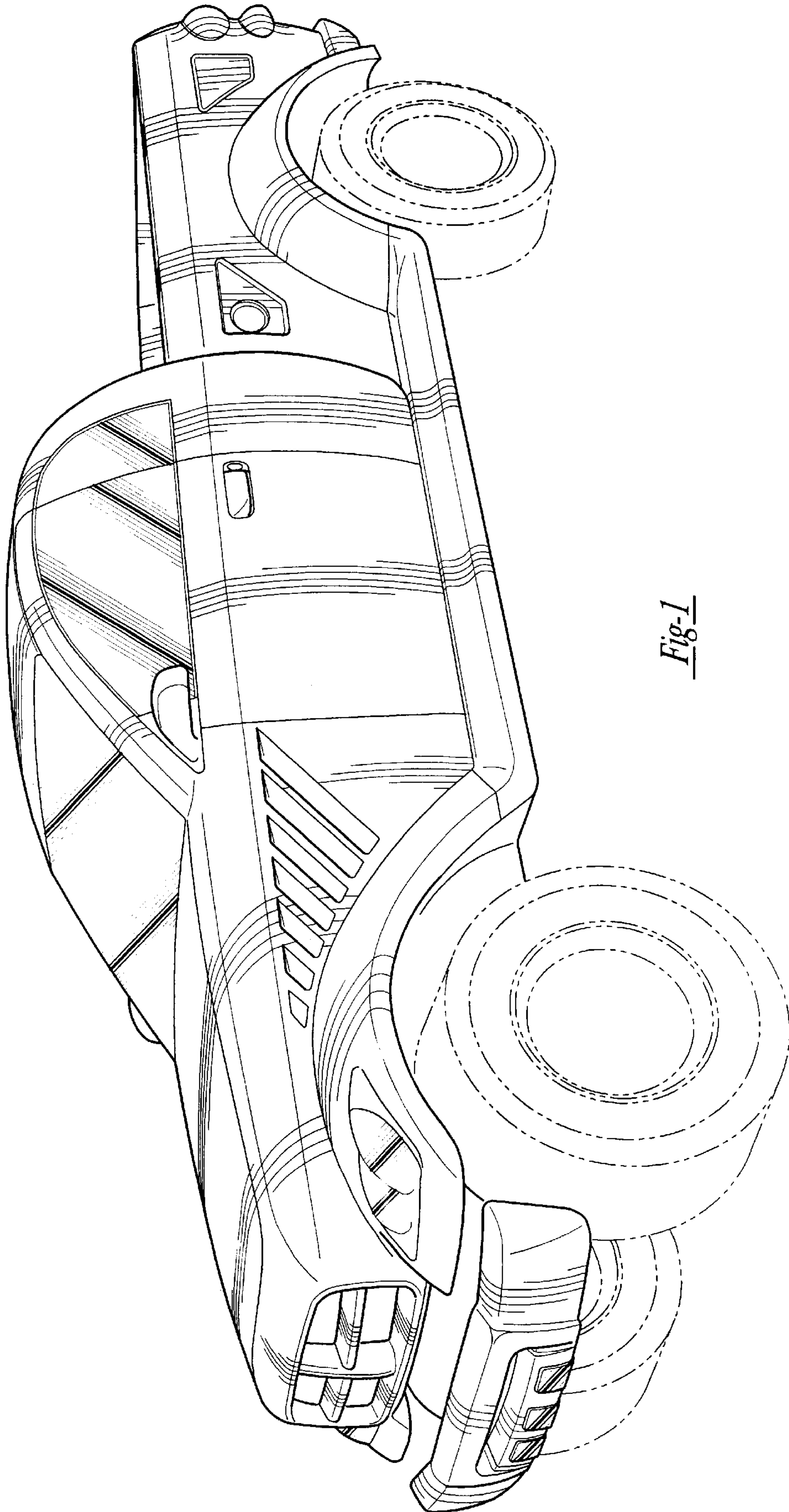

Fig-1

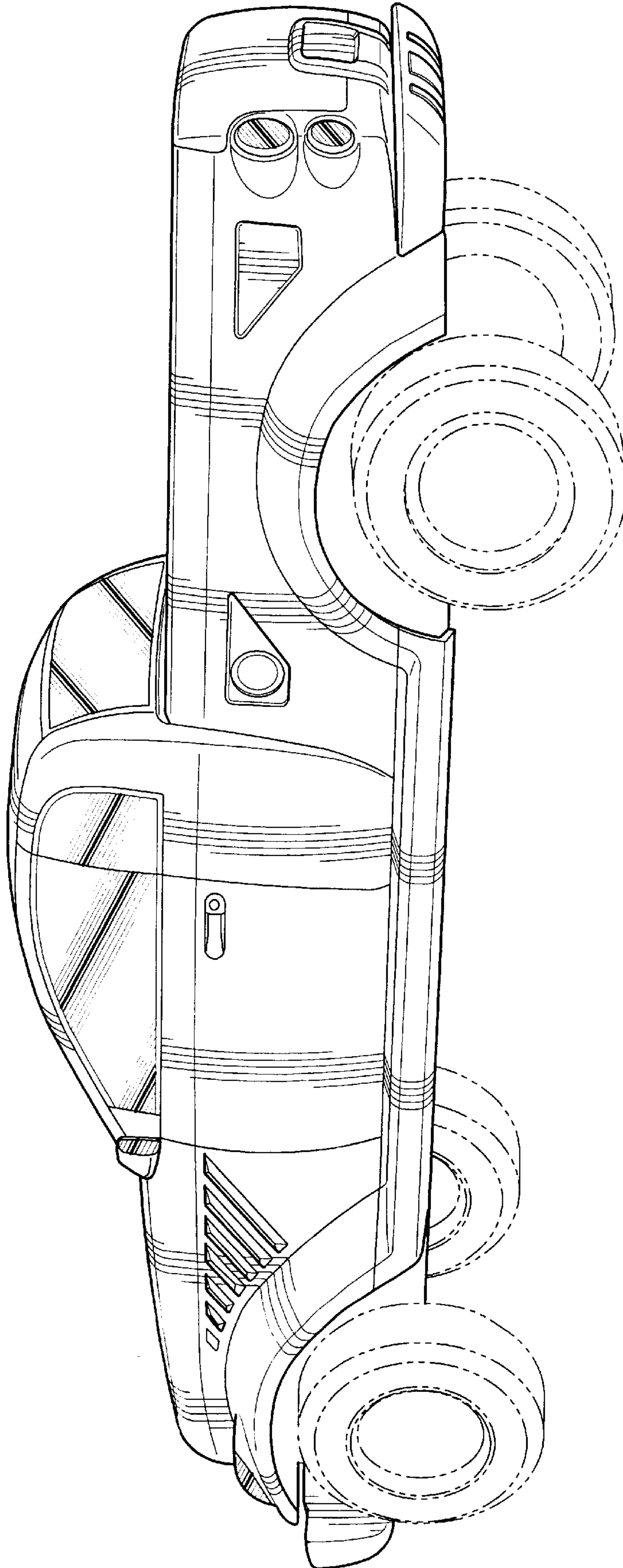

Fig-2

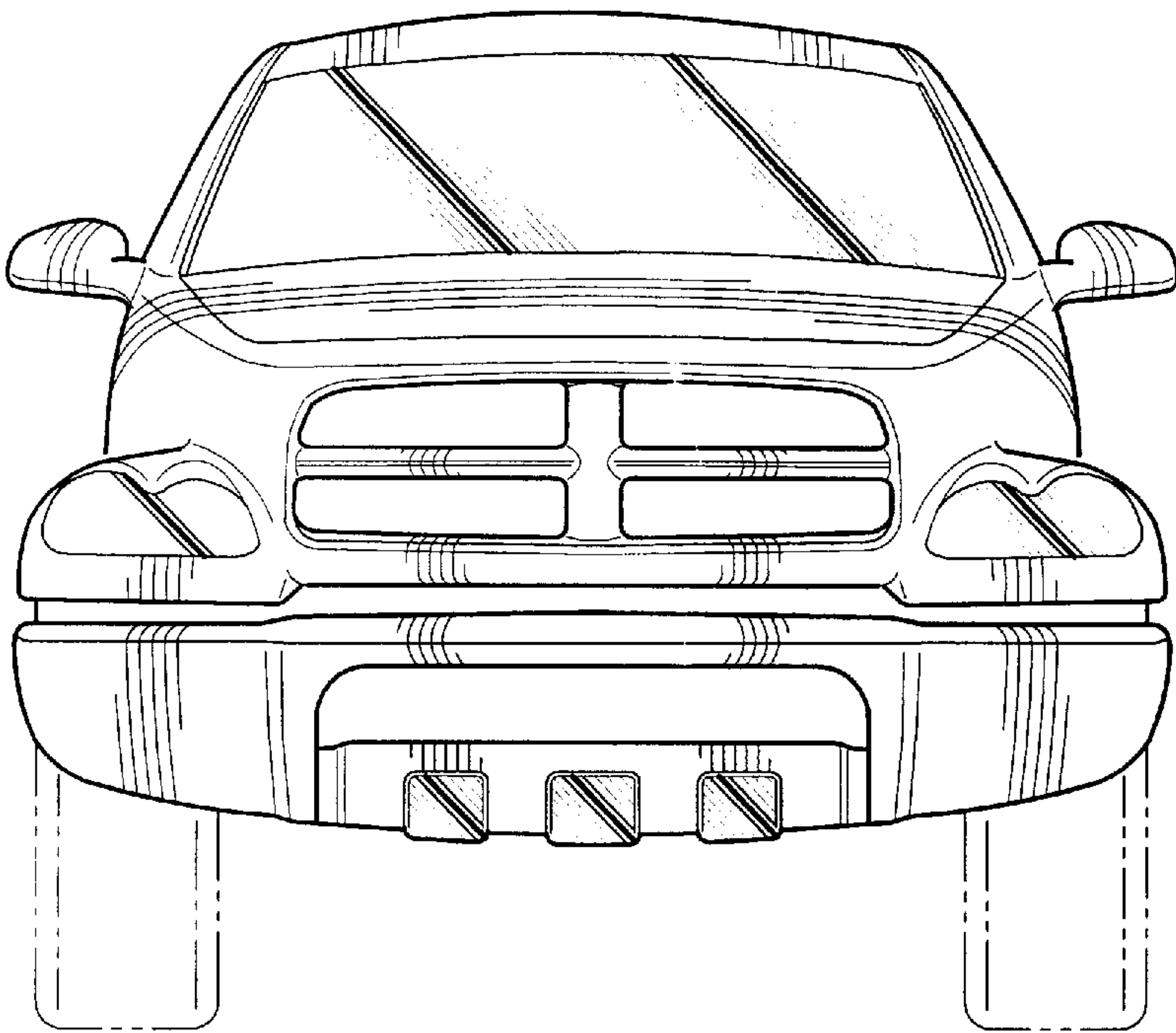

Fig-3

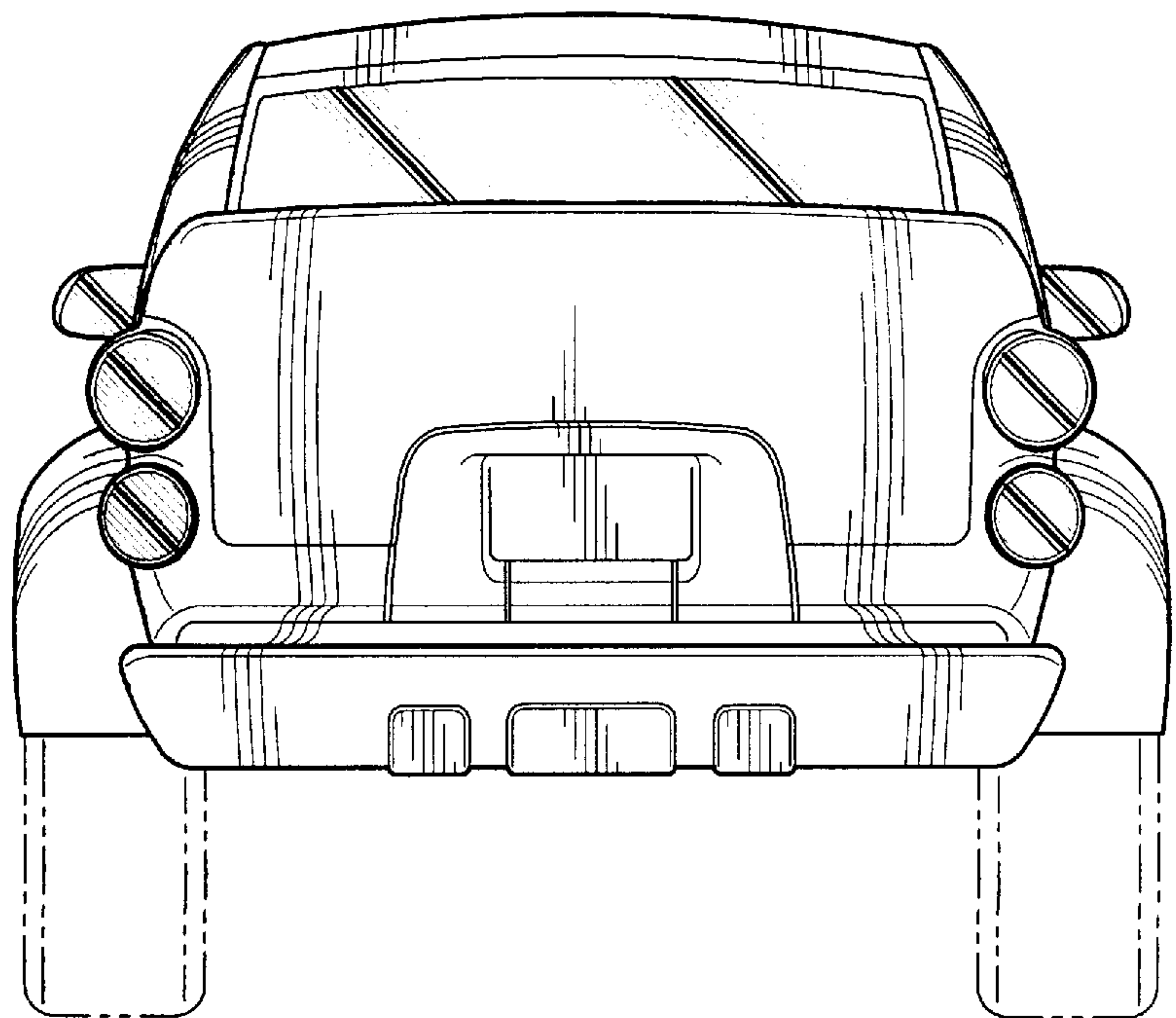

Fig-4