



US00D419486S

United States Patent [19]

Crain et al.

[11] **Patent Number: Des. 419,486**

[45] **Date of Patent: ** Jan. 25, 2000**

[54] **AUTOMOBILE BODY**

[75] Inventors: **John E. Crain**, Birmingham; **Osamu Shikado**, Auburn Hills, both of Mich.

[73] Assignee: **DaimlerChrysler Corporation**, Auburn Hills, Mich.

[**] Term: **14 Years**

[21] Appl. No.: **29/098,019**

[22] Filed: **Dec. 18, 1998**

[51] **LOC (7) Cl.** **12-08**

[52] **U.S. Cl.** **D12/91**

[58] **Field of Search** D12/90-92; 296/185

[56] **References Cited**

U.S. PATENT DOCUMENTS

- D. 391,522 3/1998 Hall et al. D12/92
- D. 392,920 3/1998 Verduyn et al. D12/91

- D. 394,420 5/1998 Forbeo-Robinson D12/92
- D. 405,389 2/1999 Frostle et al. D12/92
- D. 406,551 3/1999 Nesbutt D12/92

Primary Examiner—Melody N. Brown
Attorney, Agent, or Firm—Mark P. Calcaterra

[57] **CLAIM**

The ornamental design for an automobile body, as shown and described.

DESCRIPTION

FIG. 1 is a front perspective view illustrating an automobile body constructed in accordance with the teachings of the present invention.

FIG. 2 is a rear perspective view thereof.

FIG. 3 is a left view thereof, the opposite side being a substantial mirror image.

FIG. 4 is a front view thereof.

FIG. 5 is a rear view thereof.

1 Claim, 4 Drawing Sheets

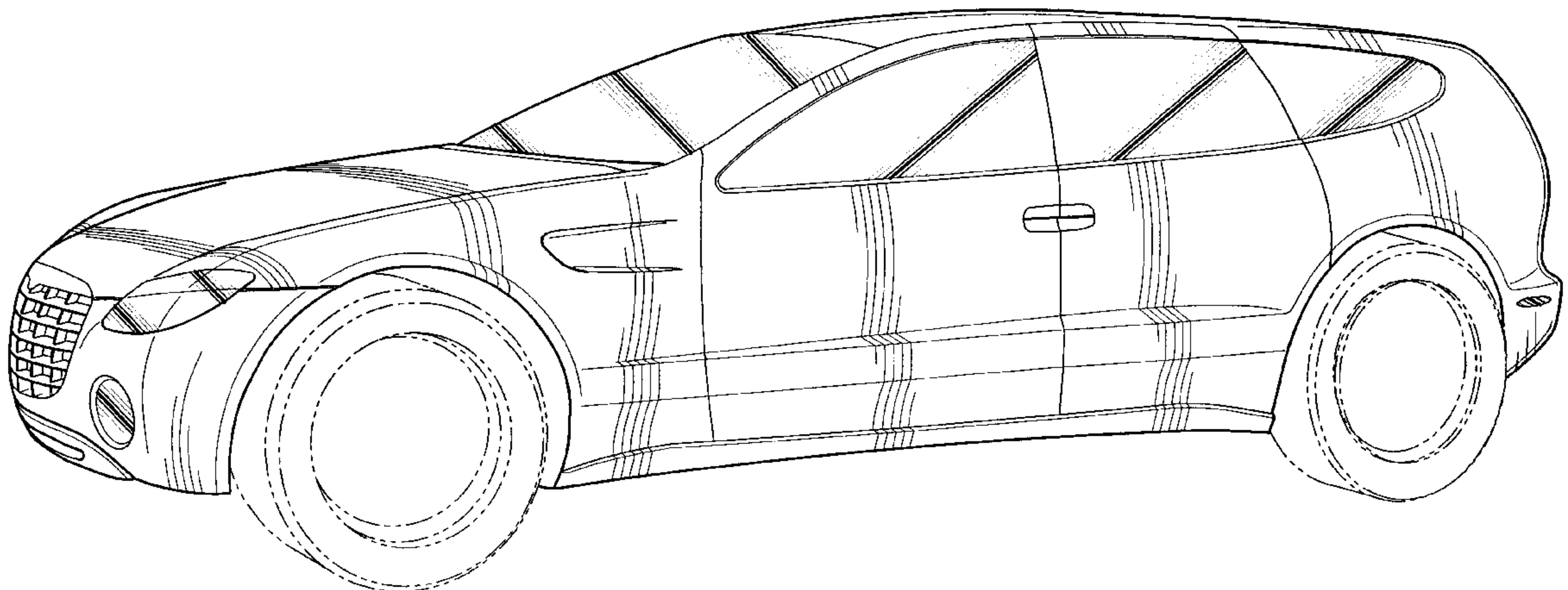

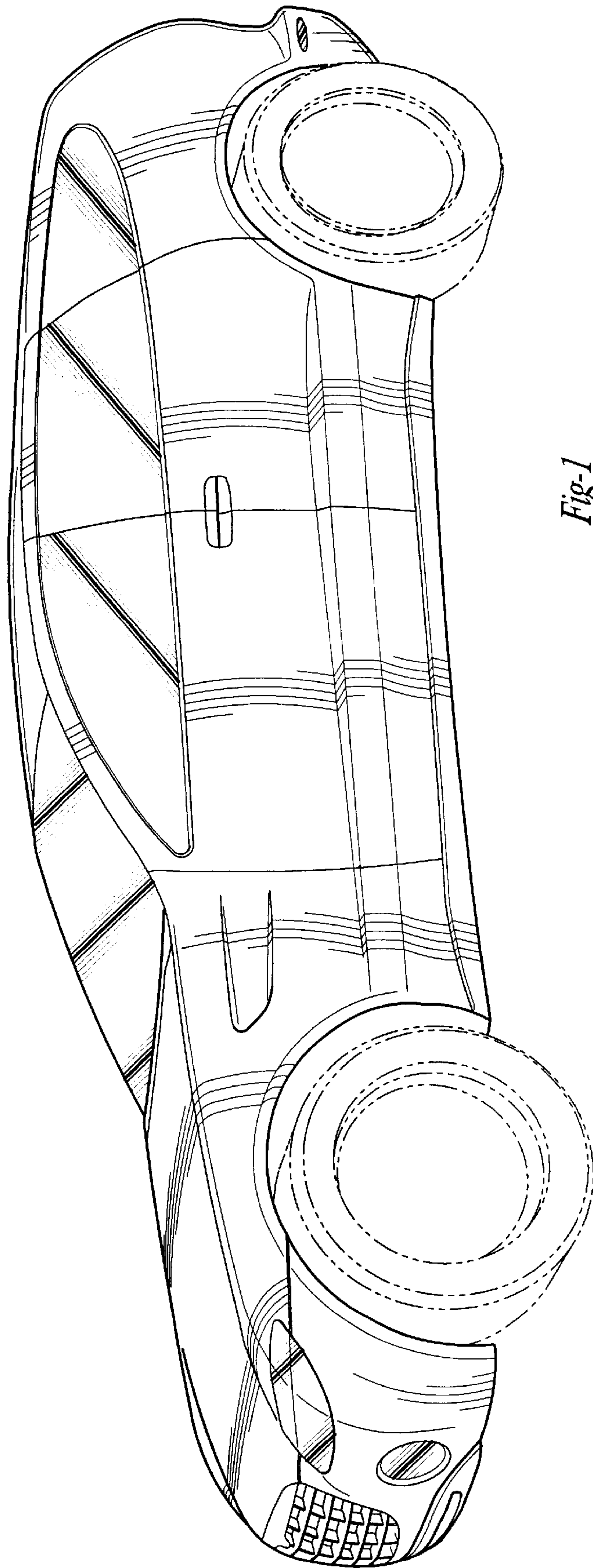

Fig-1

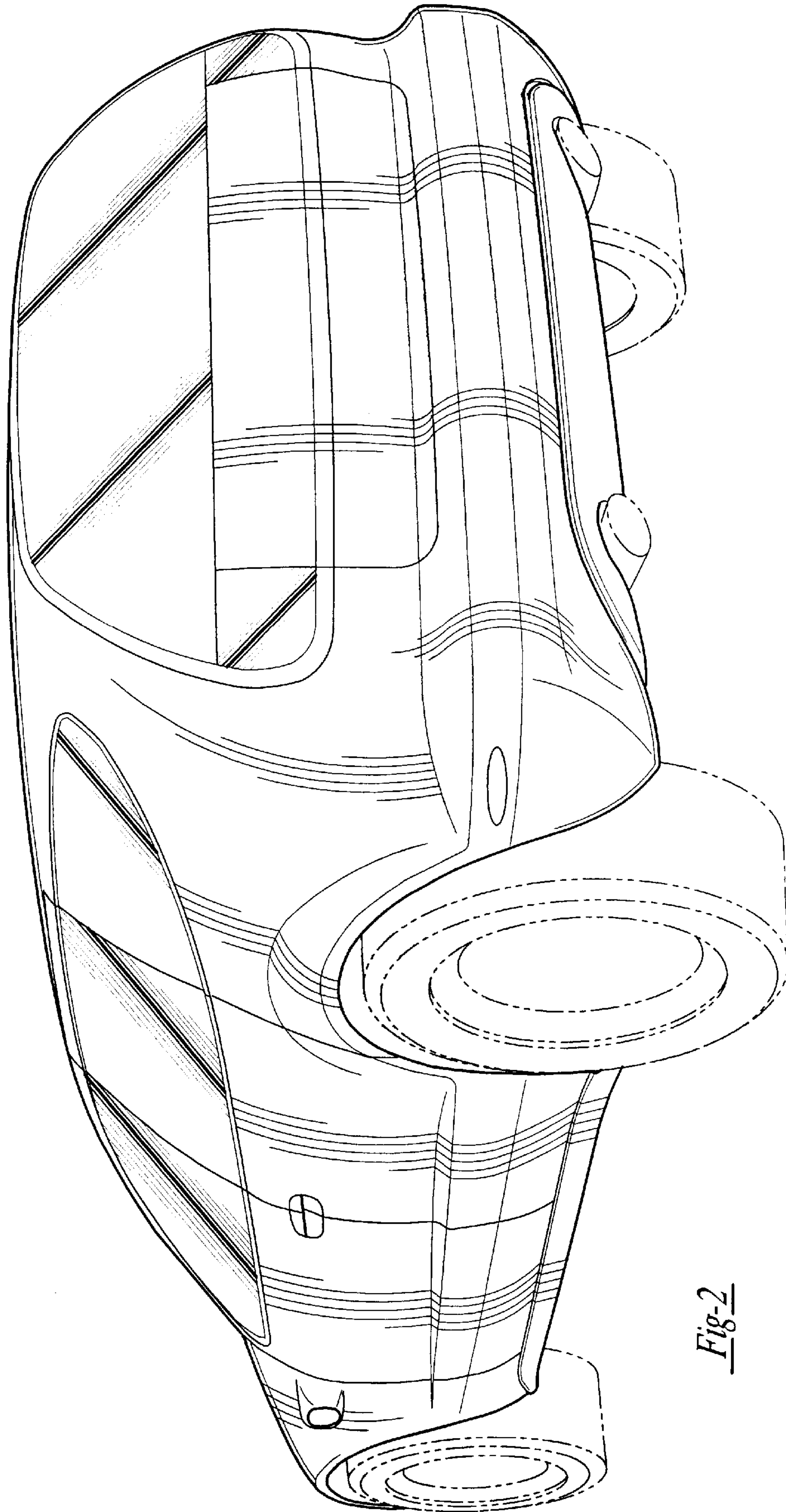

Fig-2

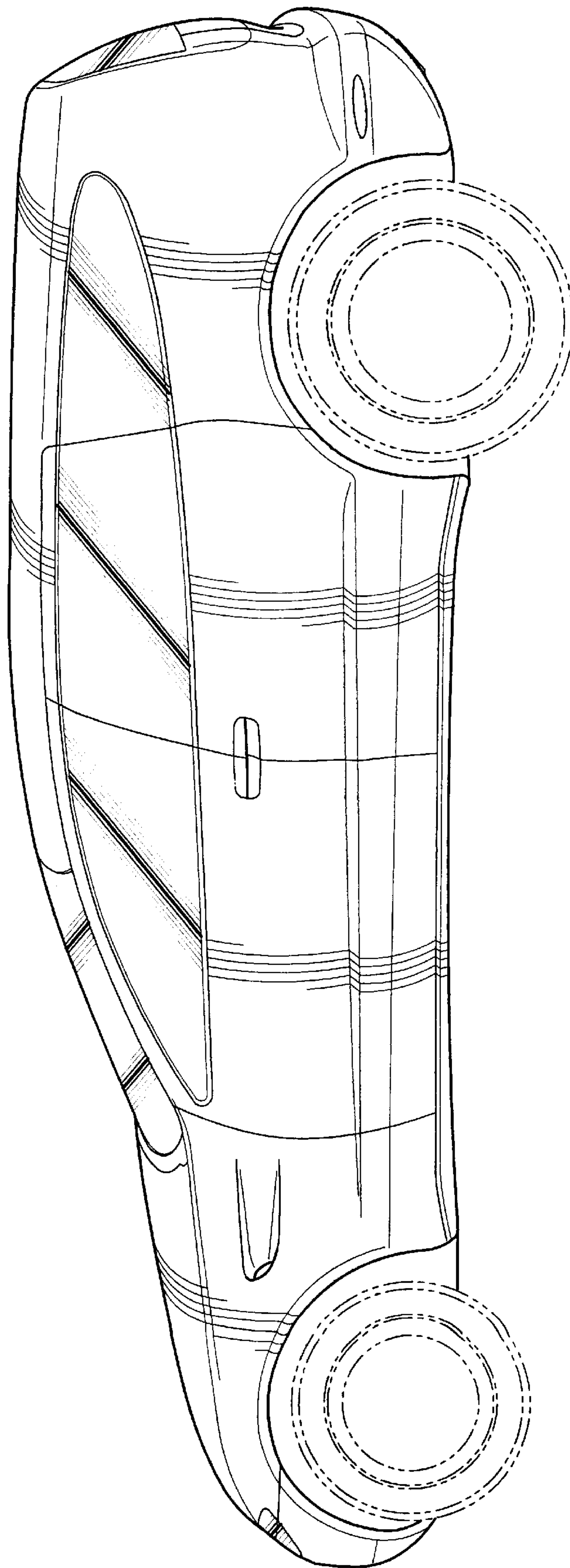

Fig-3

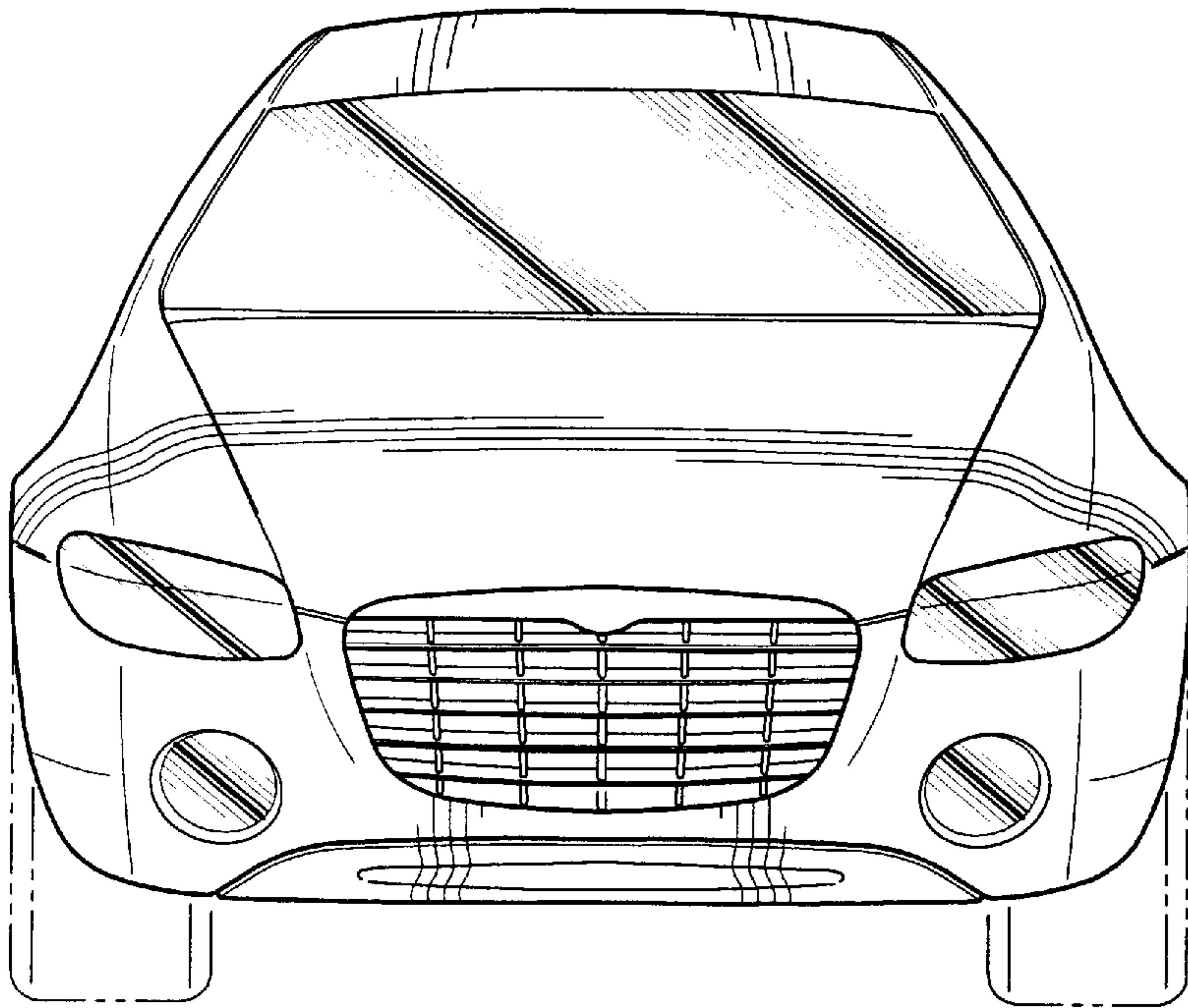

Fig-4

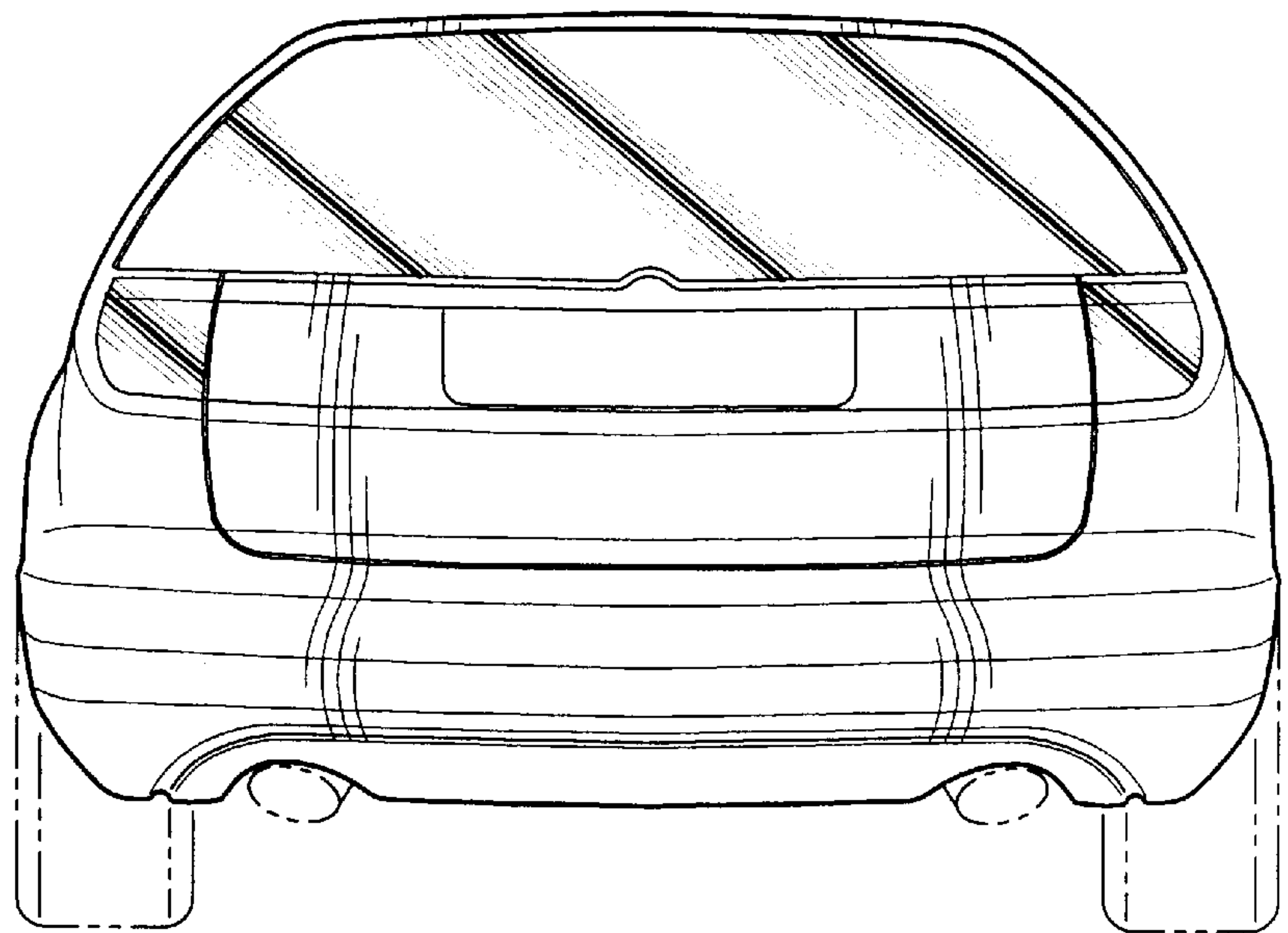

Fig-5