



US00D419424S

United States Patent [19]
Holden

[11] **Patent Number: Des. 419,424**
[45] **Date of Patent: ** Jan. 25, 2000**

[54] **WHEEL LOCK FOR VEHICLES,
AIRPLANES, AND THE LIKE**
[75] Inventor: **Kenneth M. Holden**, Buellton, Calif.
[73] Assignee: **California Immobilizer**, Palmdale,
Calif.
[**] Term: **14 Years**
[21] Appl. No.: **29/096,375**
[22] Filed: **Nov. 9, 1998**
[51] **LOC (7) Cl.** **08-07**
[52] **U.S. Cl.** **D8/341; D8/330**
[58] **Field of Search** 224/42.25, 47.26;
70/225, 226, 14, 259, 258, 260, 18; D8/330,
331, 339, 341

5,689,981 11/1997 DeLuca et al. 70/226
5,833,034 11/1998 Banholzer 70/226 X
5,927,108 7/1999 Pierce 70/226 X

Primary Examiner—Susan J. Lucas
Assistant Examiner—Jennifer Rivard
Attorney, Agent, or Firm—Willie Krawitz

[57] **CLAIM**

The ornamental design for a wheel lock for vehicles, air-
planes, and the like, as shown and described.

DESCRIPTION

FIG. 1 is a perspective view of a wheel lock for vehicles,
airplanes, and the like, showing my design;
FIG. 2 is a top plan thereof;
FIG. 3 is a front elevation view thereof;
FIG. 4 is a bottom plan view thereof;
FIG. 5 is a left elevation view thereof; and,
FIG. 6 is a right elevation view thereof.
The broken lines are shown for illustrative purposes only
and form no part of the claimed design.

[56] **References Cited**

U.S. PATENT DOCUMENTS

4,651,849 3/1987 Givati 70/225 X
5,134,868 8/1992 Bethards 70/18

1 Claim, 2 Drawing Sheets

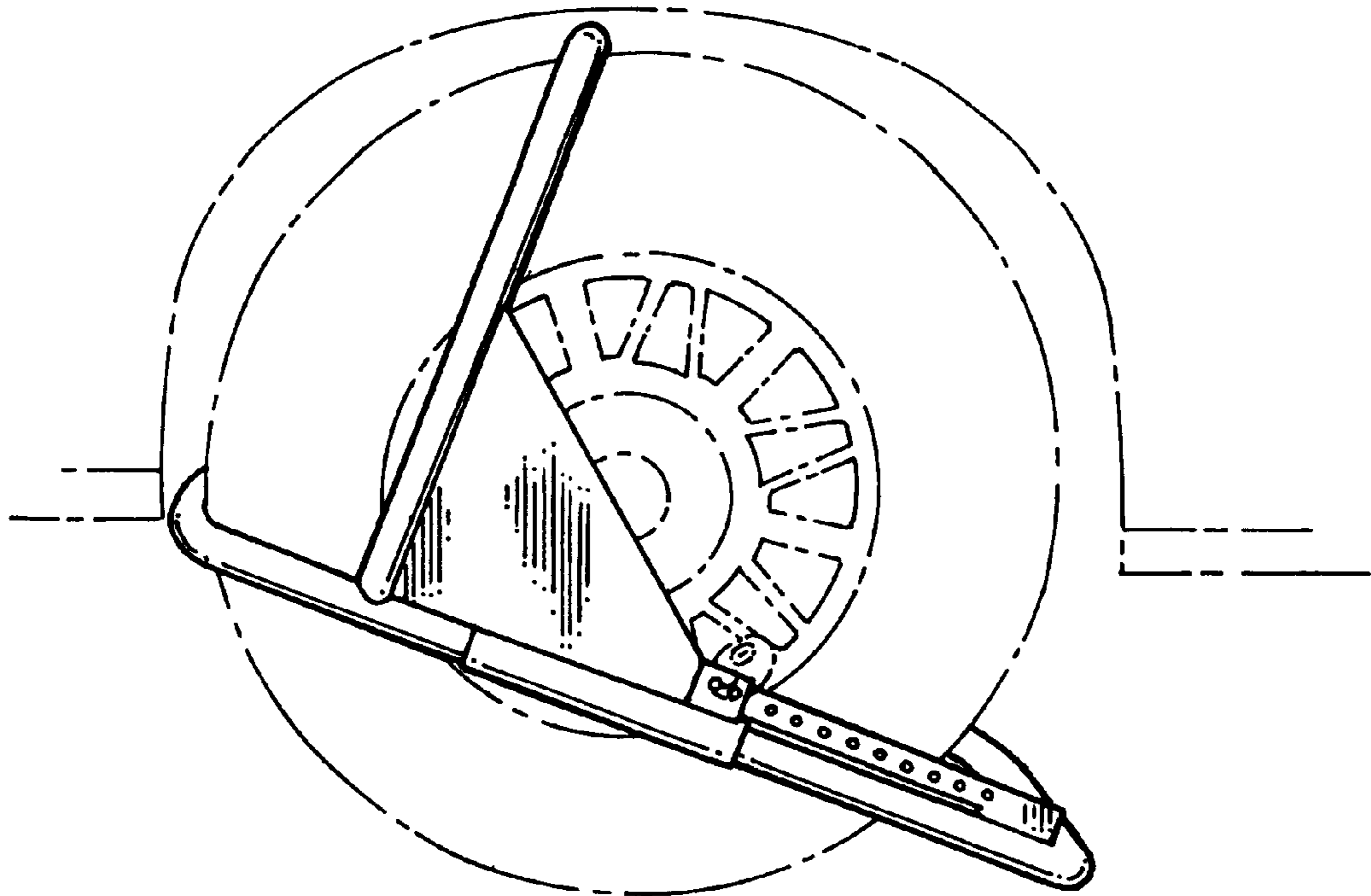

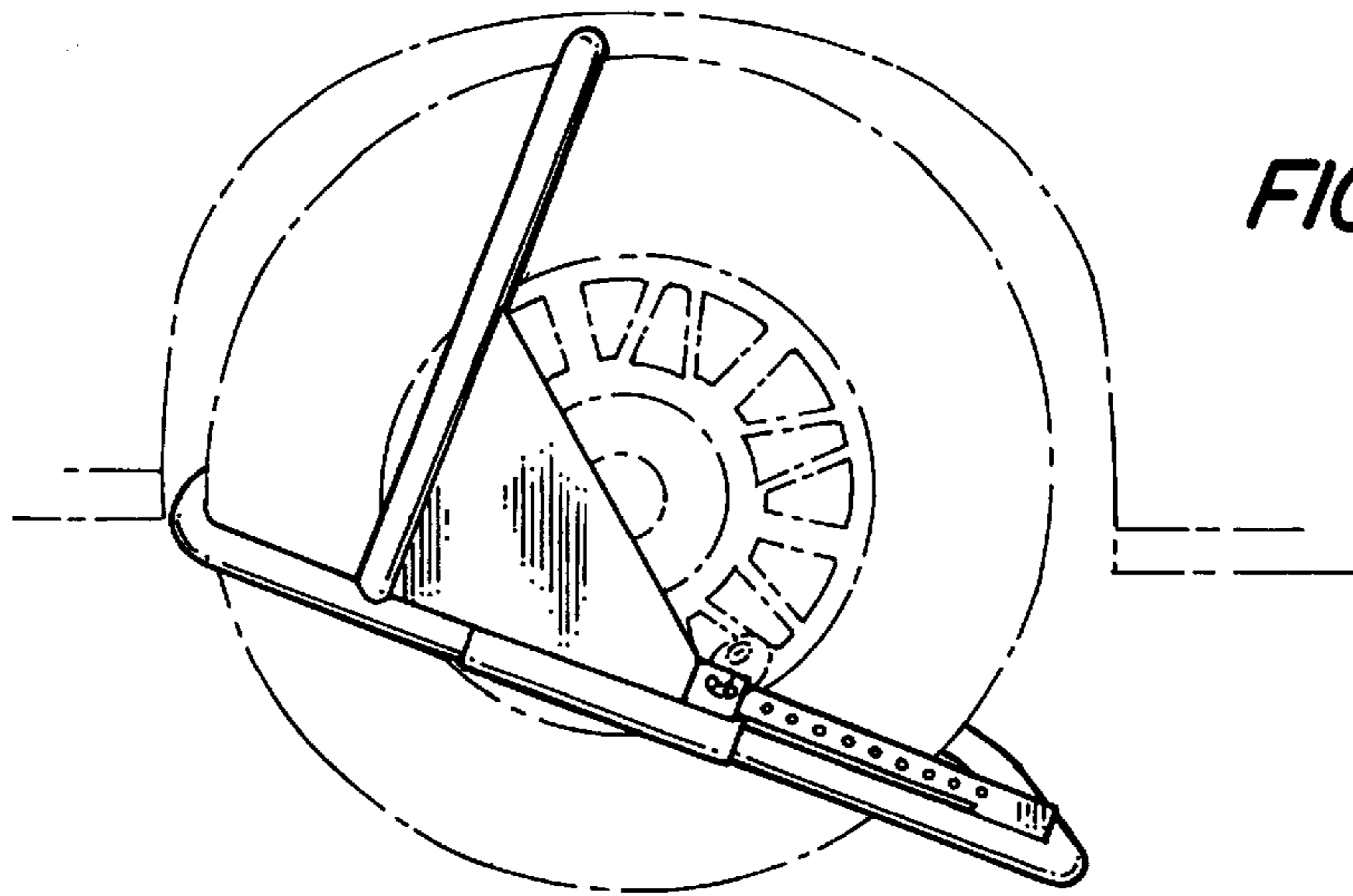

FIG. 1

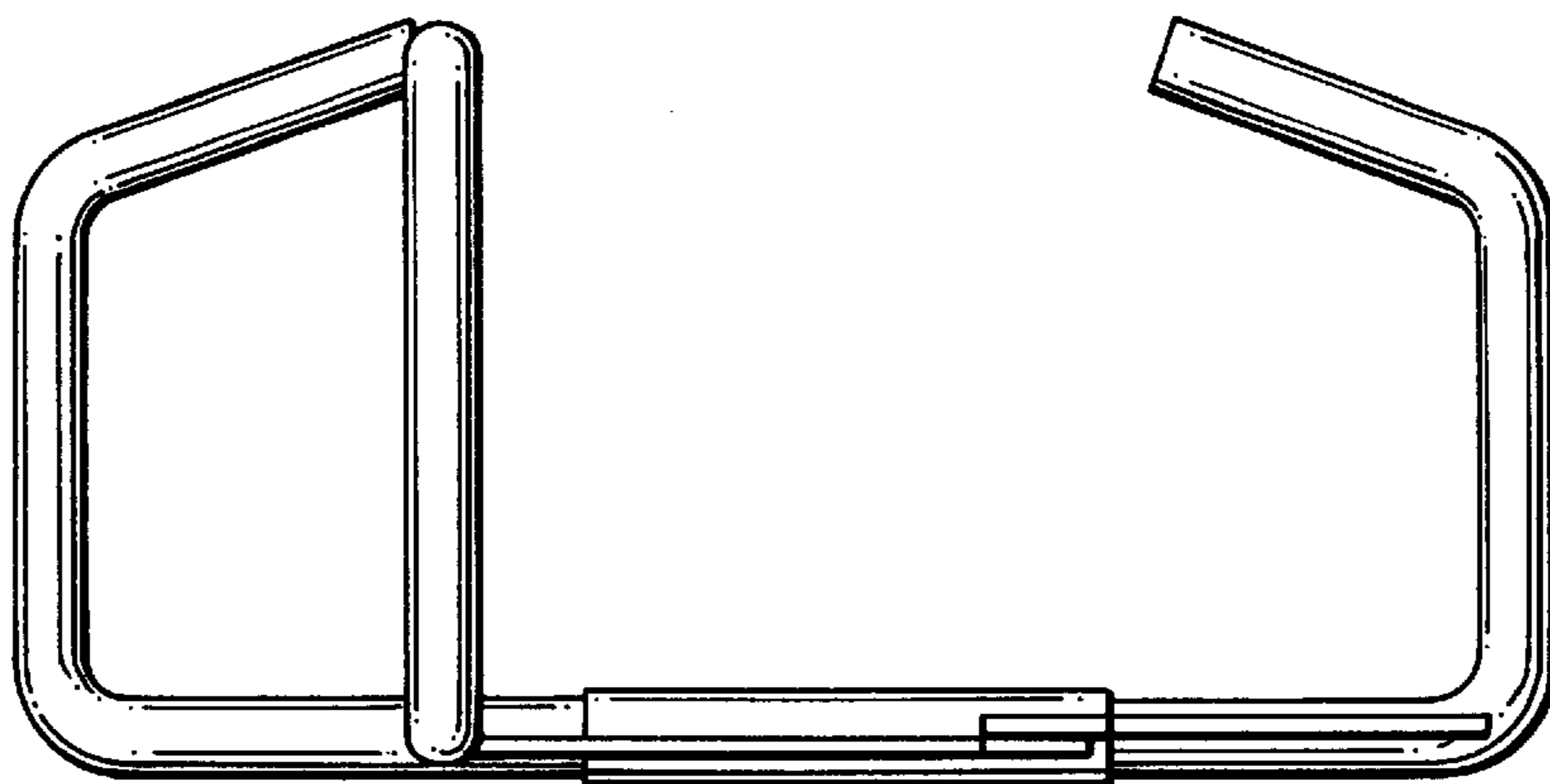

FIG. 2

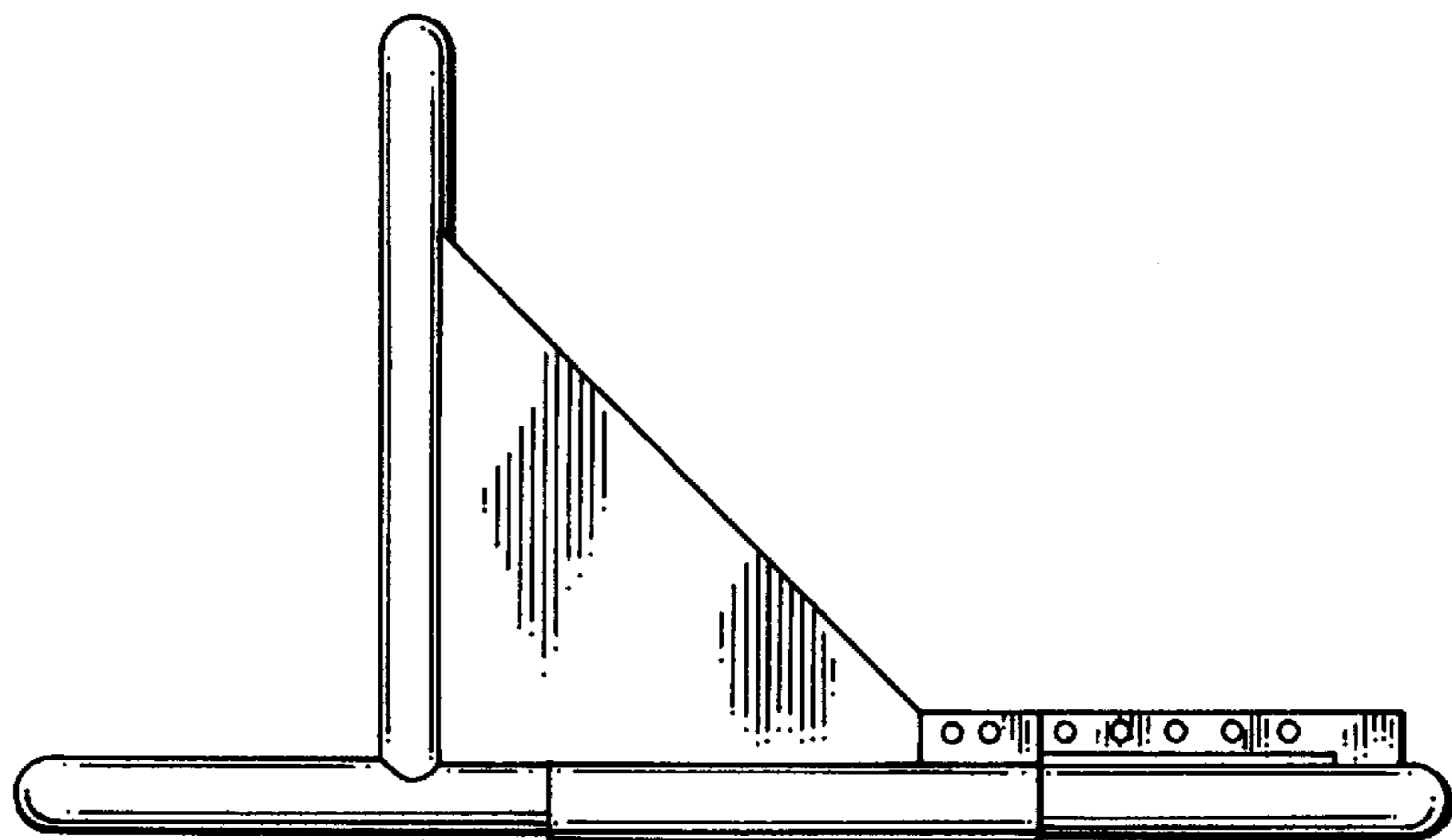

FIG. 3

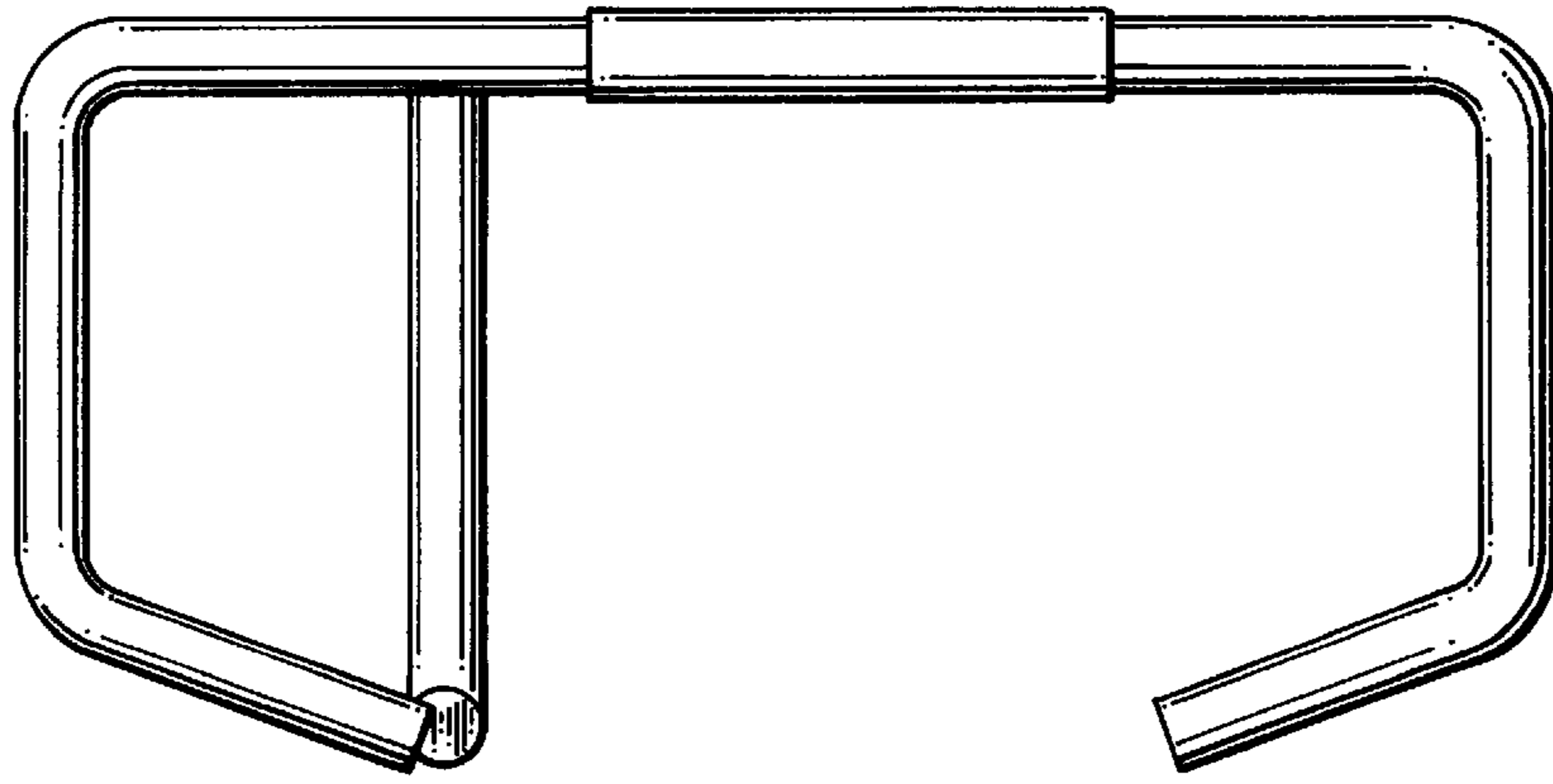

FIG. 4

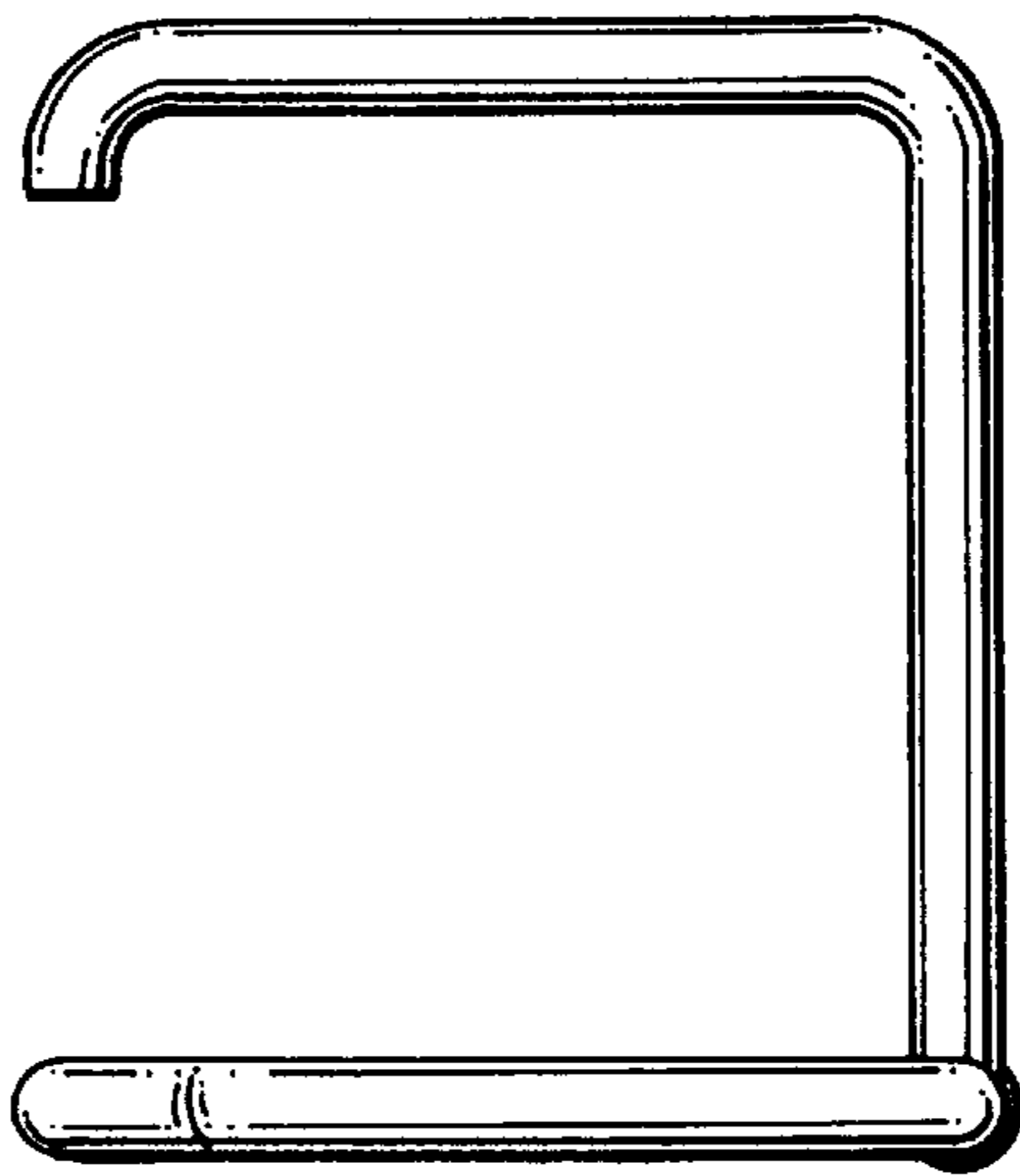

FIG. 5

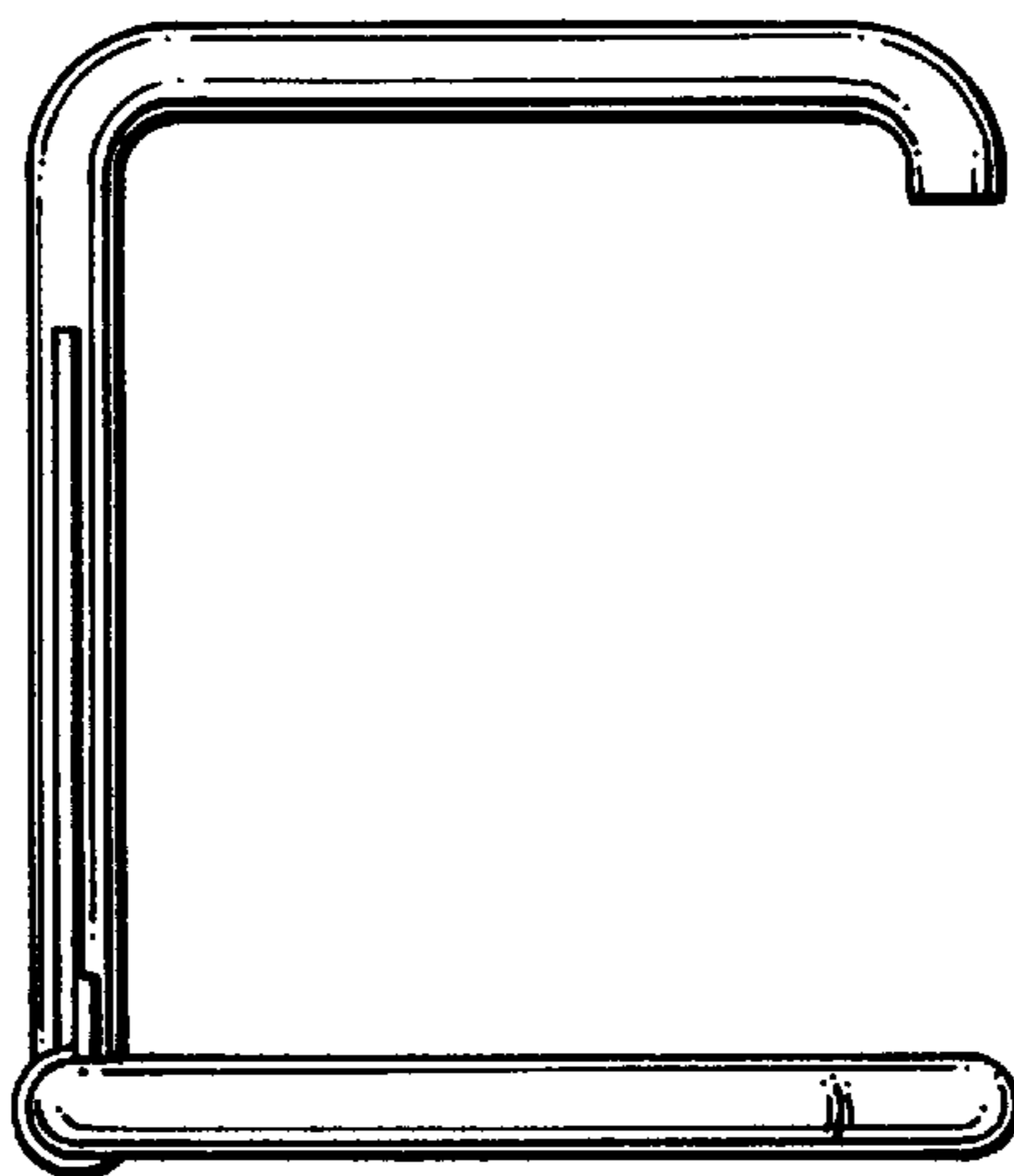

FIG. 6