



US00D419085S

**United States Patent** [19]  
**Prus**

[11] **Patent Number: Des. 419,085**

[45] **Date of Patent: \*\* Jan. 18, 2000**

[54] **TIRE VALVE STEM PRESSURE GAUGE**

[57] **CLAIM**

[76] **Inventor: Robert S Prus, 2630 Vermillion Rd., Seabrook, Tex. 77586**

The ornamental design for a tire valve stem pressure gauge, as shown.

[\*\*] **Term: 14 Years**

**DESCRIPTION**

[21] **Appl. No.: 29/097,045**

FIG. 1 is a top plan view of the tire valve stem pressure gauge of the present invention;  
FIG. 2 is a bottom plan view of the tire valve stem pressure gauge of FIG. 1;  
FIG. 3 is a left side elevational view of the tire valve stem pressure gauge of FIG. 1;  
FIG. 4 is a right side elevational view of the tire valve stem pressure gauge of FIG. 1;  
FIG. 5 is a front elevational view of the tire valve stem pressure gauge of FIG. 1;  
FIG. 6 is a back elevational view of the tire valve stem pressure gauge of FIG. 1;  
FIG. 7 is a top, front, right side perspective view of the tire valve stem pressure gauge of FIG. 1; and,  
FIG. 8 is a bottom, back, left side perspective view of the tire valve stem pressure gauge of FIG. 1.

[22] **Filed: Nov. 25, 1998**

[51] **LOC (7) Cl. .... 10-04**

[52] **U.S. Cl. .... D10/86**

[58] **Field of Search ..... D10/86; 78/146.8, 78/146.6; 116/342**

[56] **References Cited**

**U.S. PATENT DOCUMENTS**

- D. 192,262 2/1962 Trinca ..... D10/86
- D. 335,465 5/1993 Garrison, III ..... D10/86

*Primary Examiner*—Antoine Duval Davis

**1 Claim, 3 Drawing Sheets**

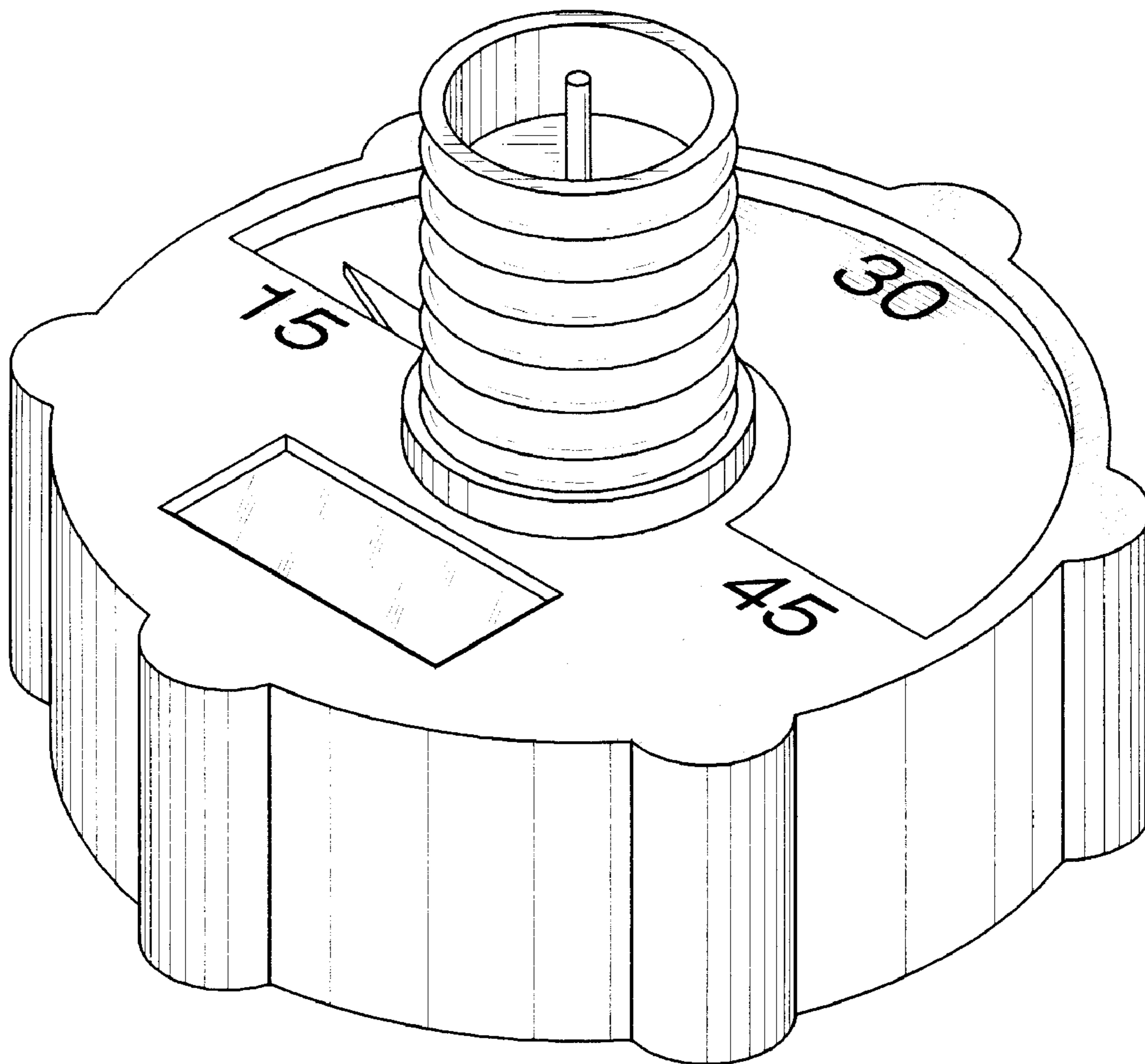

FIG. 1

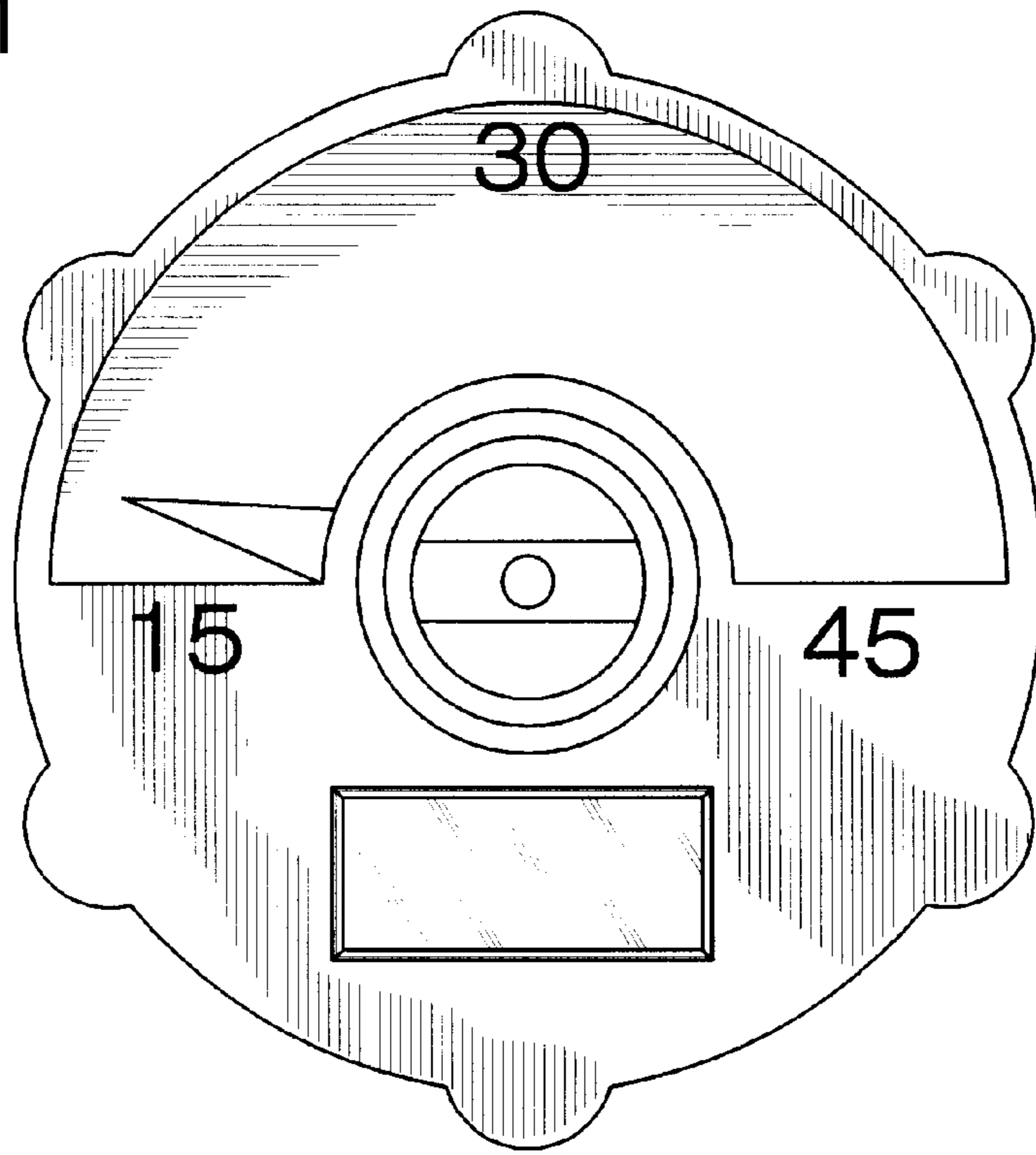
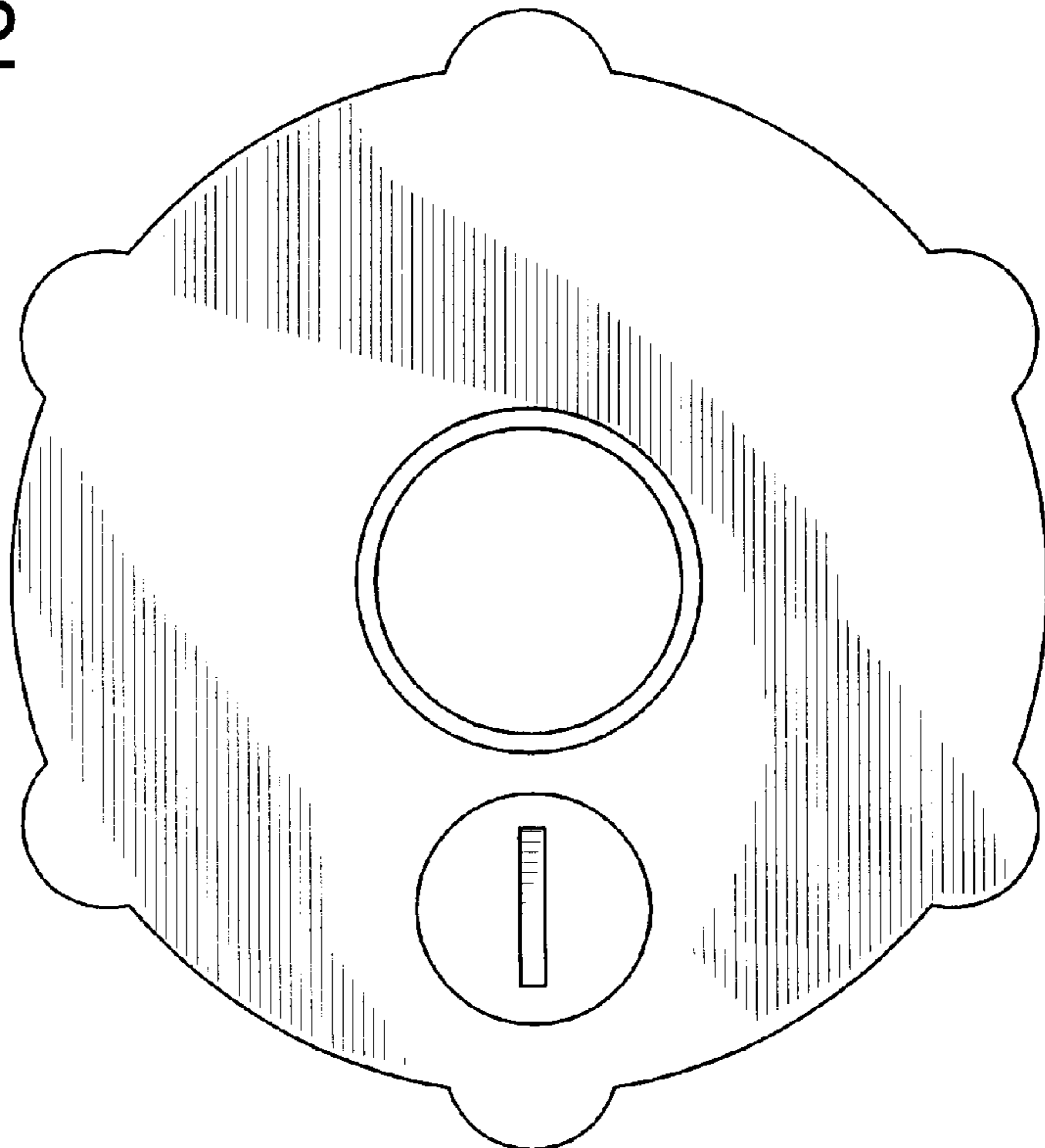

FIG. 2



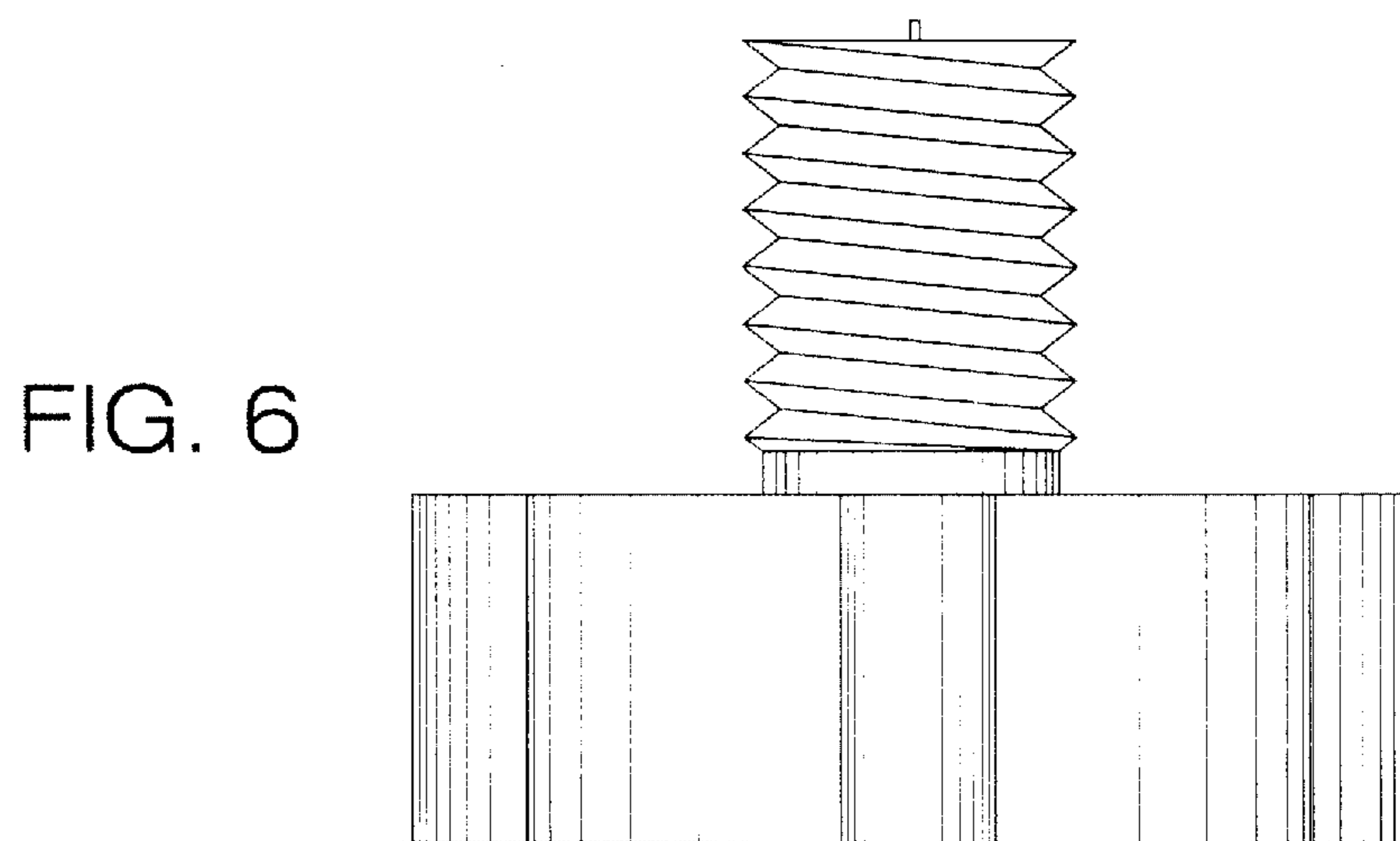
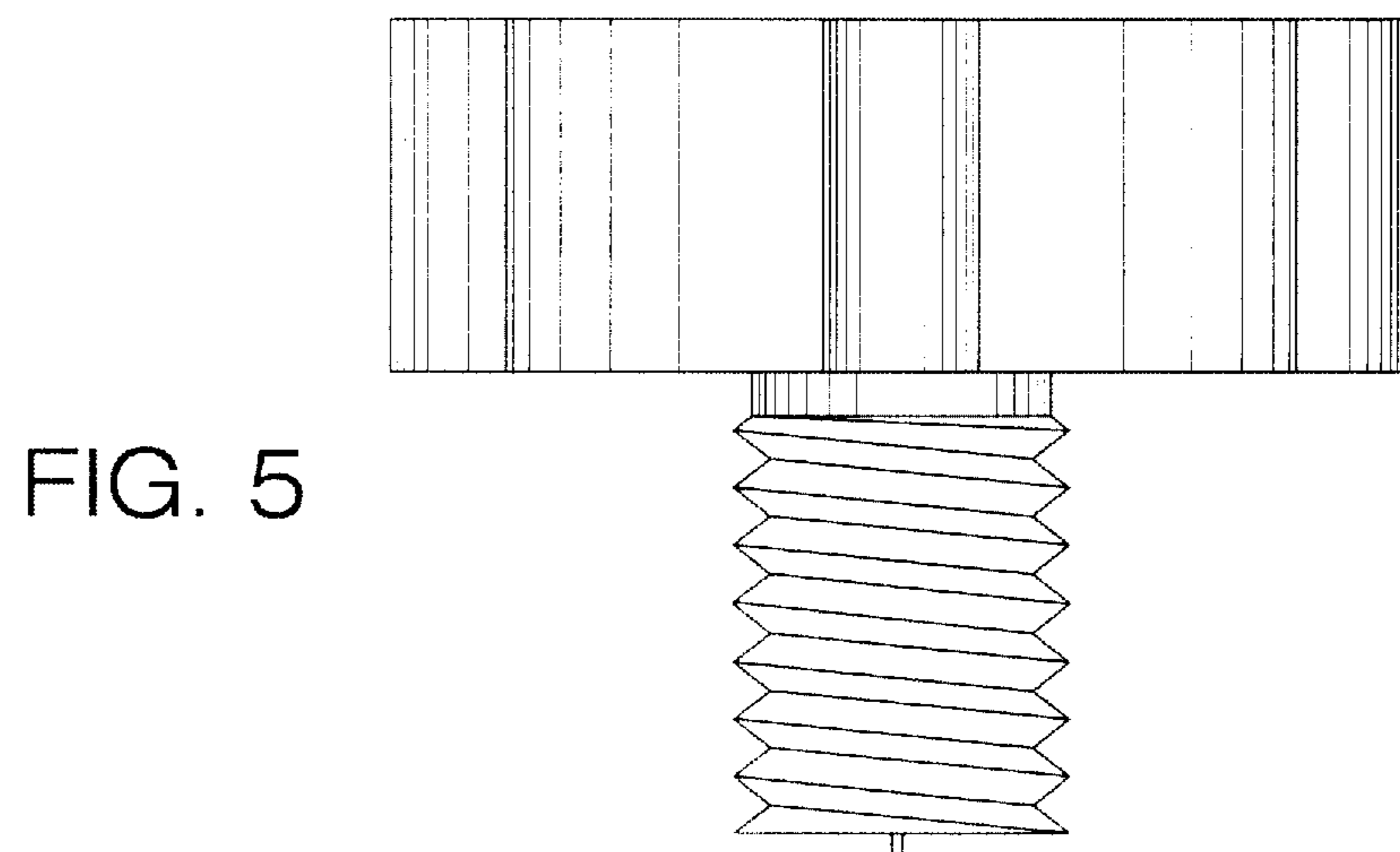
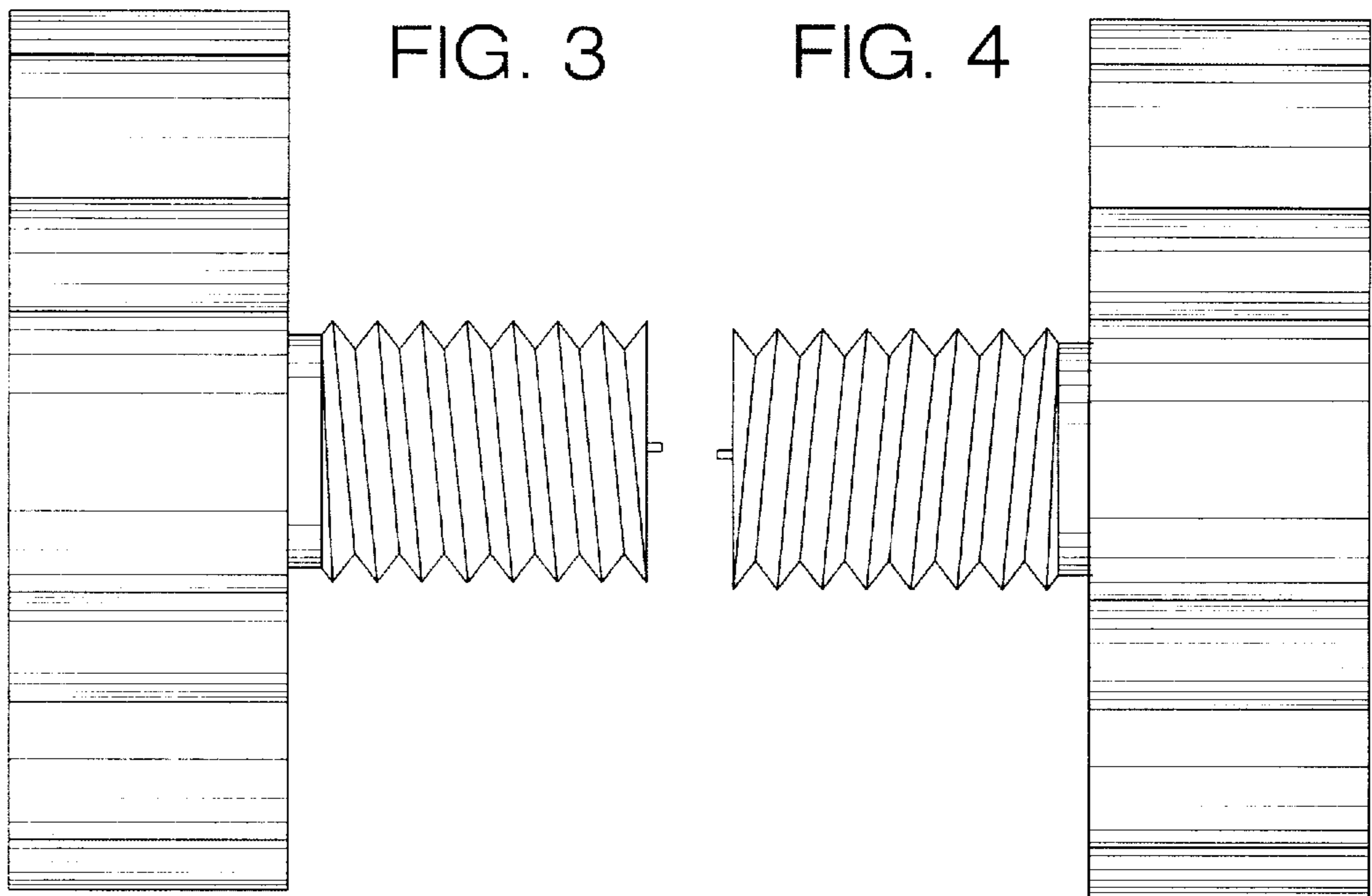

FIG. 7

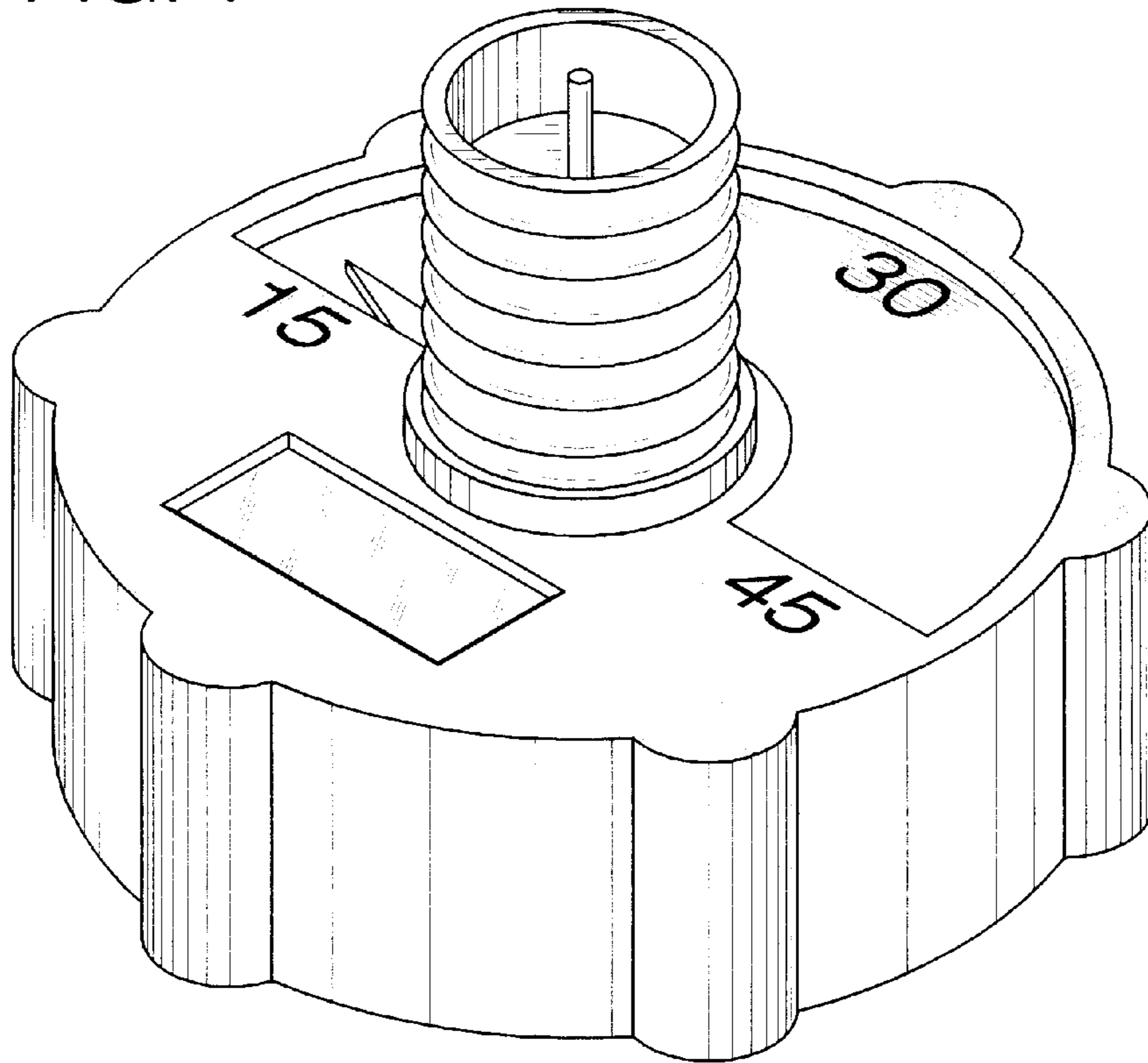

FIG. 8

