



US00D418513S

United States Patent [19]

Suzuki et al.

[11] Patent Number: **Des. 418,513**

[45] Date of Patent: **** Jan. 4, 2000**

[54] **MICROPHONE**

[75] Inventors: **Satoshi Suzuki; Hirohisa Tanaka**, both of Tokyo, Japan

[73] Assignee: **Sony Corporation**, Tokyo, Japan

[**] Term: **14 Years**

[21] Appl. No.: **29/092,376**

[22] Filed: **Aug. 18, 1998**

[51] **LOC (7) Cl.** **14-01**

[52] **U.S. Cl.** **D14/228**

[58] **Field of Search** D14/206, 223-229, D14/299; 181/158, 242, 299; 379/430, 431; 381/91, 168, 169

[56] **References Cited**

U.S. PATENT DOCUMENTS

D. 265,647	8/1982	Liataud	D14/225
D. 292,701	11/1987	Drever	D14/228
D. 299,338	1/1989	Wiegel	D14/225 X
1,678,842	7/1928	Aiken	181/242 X
3,027,423	3/1962	Reinthaler	D14/228 X

OTHER PUBLICATIONS

Sony Catalog "86", pp. 269, (Jul., 1997).

Primary Examiner—Nanda Bondade
Attorney, Agent, or Firm—Foley & Lardner

[57] **CLAIM**

The ornamental design for a microphone, as shown and described.

DESCRIPTION

FIG. 1 is a perspective view of a first embodiment of a microphone showing our new design;

FIG. 2 is a top plan view thereof;

FIG. 3 is a left side elevational view thereof;

FIG. 4 is a front elevational view thereof;

FIG. 5 is a right side elevational view thereof;

FIG. 6 is a bottom plan view thereof; and

FIG. 7 is a rear elevational view thereof;

FIG. 8 is a perspective view of a second embodiment of a microphone showing our new design;

FIG. 9 is a top plan view thereof;

FIG. 10 is a left side elevational view thereof;

FIG. 11 is a front elevational view thereof;

FIG. 12 is a right side elevational view thereof;

FIG. 13 is a bottom plan view thereof; and,

FIG. 14 is a rear elevational view thereof.

1 Claim, 14 Drawing Sheets

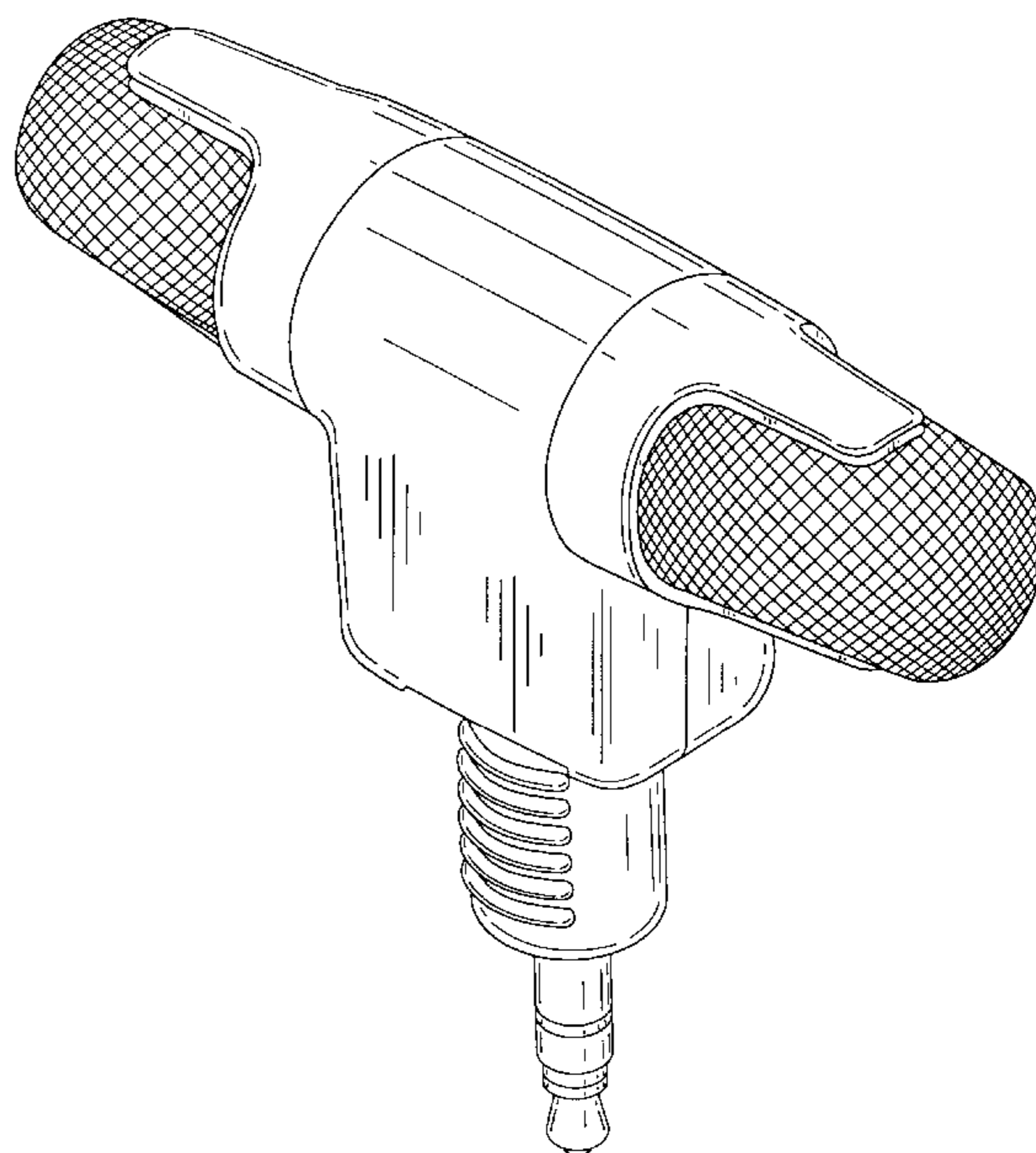
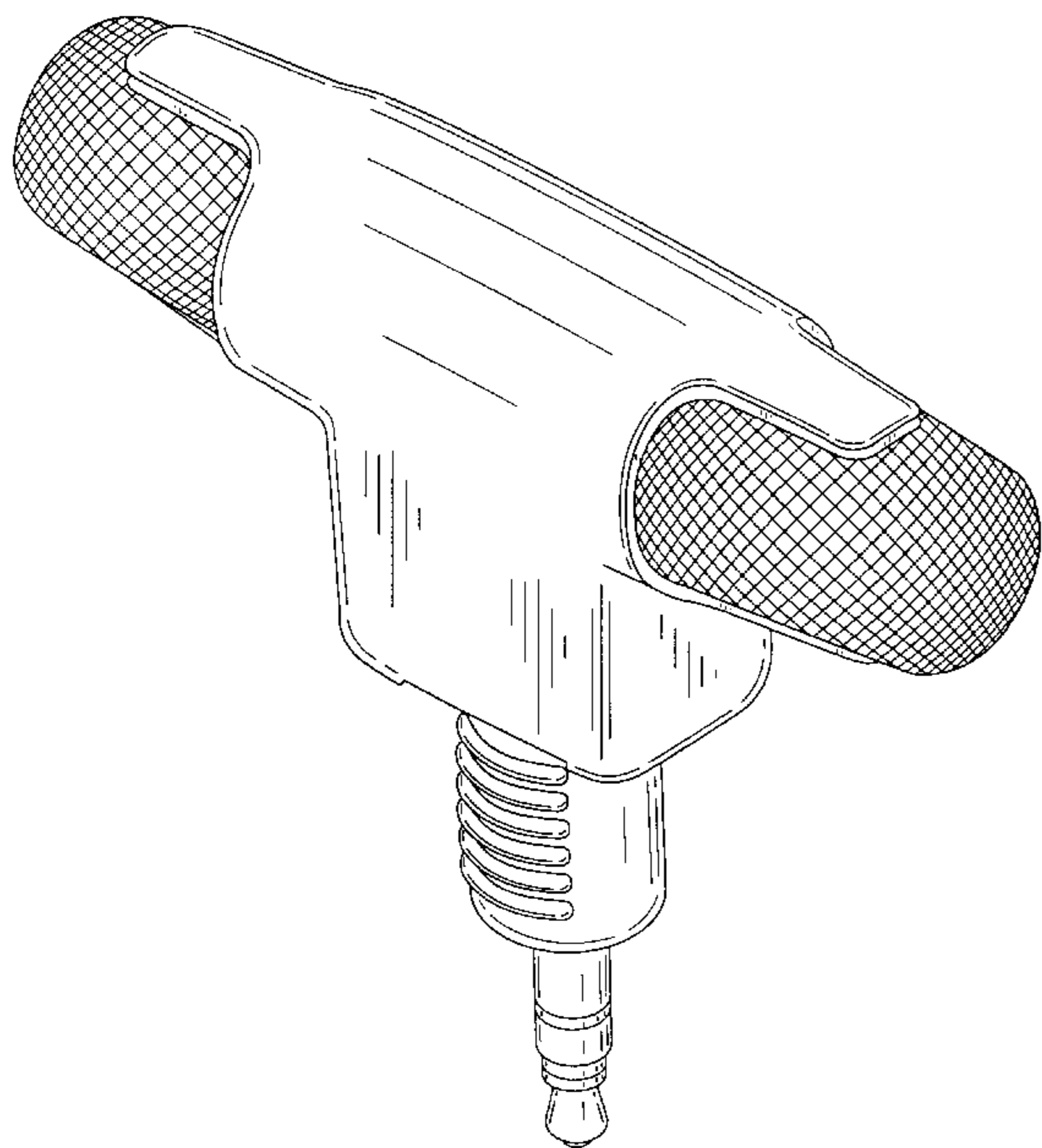

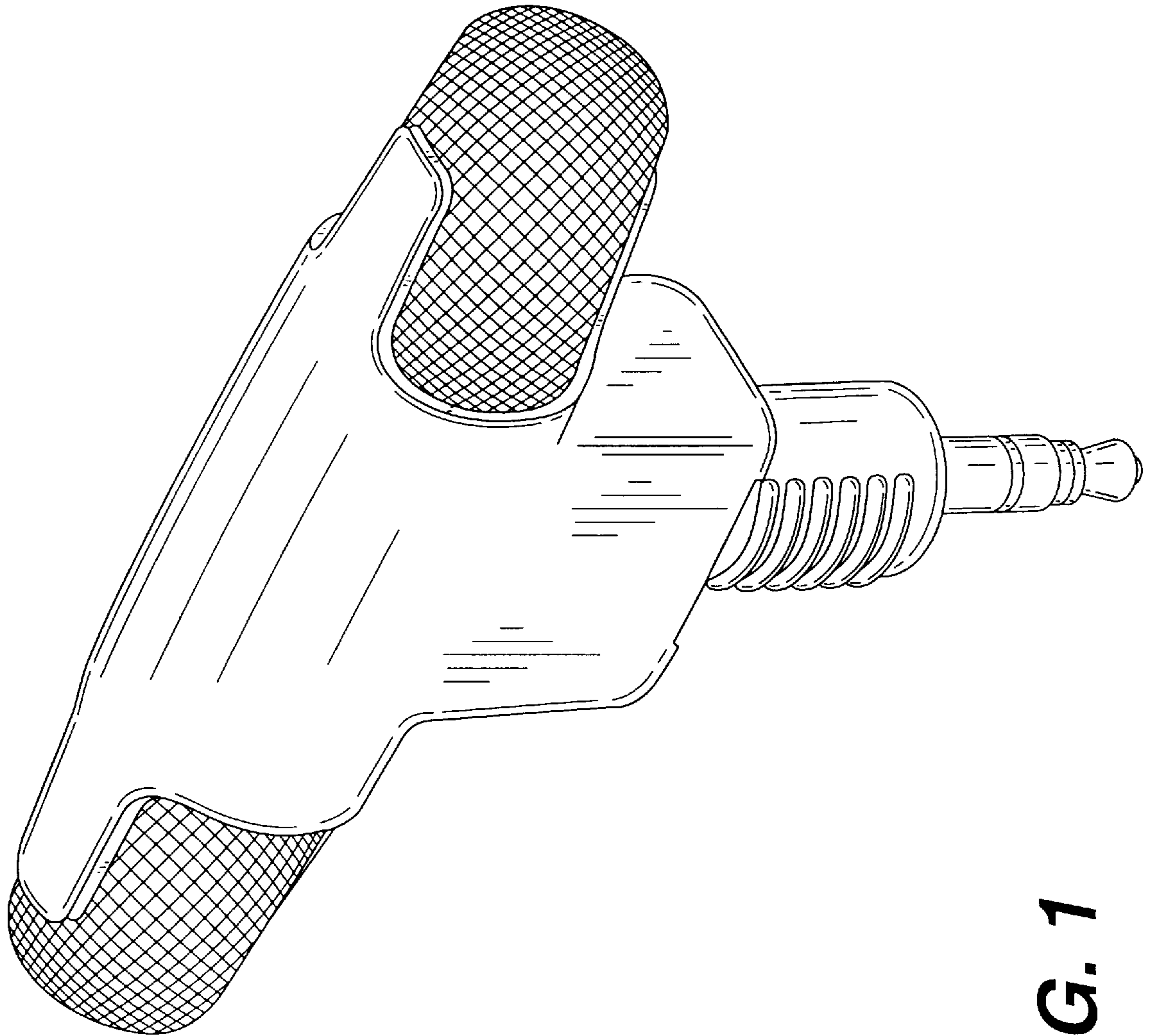

FIG. 1

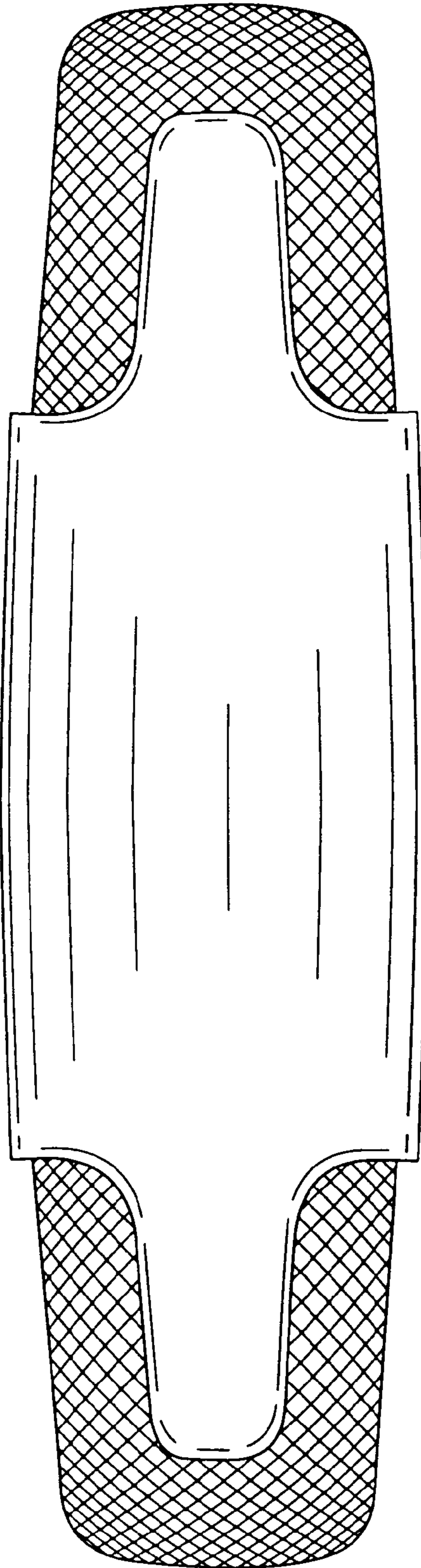

FIG. 2

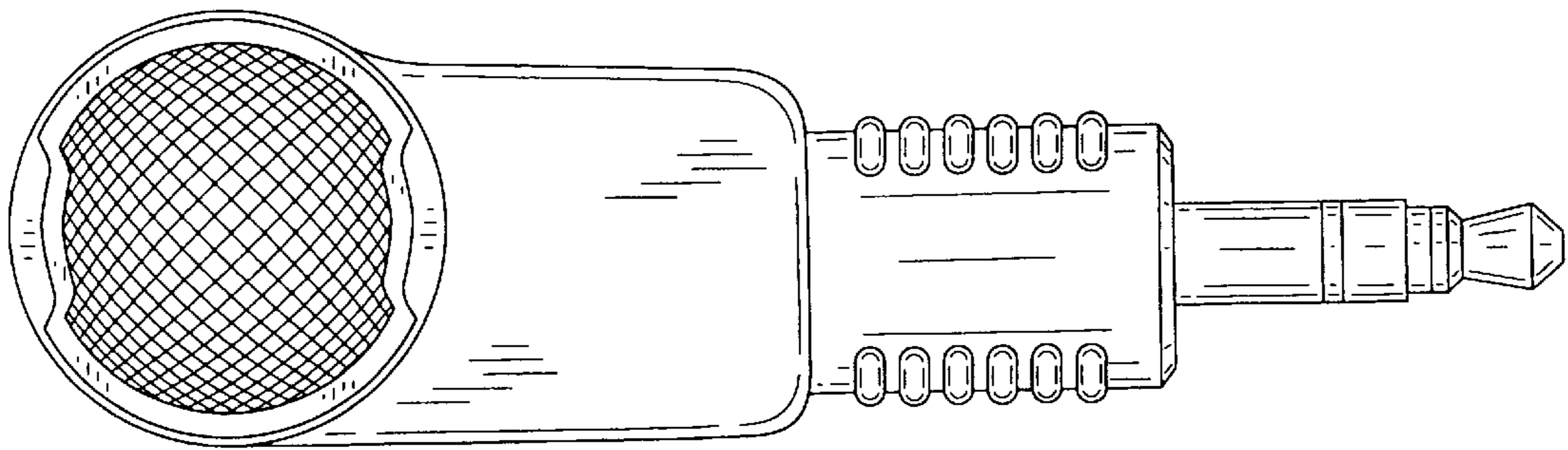

FIG. 3

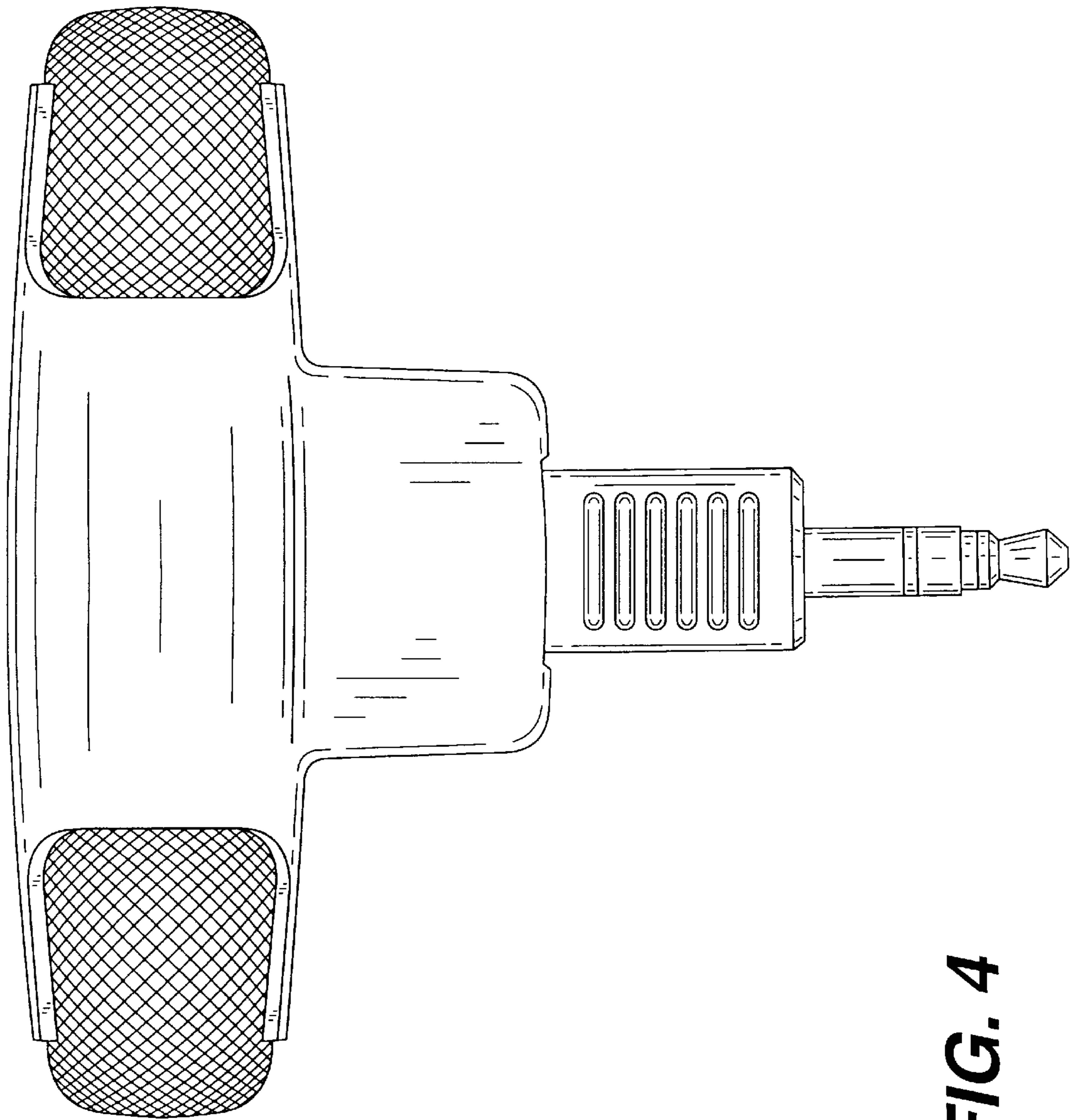

FIG. 4

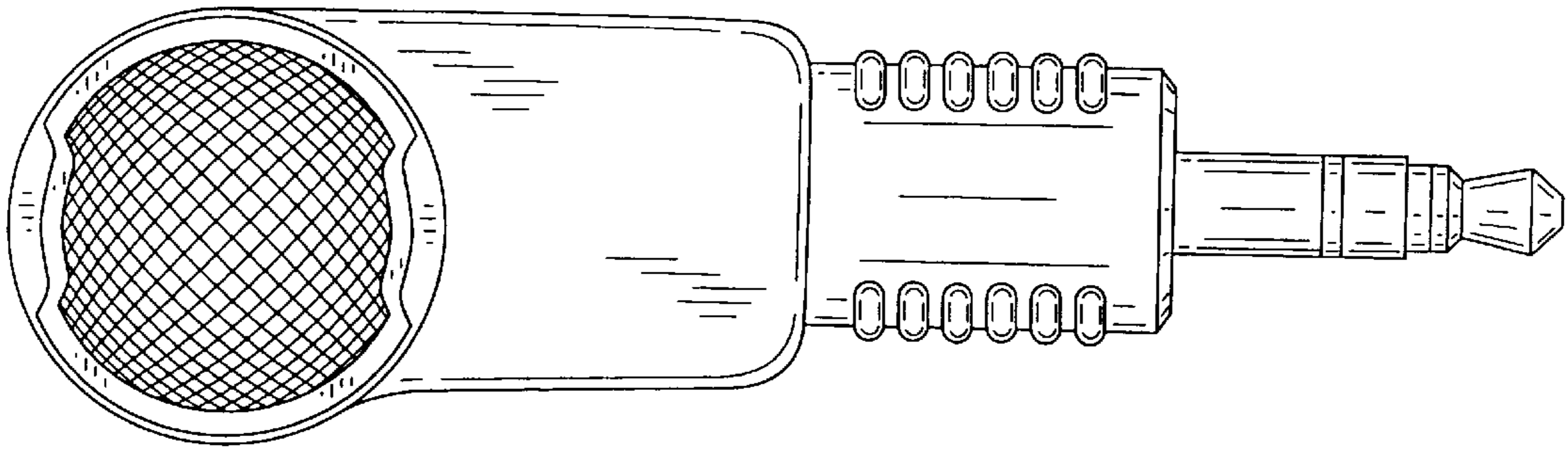

FIG. 5

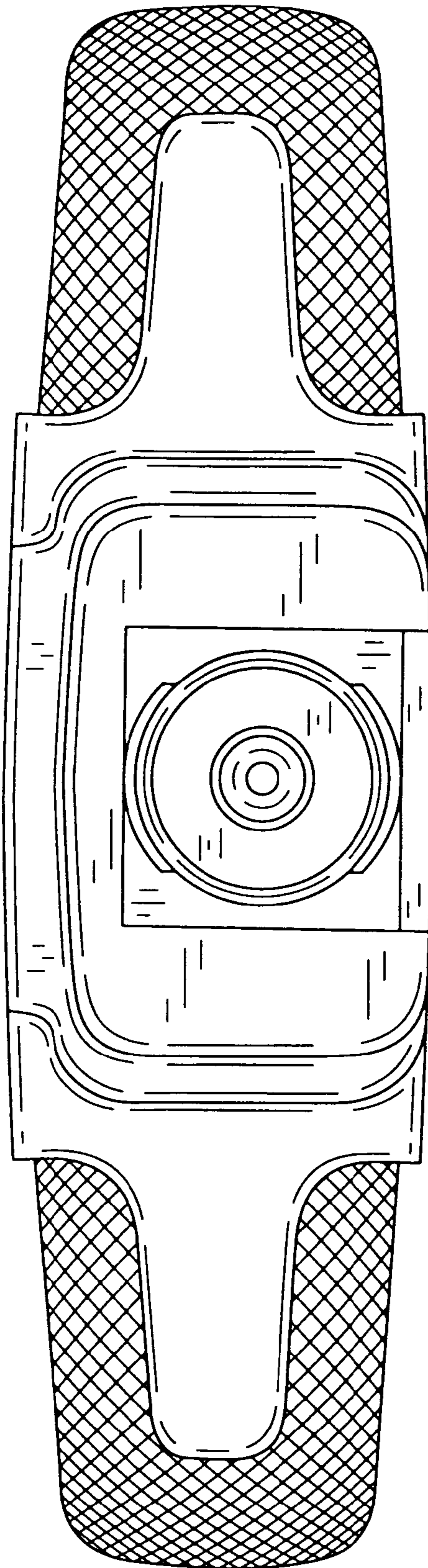

FIG. 6

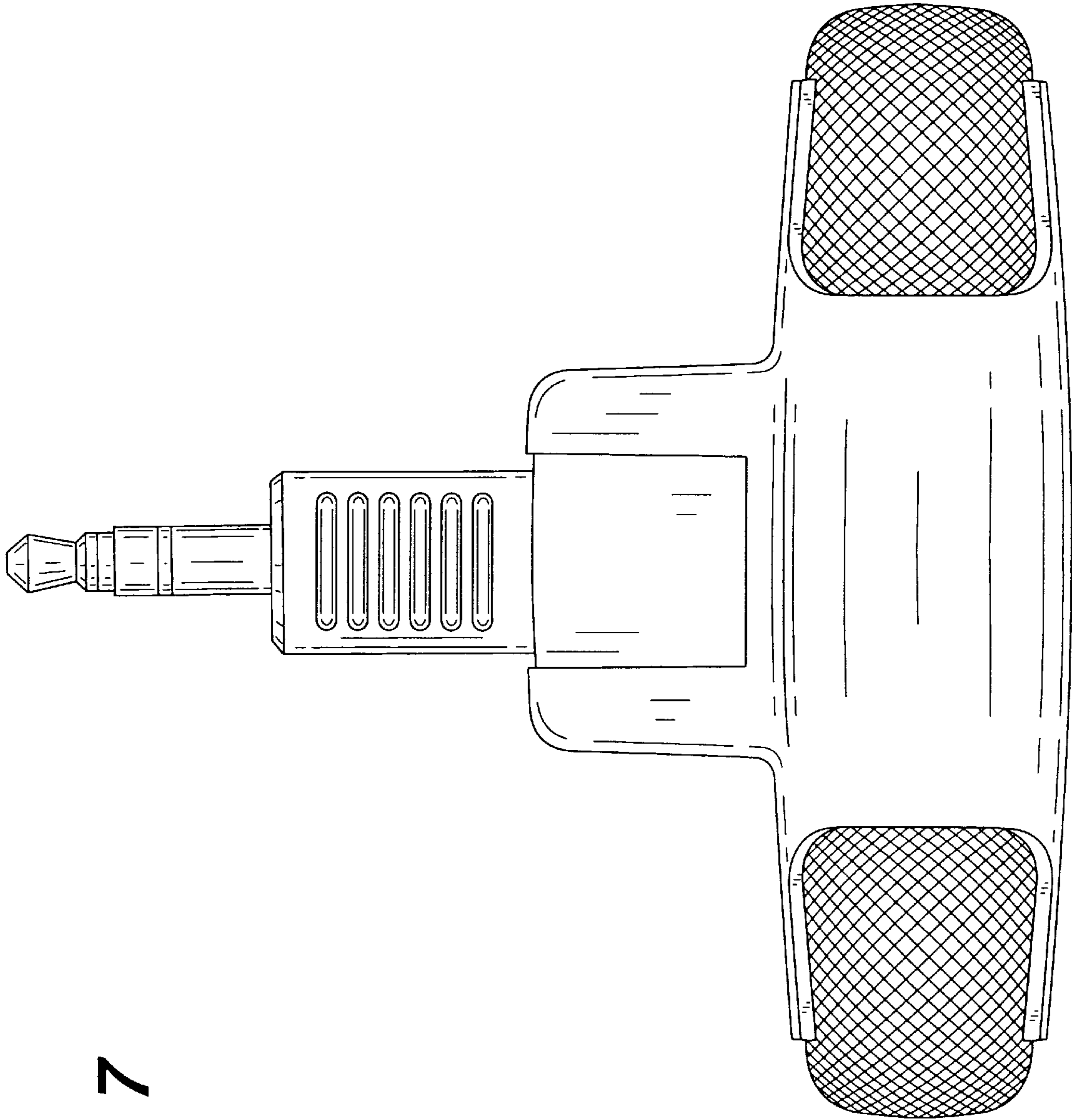

FIG. 7

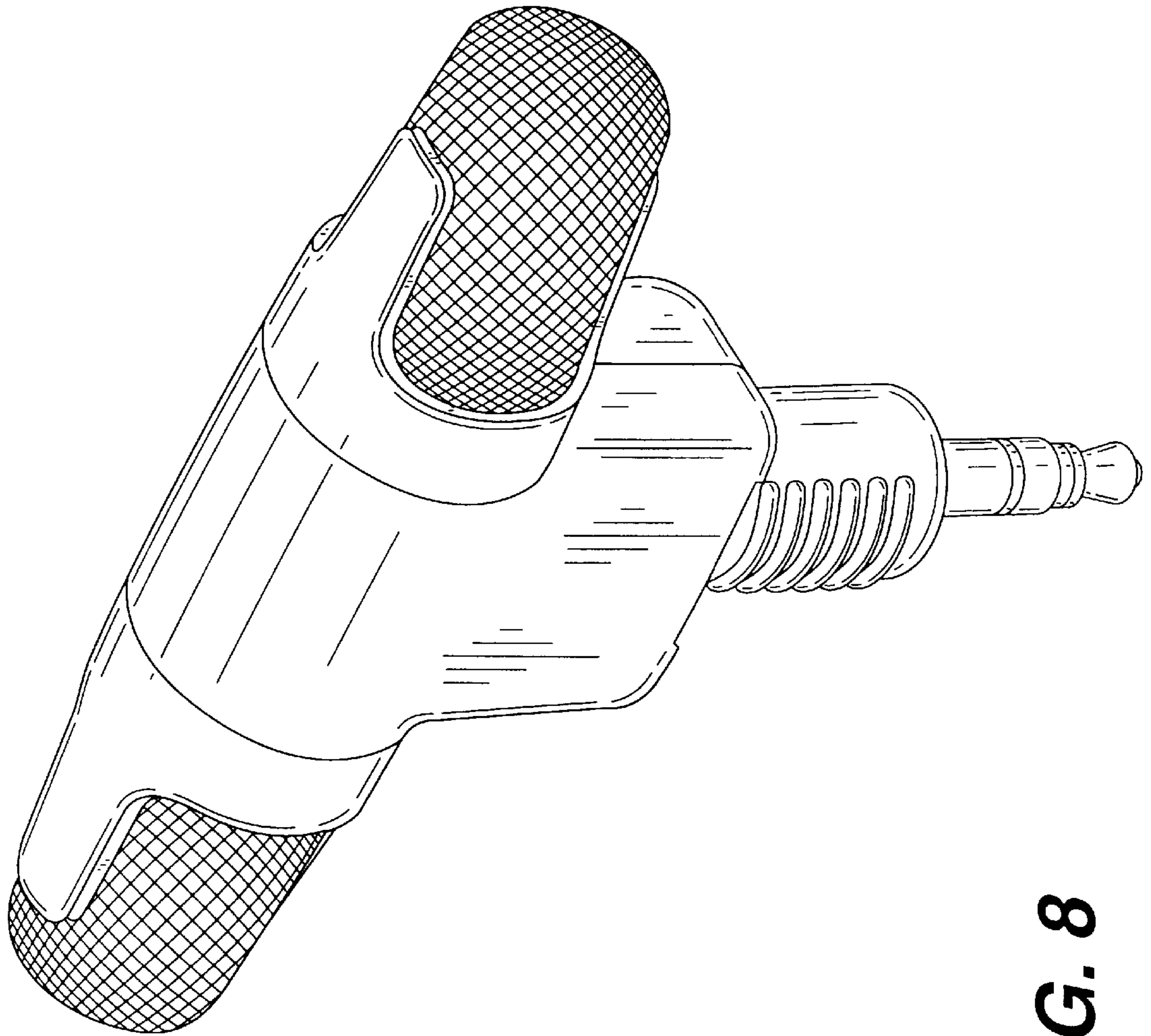

FIG. 8

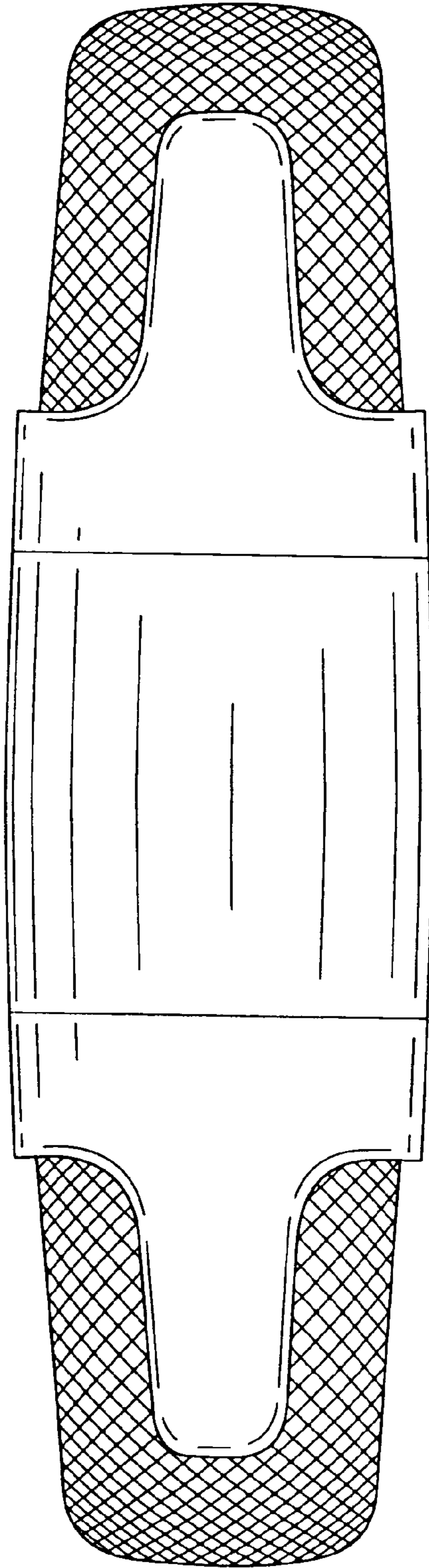

FIG. 9

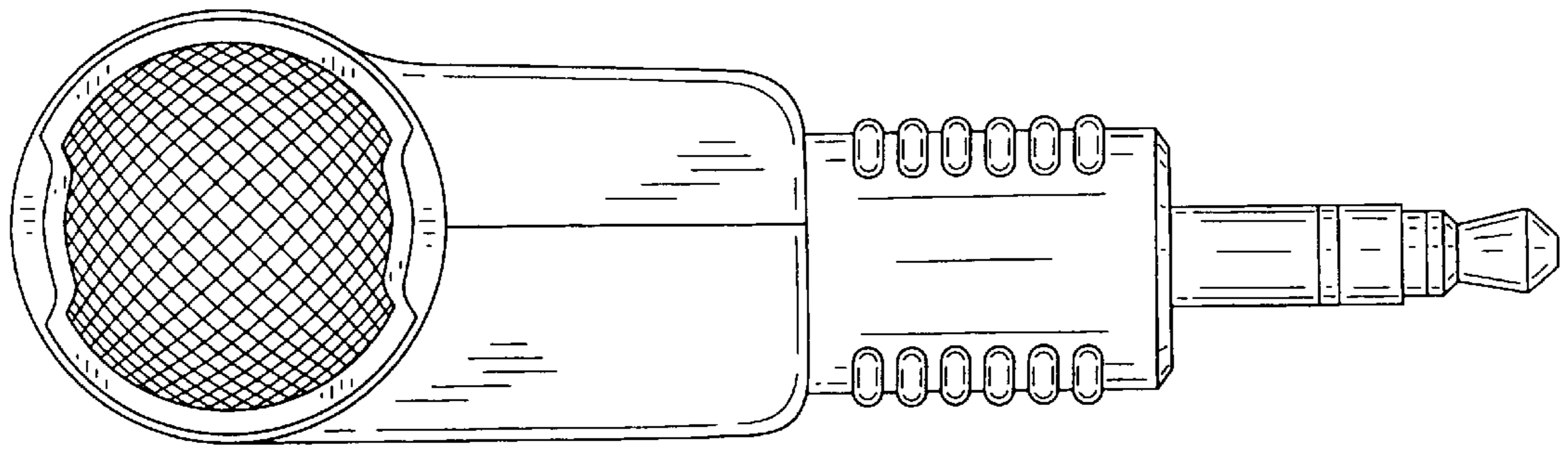

FIG. 10

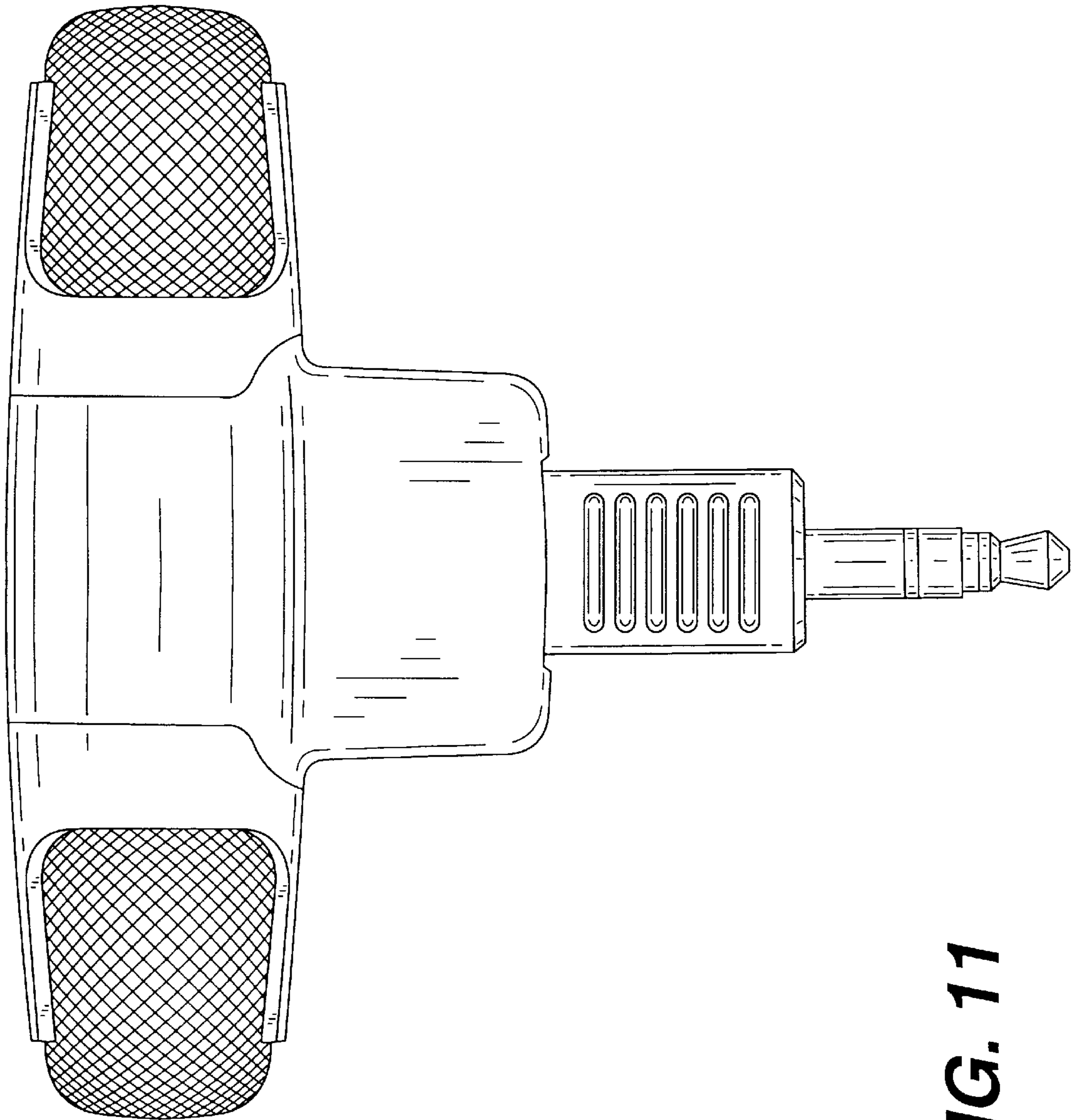

FIG. 11

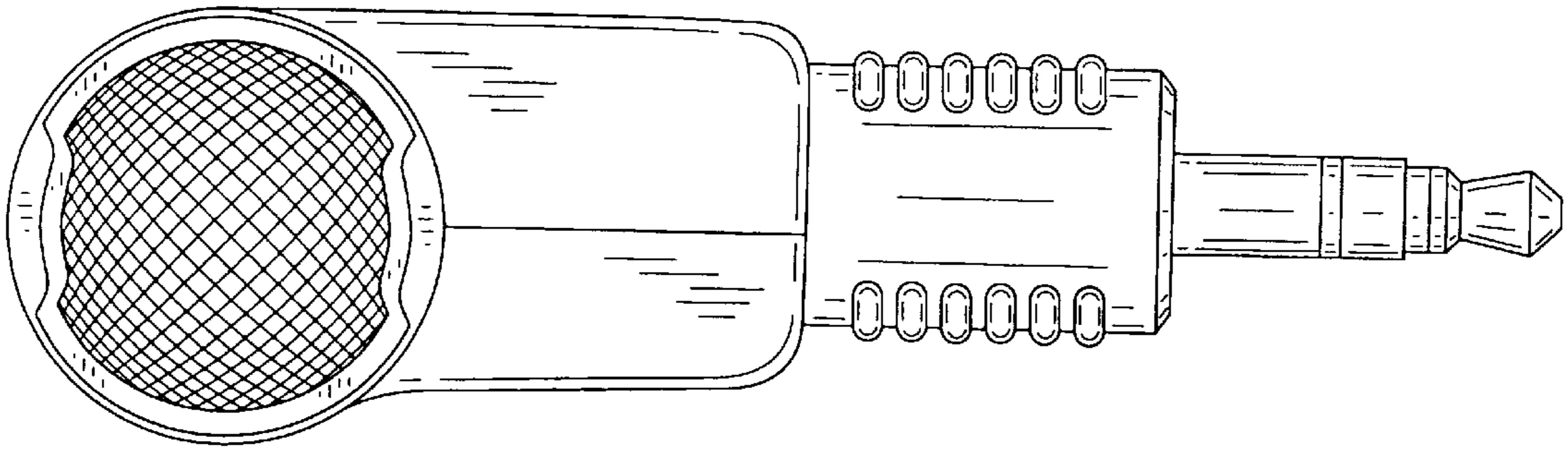

FIG. 12

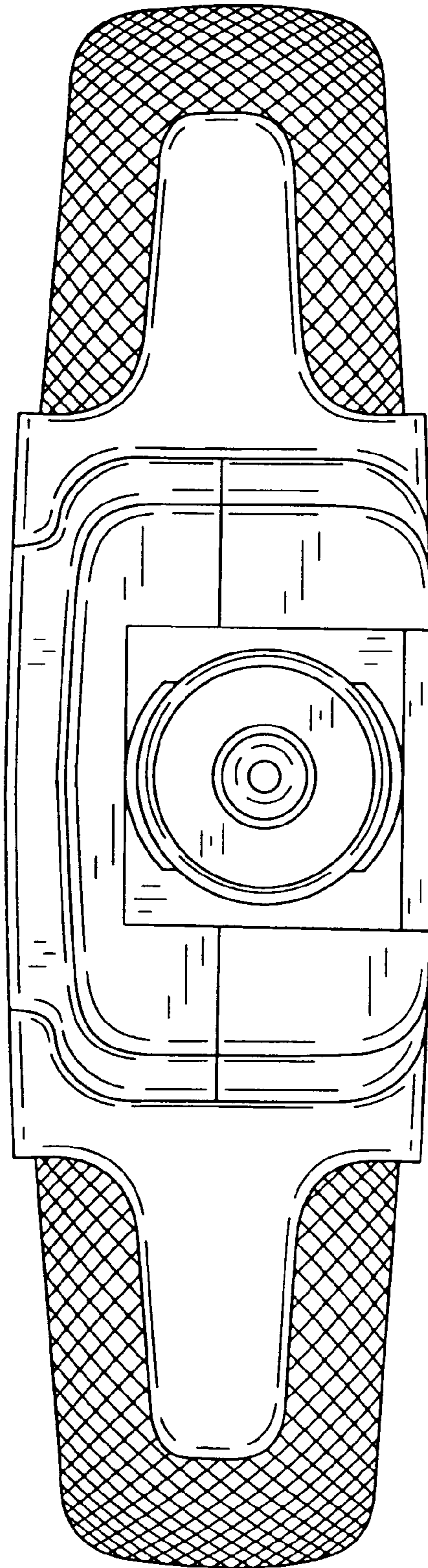

FIG. 13

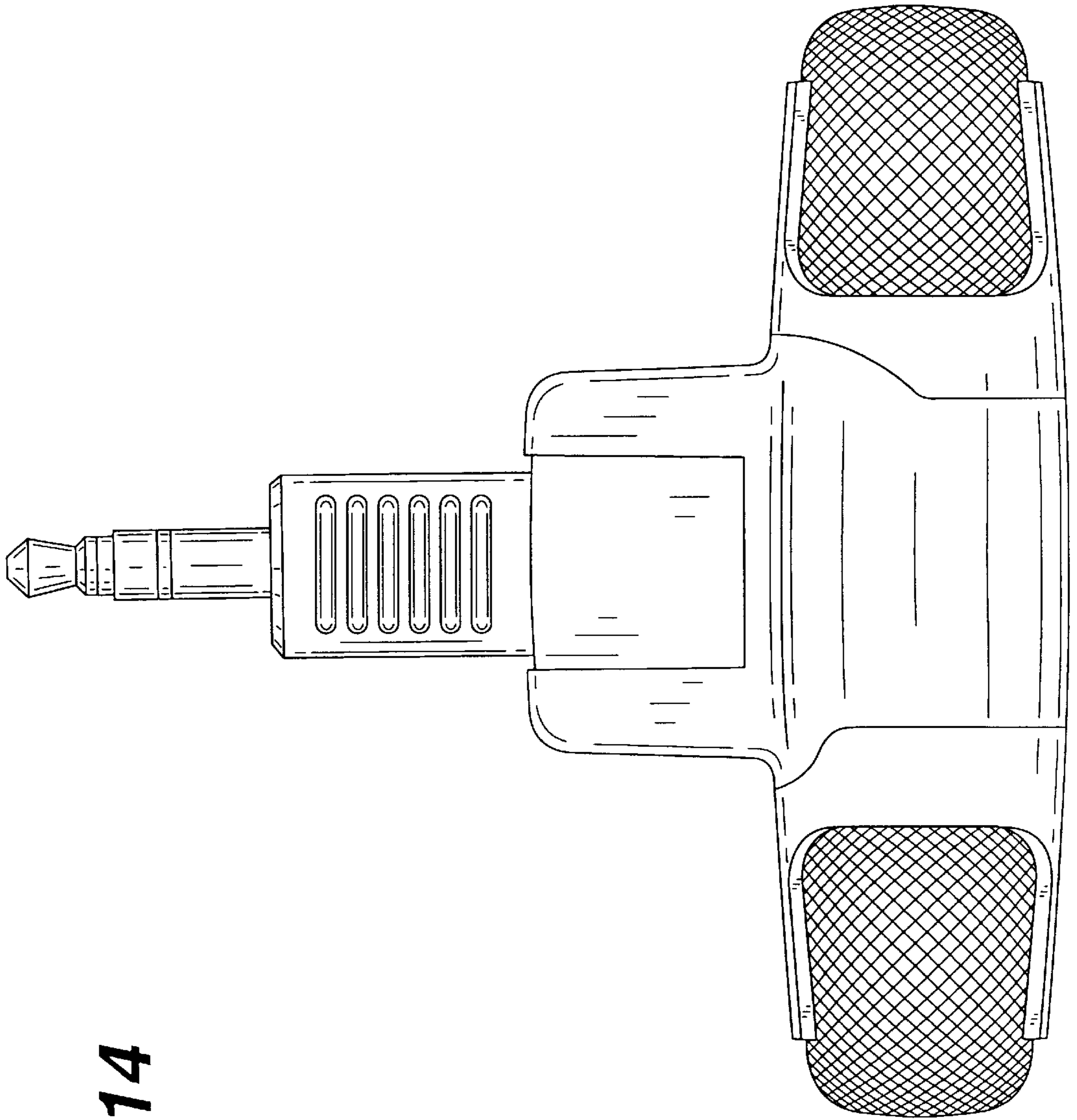

FIG. 14