



US00D418475S

**United States Patent** [19]  
**Milde, Jr.**

[11] **Patent Number: Des. 418,475**  
[45] **Date of Patent: \*\* Jan. 4, 2000**

[54] **PERSONAL AIR TRANSPORT**  
[76] Inventor: **Karl F. Milde, Jr.**, 752 Union Valley Rd., Mahopac, N.Y. 10541  
[\*\*] Term: **14 Years**  
[21] Appl. No.: **29/103,093**  
[22] Filed: **Apr. 8, 1999**

4,807,830 2/1989 Horton ..... 244/12.2  
5,152,478 10/1992 Cycon et al. .... 244/12.2  
5,653,404 8/1997 Ploshkin ..... 244/12.2

*Primary Examiner*—Kay H. Chin

[57] **CLAIM**

The ornamental design for a personal air transport, as shown and described.

**Related U.S. Application Data**

[63] Continuation-in-part of application No. 09/247,163, Feb. 9, 1999.  
[51] **LOC (7) Cl.** ..... **12-07**  
[52] **U.S. Cl.** ..... **D12/325; D12/320**  
[58] **Field of Search** ..... D12/319, 325, D12/320, 326; 244/12.2, 23 C, 17.11, 39

**DESCRIPTION**

FIG. 1 is a top perspective view of a personal air transport showing my new design, the broken lines are for illustrative purposes only and form no part of the claimed design; FIG. 2 is a side elevational view thereof, the opposite side view being a mirror image of that shown; FIG. 3 is a top plan view thereof; FIG. 4 is a bottom plan view thereof; and, FIG. 5 is a front elevational view thereof.

[56] **References Cited**

**U.S. PATENT DOCUMENTS**

D. 312,067 11/1990 Walling ..... D12/325

**1 Claim, 4 Drawing Sheets**

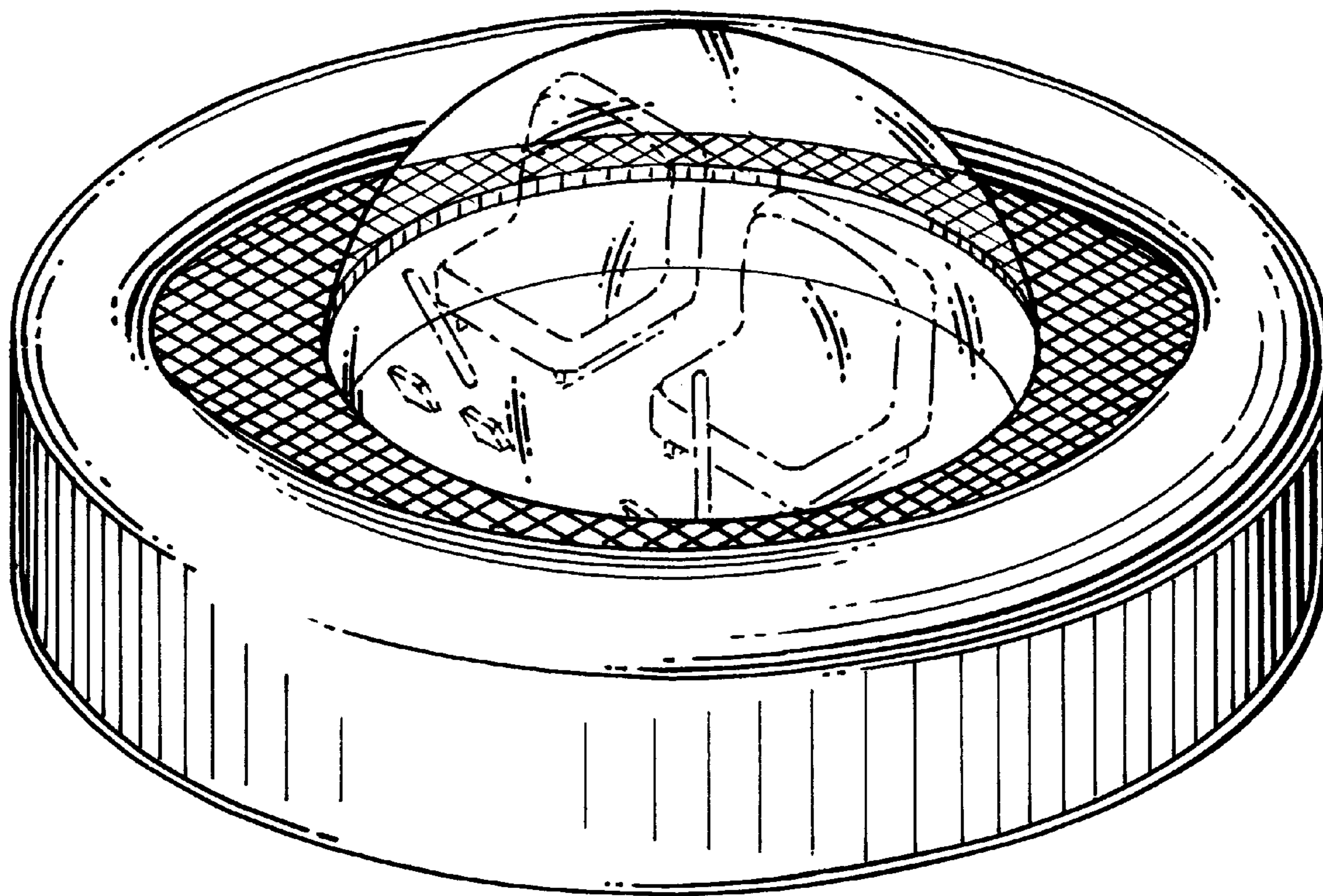

FIG.1

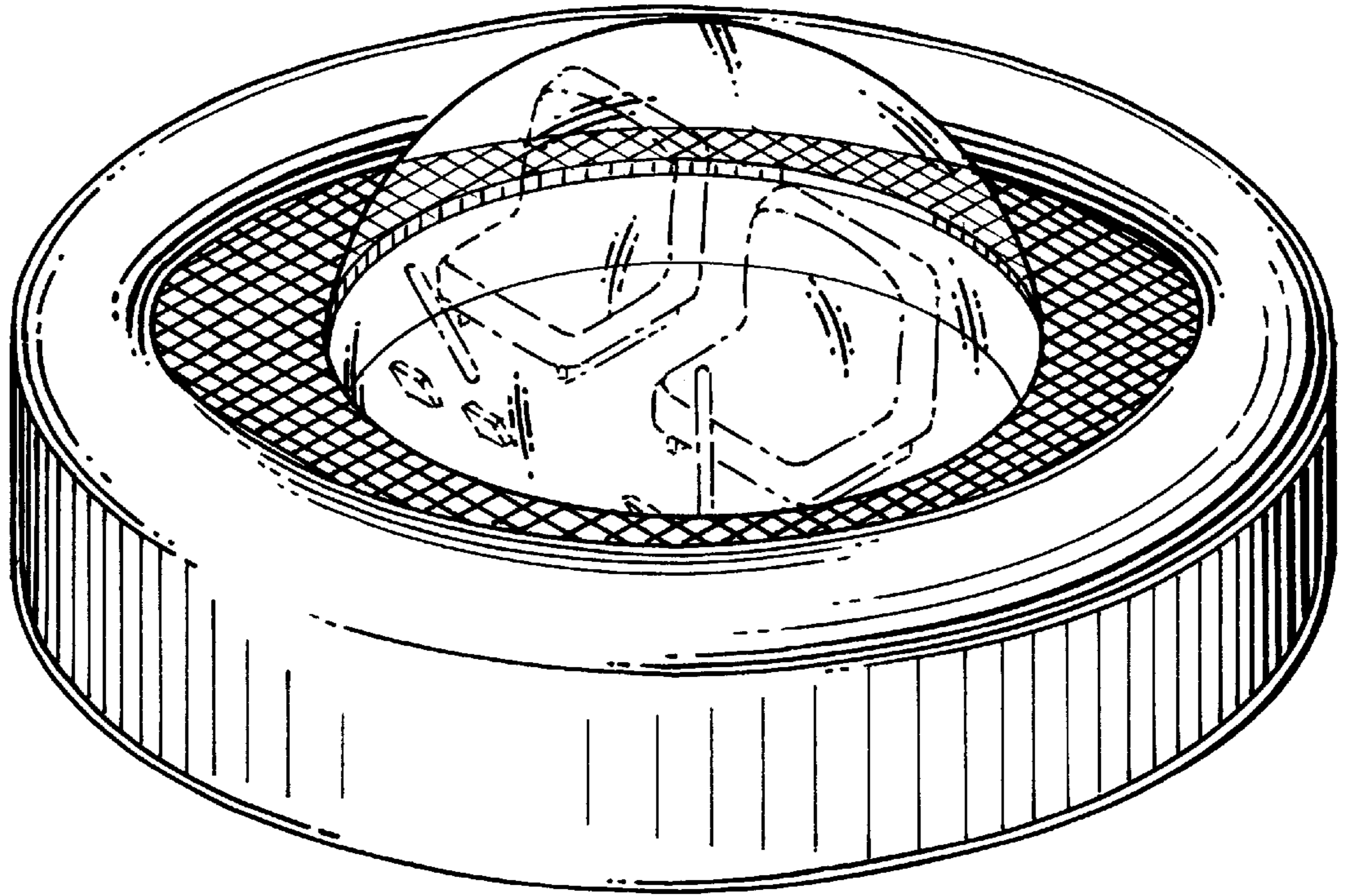
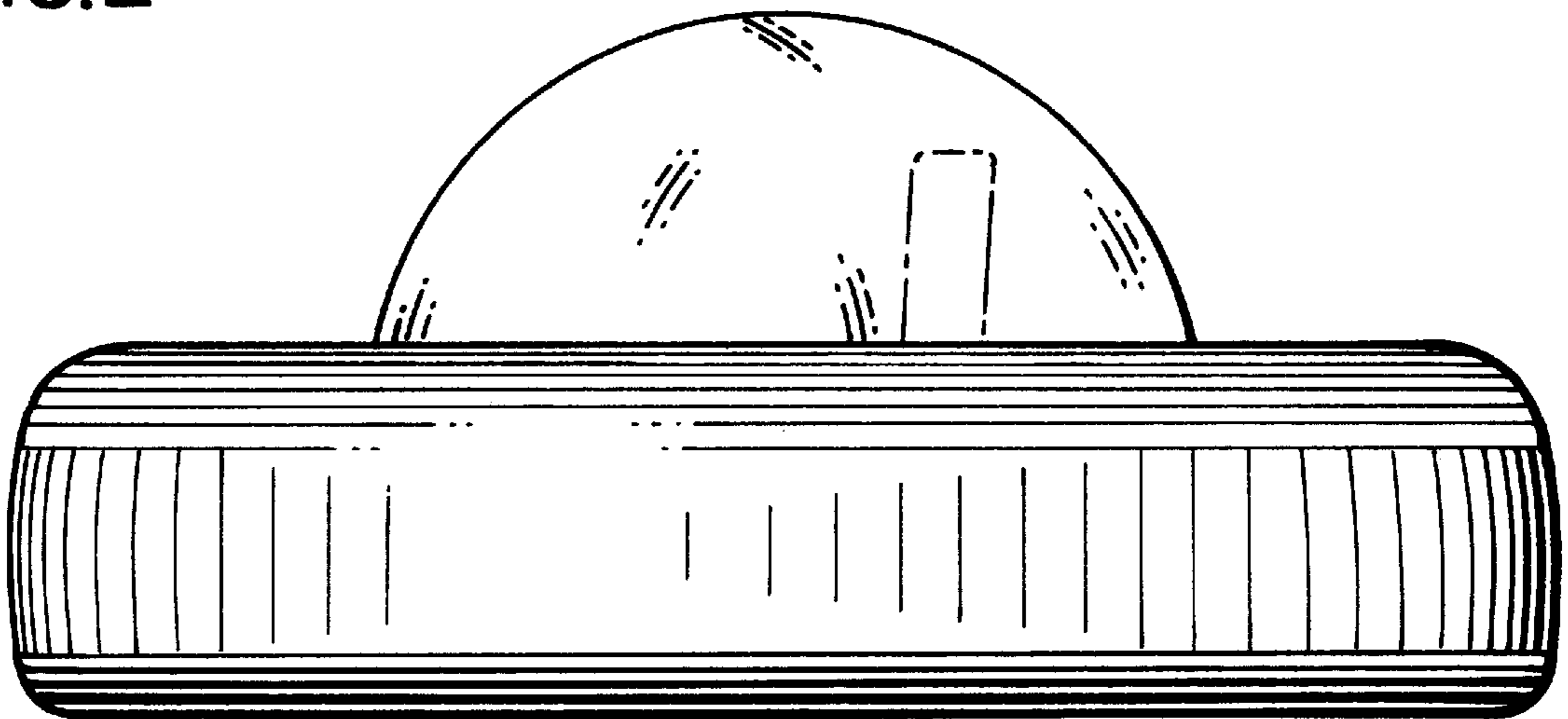

FIG.2





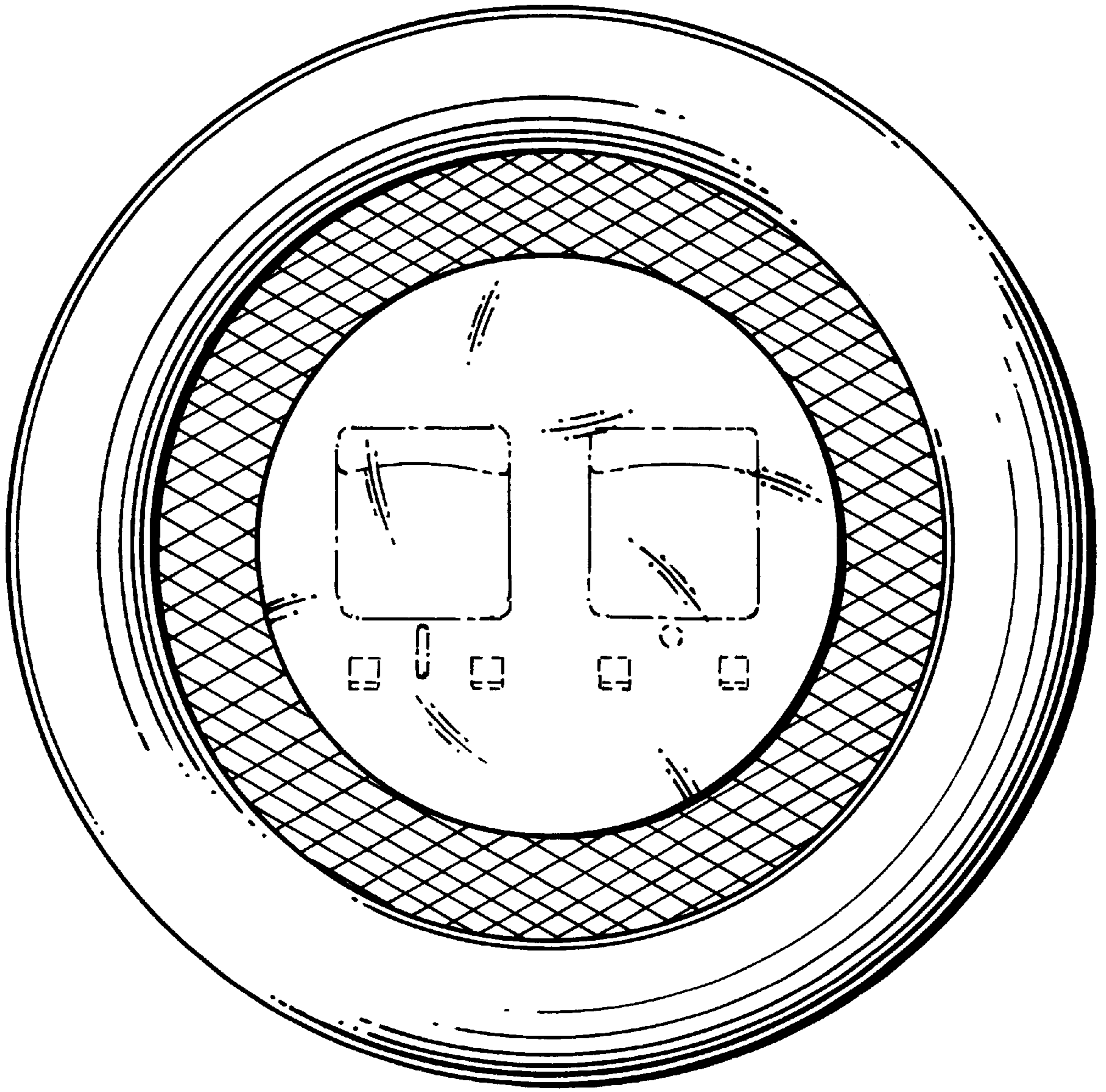

FIG.3

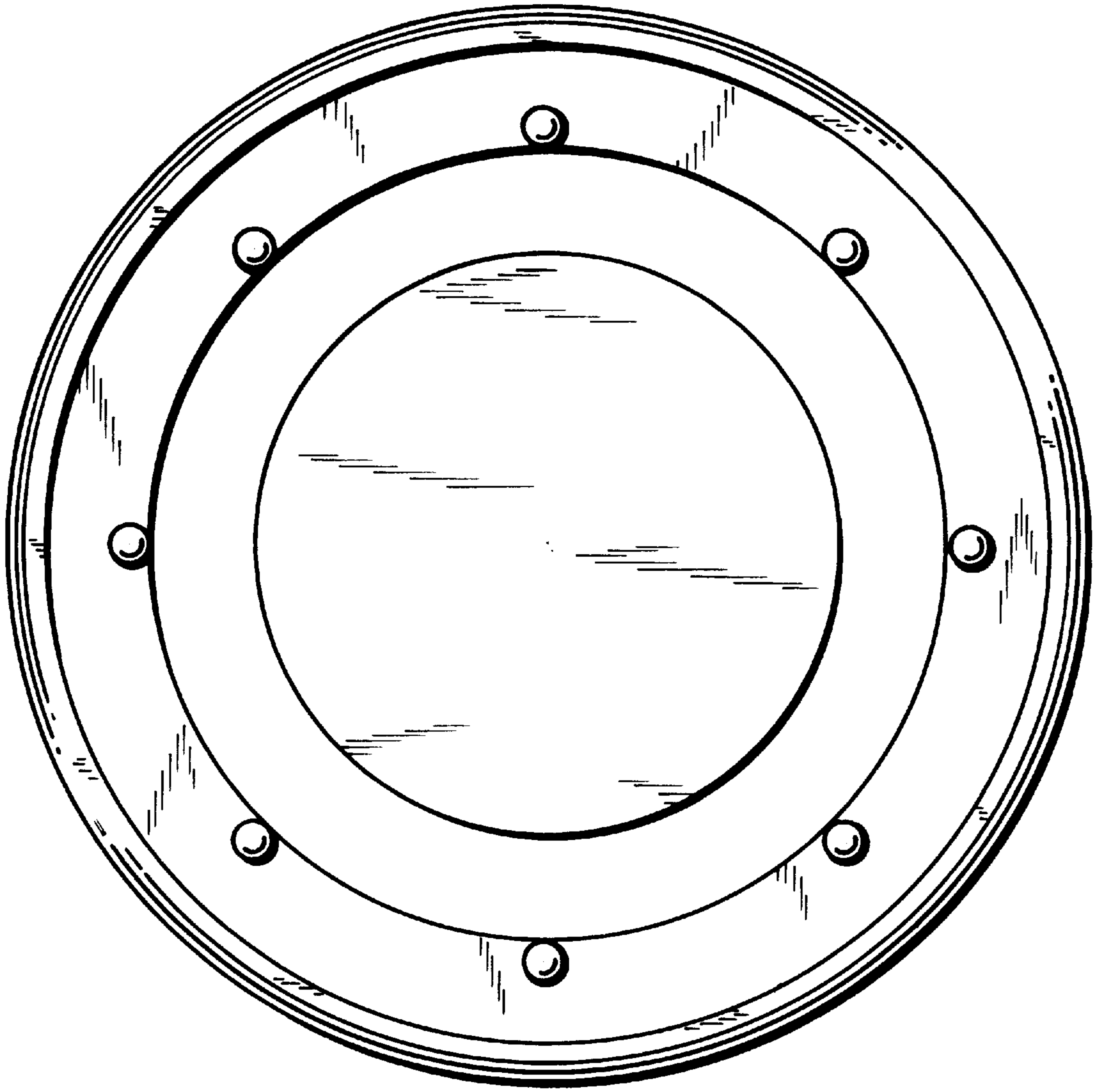

FIG.4

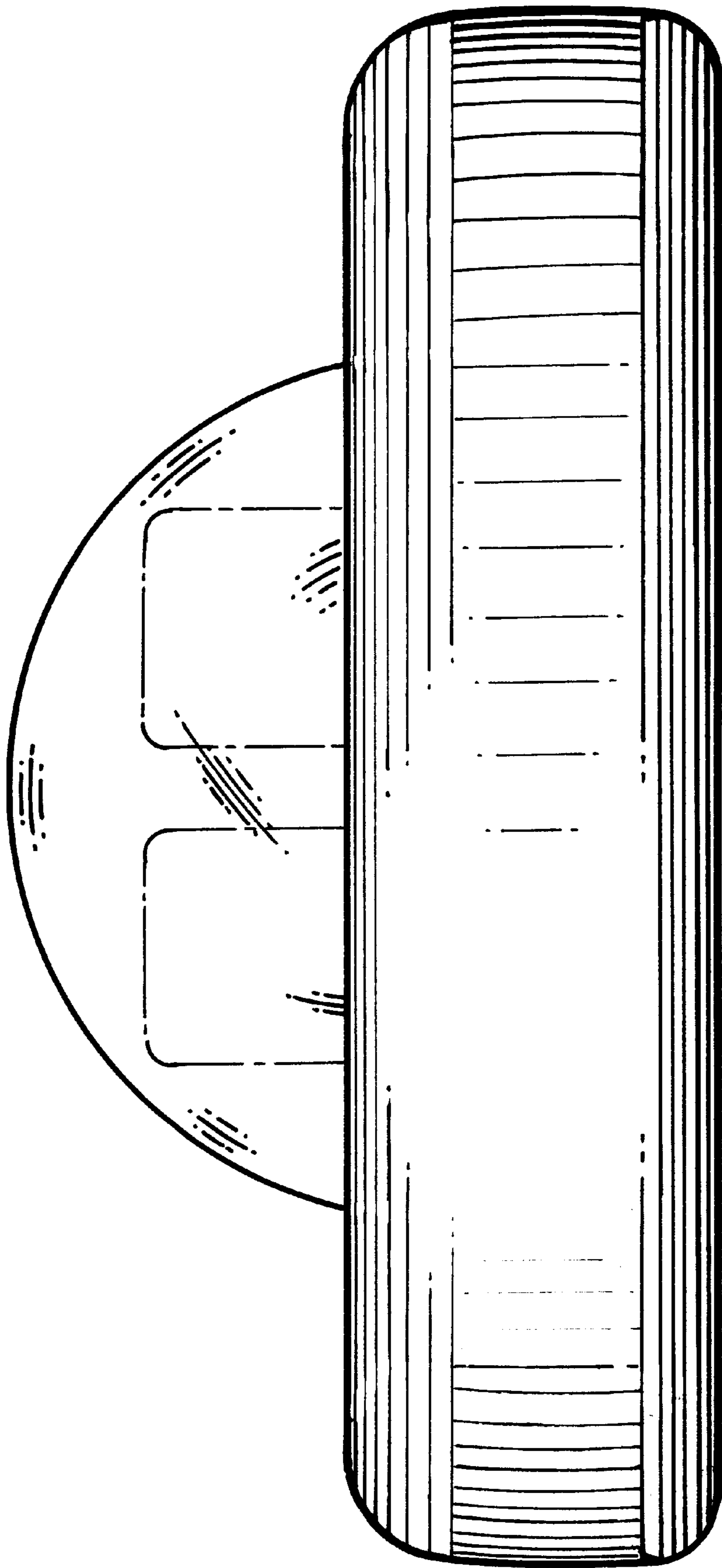

FIG.5