



US00D418394S

# United States Patent [19] King

[11] **Patent Number: Des. 418,394**  
[45] **Date of Patent: \*\* Jan. 4, 2000**

[54] **MOUNTING RAIL**

[75] Inventor: **Robert H. King**, Martin, Tenn.

[73] Assignee: **Tennessee Truck Works, L.L.C.**,  
Dresden, Tenn.

[\*\*] Term: **14 Years**

[21] Appl. No.: **29/104,818**

[22] Filed: **May 10, 1999**

[51] **LOC (7) Cl.** ..... **08-05**

[52] **U.S. Cl.** ..... **D8/354; D25/124**

[58] **Field of Search** ..... D8/349, 354; D25/119,  
D25/121, 123, 124; 248/300, 200; 52/651.07,  
726.02, 731.1

[56] **References Cited**

**U.S. PATENT DOCUMENTS**

D. 366,322 1/1996 Palermo ..... D25/124  
D. 376,855 12/1996 Leung ..... D25/124

**OTHER PUBLICATIONS**

Ultrex catalog, p. 5, limit switch guide, located at bottom left of page, Jan. 1975.

*Primary Examiner*—Holly Baynham  
*Attorney, Agent, or Firm*—Walker, McKenzie & Walker P.C.

[57] **CLAIM**

The ornamental design for a mounting rail, as shown and described.

**DESCRIPTION**

FIG. 1 is a perspective view of a mounting rail, showing my new design.

FIG. 2 is a front end elevation of the mounting rail of FIG. 1, the rear end being a mirror image thereof.

FIG. 3 is a top plan view of the mounting rail of FIG. 1, the bottom being a mirror image thereof; and,

FIG. 4 is a side elevation of the mounting rail of FIG. 1, the opposite side being a mirror image thereof.

Portions of the mounting rail are shown broken away in FIGS. 1, 3 and 4 to indicate indefinite length.

**1 Claim, 2 Drawing Sheets**

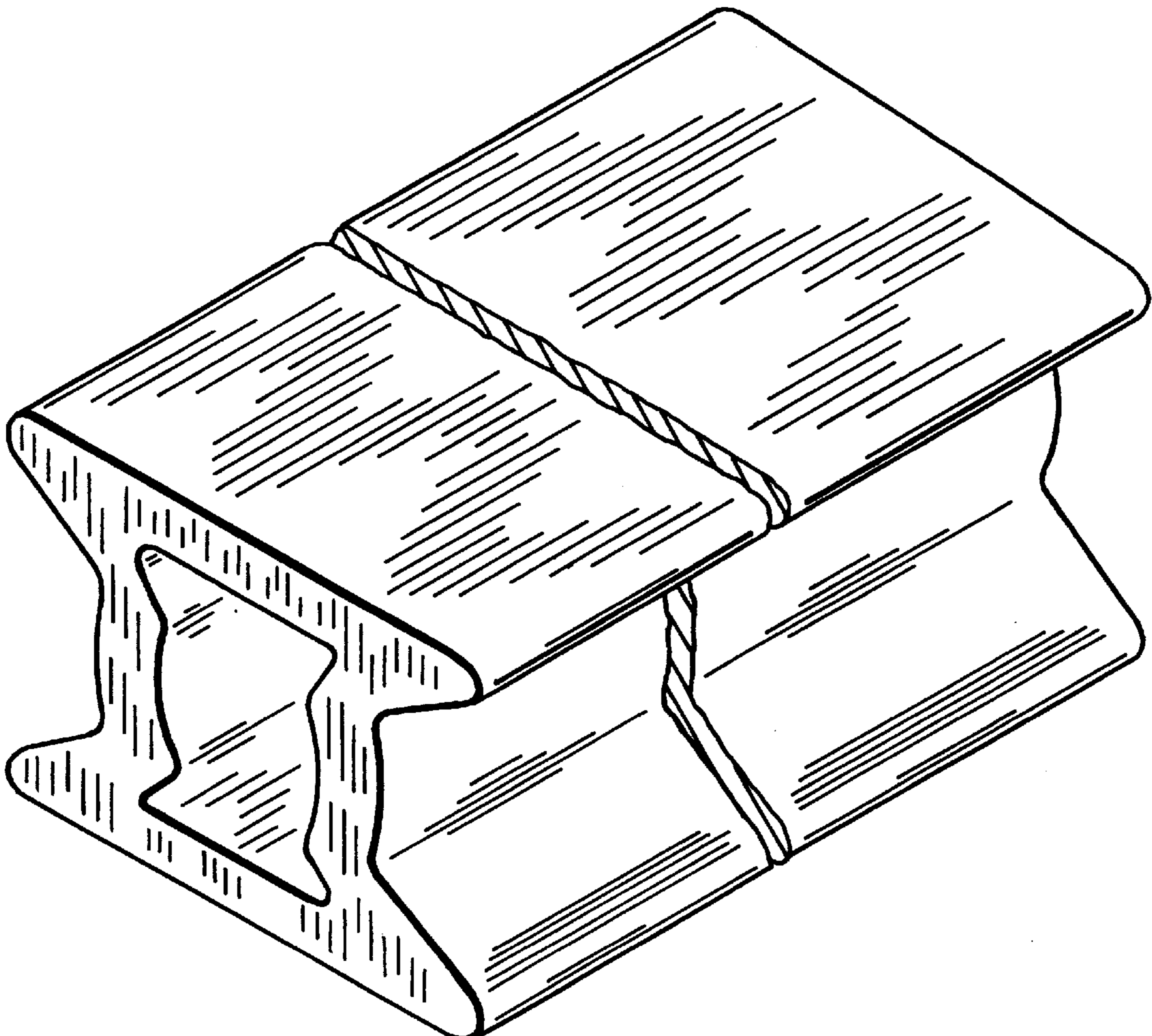

**FIG. 1**

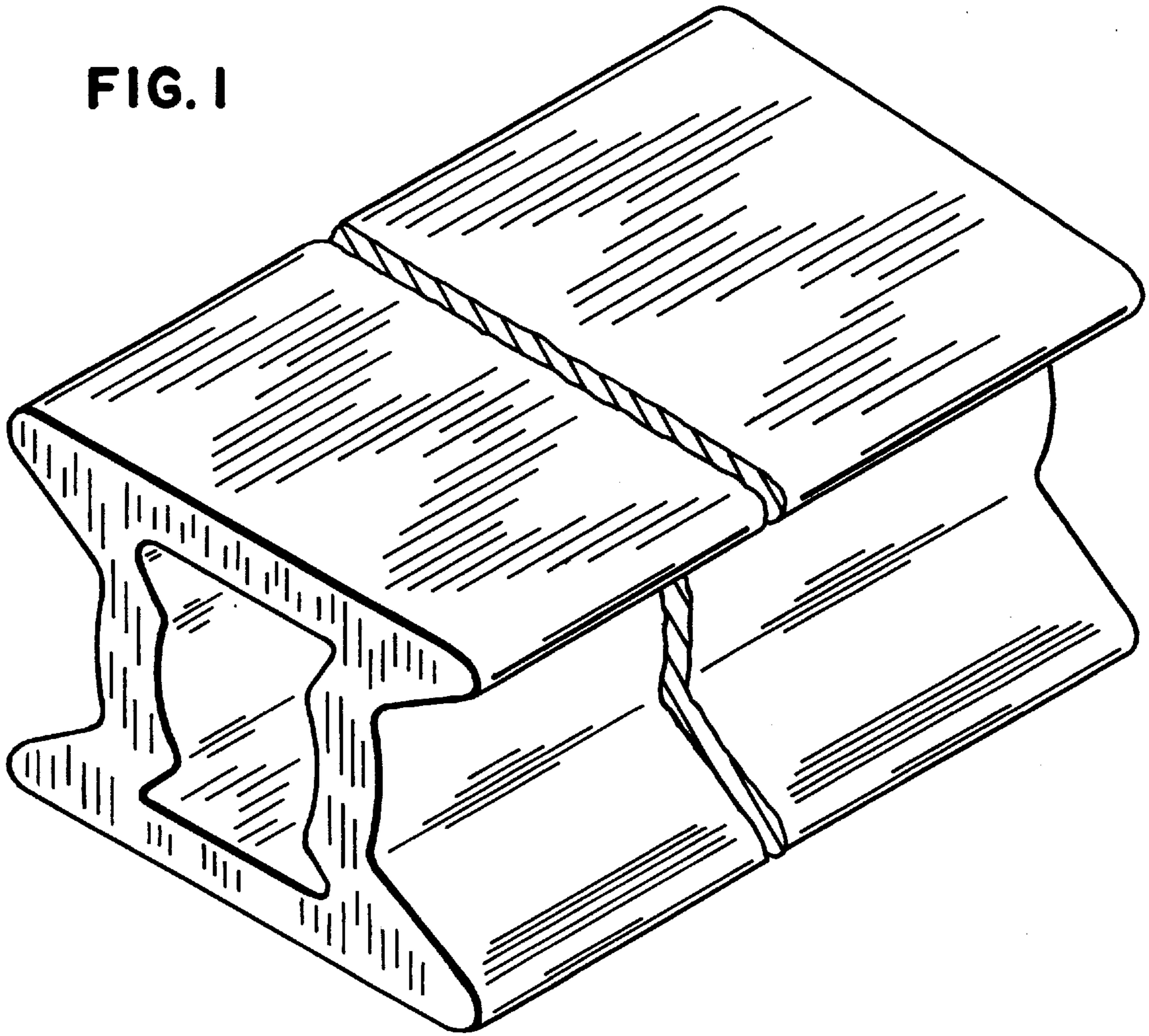

**FIG. 2**

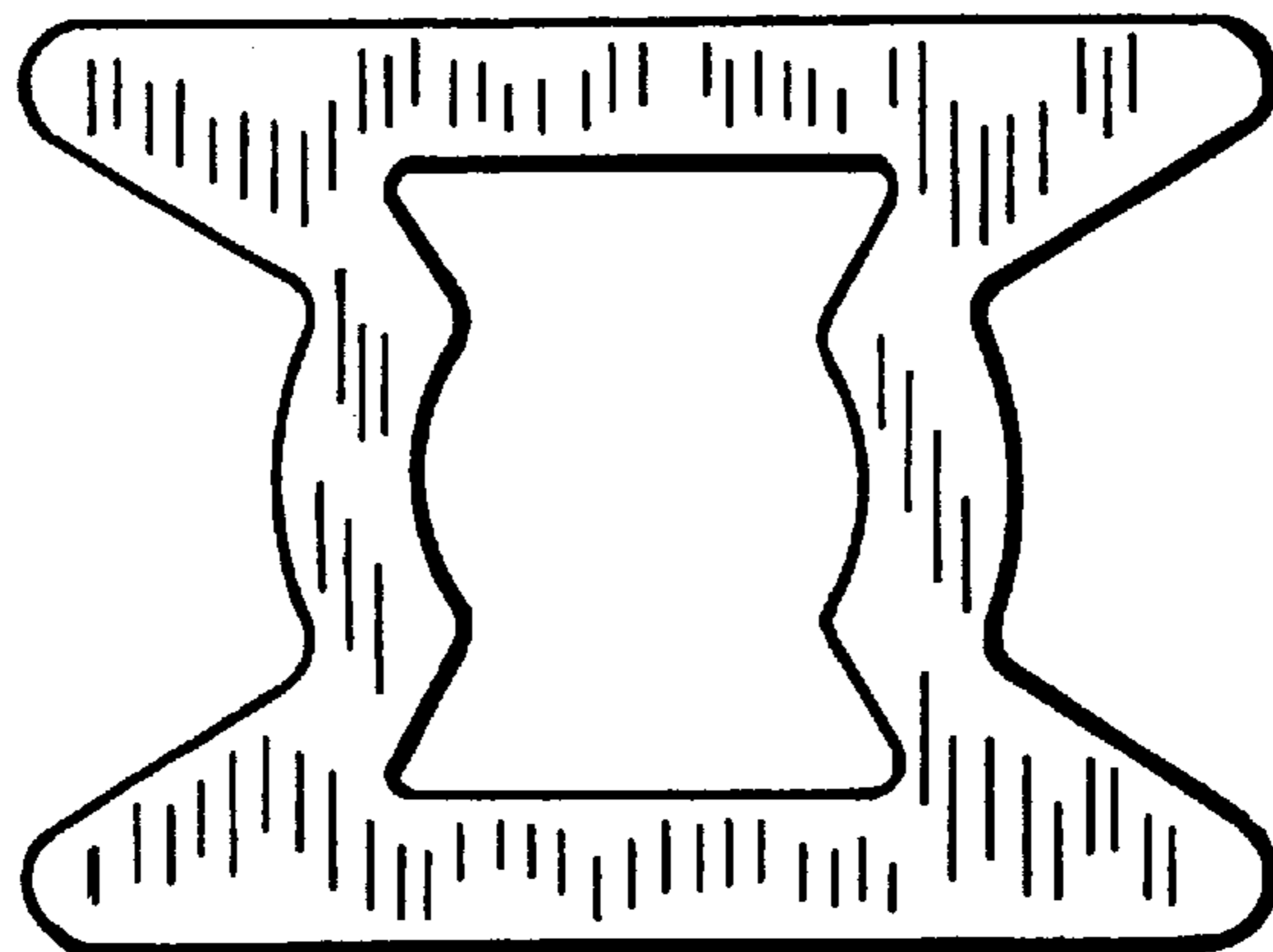

**FIG. 3**

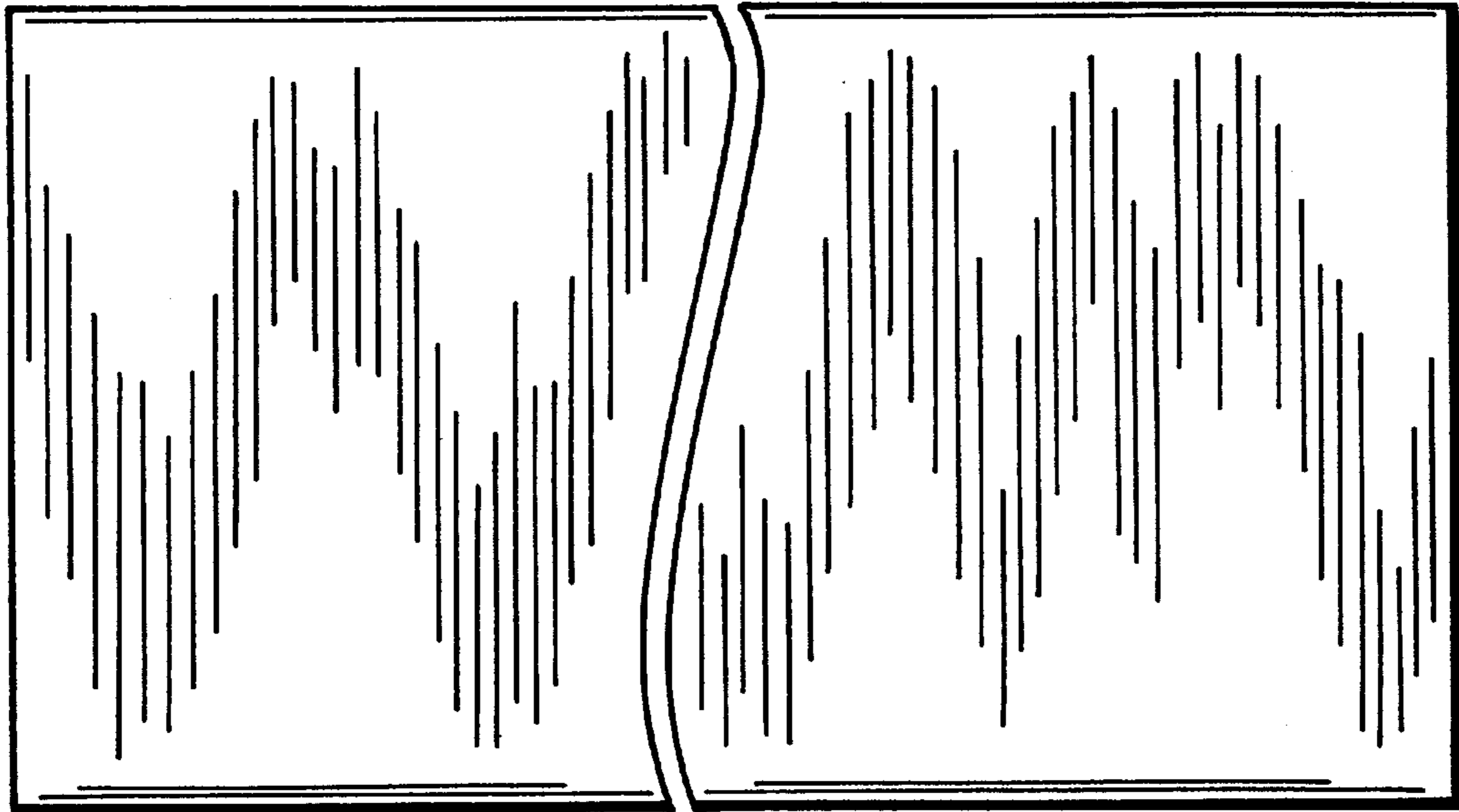

**FIG. 4**

