



US00D418105S

# United States Patent [19] Margaritoff

[11] **Patent Number: Des. 418,105**

[45] **Date of Patent: \*\* Dec. 28, 1999**

[54] **SIX SEATER TWIN ENGINE AIRCRAFT**

5,480,107 1/1996 Bacon ..... 244/55

[76] Inventor: **Michael Margaritoff**, 400 Clematis St.,  
Suite 207, West Palm Beach, Fla. 33401

*Primary Examiner*—Kay H. Chin  
*Attorney, Agent, or Firm*—McHale & Slavin

[\*\*] Term: **14 Years**

[57] **CLAIM**

[21] Appl. No.: **29/099,775**

The ornamental design for six seater twin engine aircraft, as shown and described.

[22] Filed: **Jan. 26, 1999**

### DESCRIPTION

[51] **LOC (6) Cl.** ..... **12-07**

[52] **U.S. Cl.** ..... **D12/319; D12/342; D12/343**

[58] **Field of Search** ..... **D12/319-345;**  
244/48, 45 R, 45 A, 55, 15, 91, 199, 13

FIG. 1 is a right-side view of a six seater twin engine aircraft of the instant invention;

FIG. 2 is a left-side view thereof;

FIG. 3 is a top view thereof;

FIG. 4 is a bottom view thereof;

FIG. 5 is a front view thereof;

FIG. 6 is a back view thereof; and,

FIG. 7 is a perspective view thereof.

### [56] **References Cited**

#### U.S. PATENT DOCUMENTS

- |            |        |           |       |         |
|------------|--------|-----------|-------|---------|
| D. 264,838 | 6/1982 | Dornier   | ..... | D12/324 |
| D. 338,245 | 6/1994 | Blum      | ..... | D12/332 |
| 5,280,863  | 1/1994 | Schmittle | ..... | 244/48  |

**1 Claim, 7 Drawing Sheets**

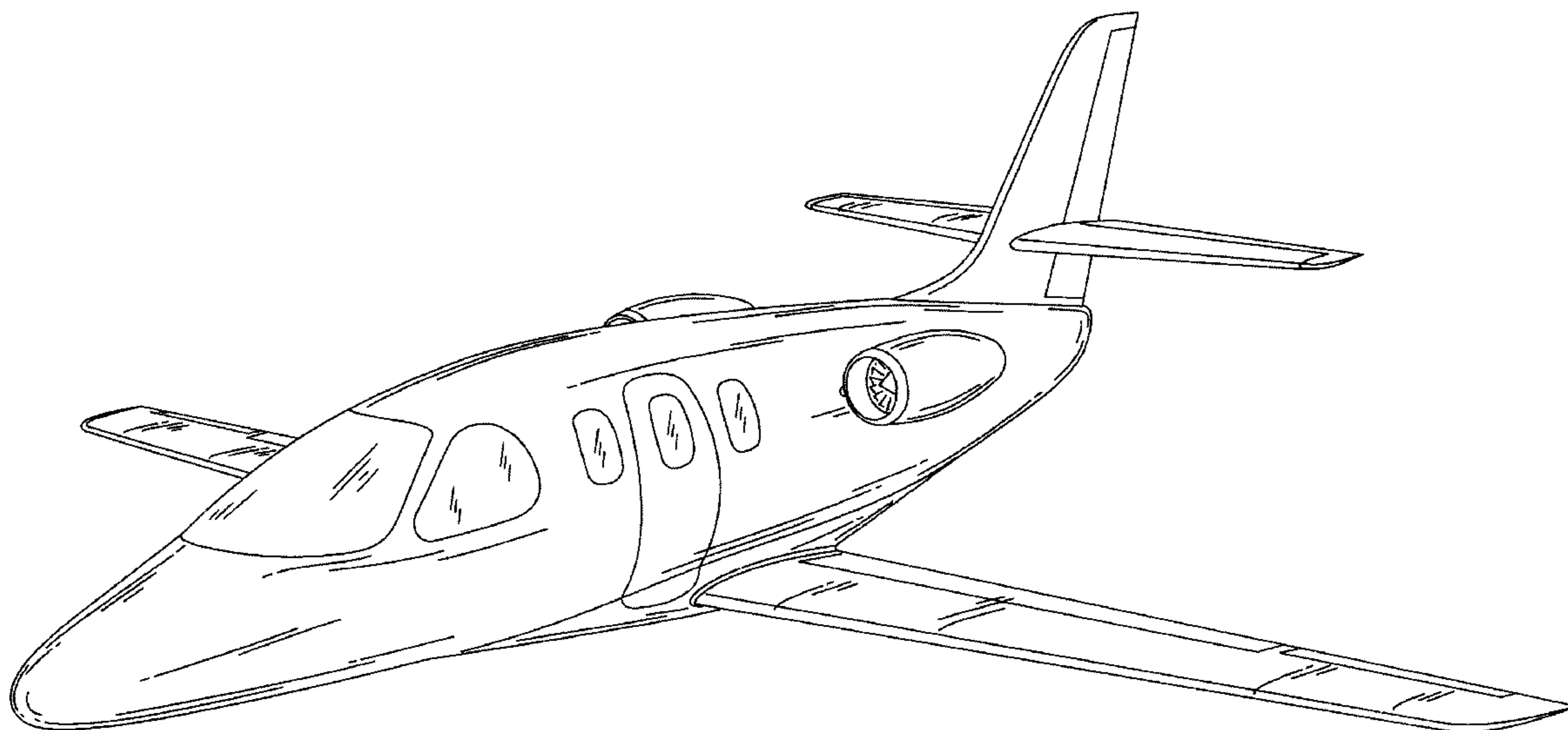

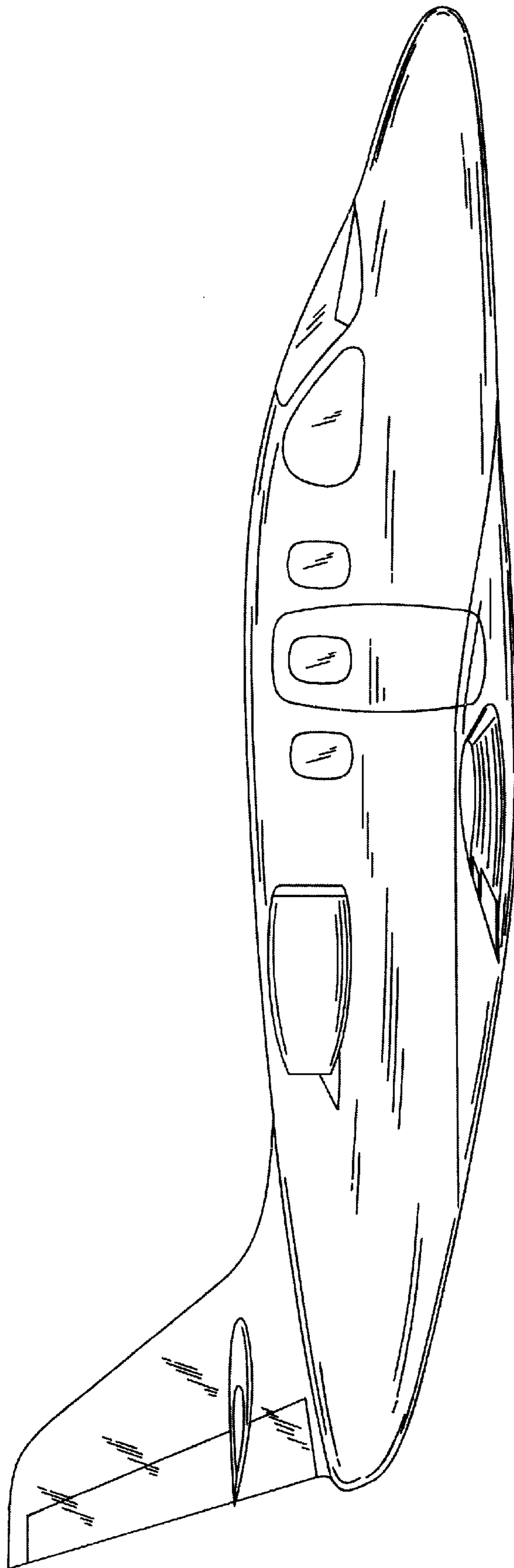

Fig. 1

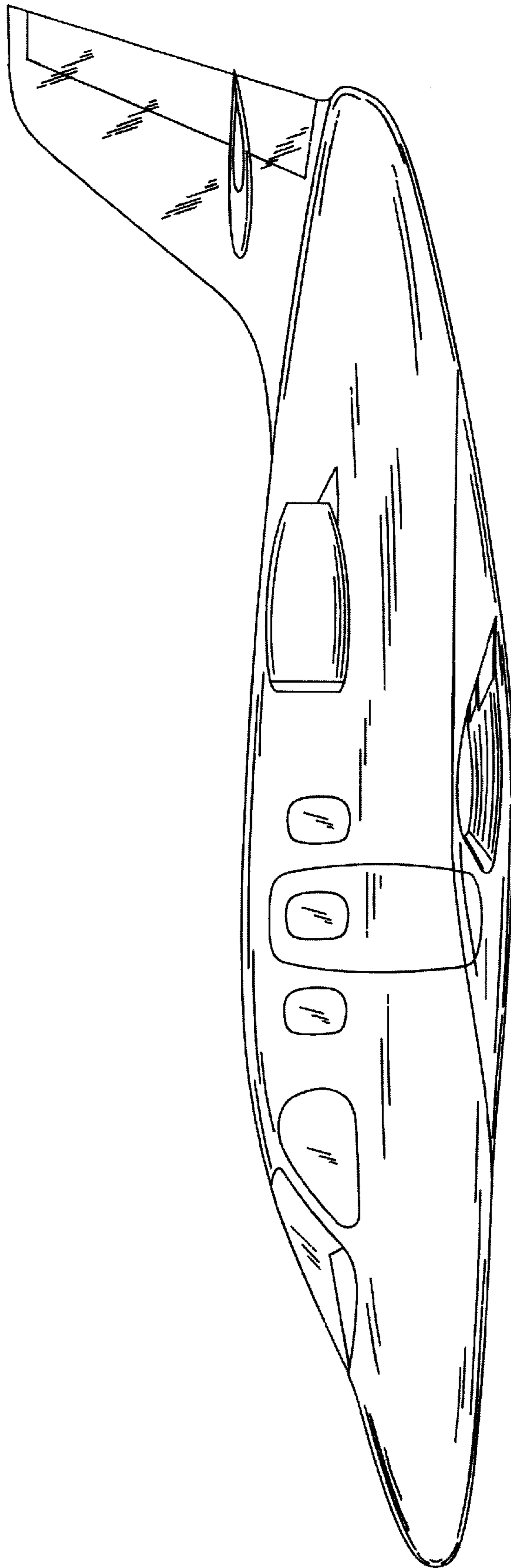

Fig. 2

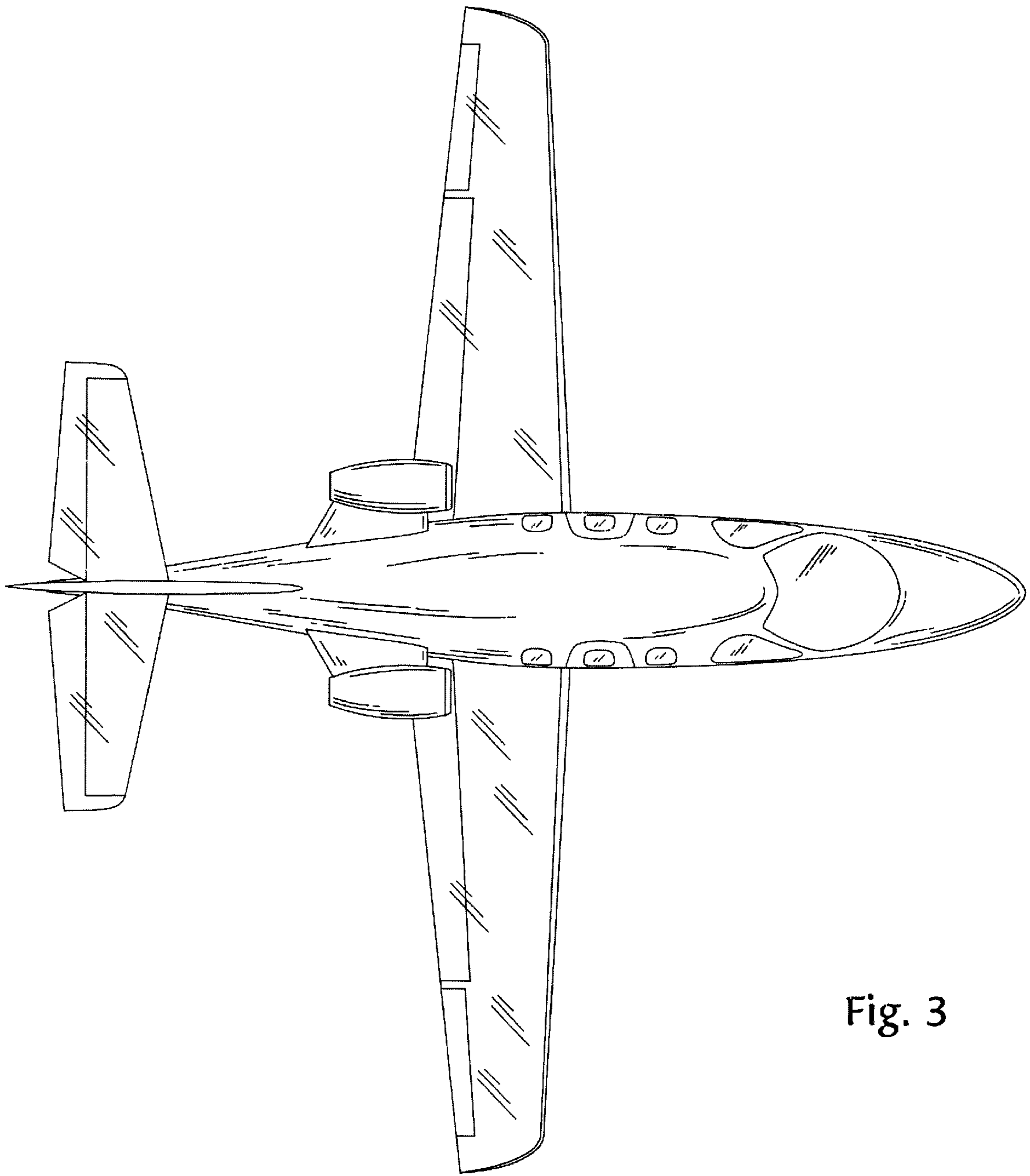

Fig. 3

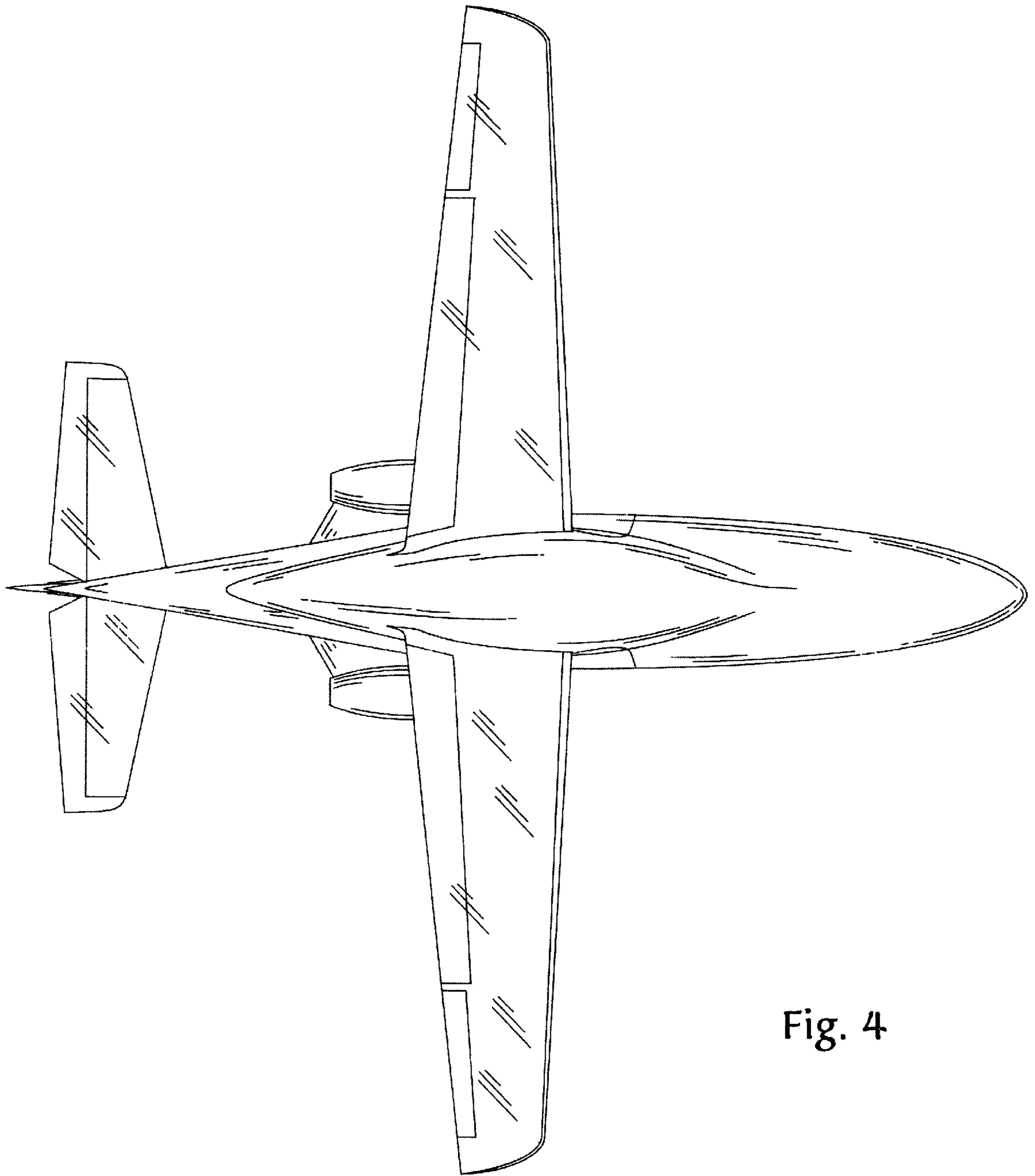

Fig. 4

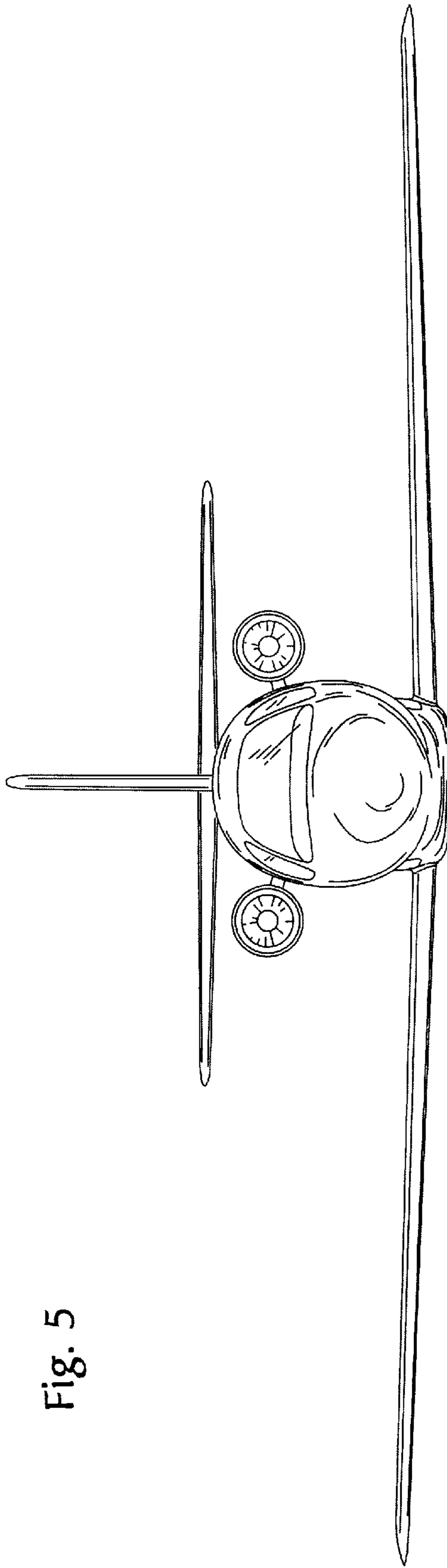

Fig. 5

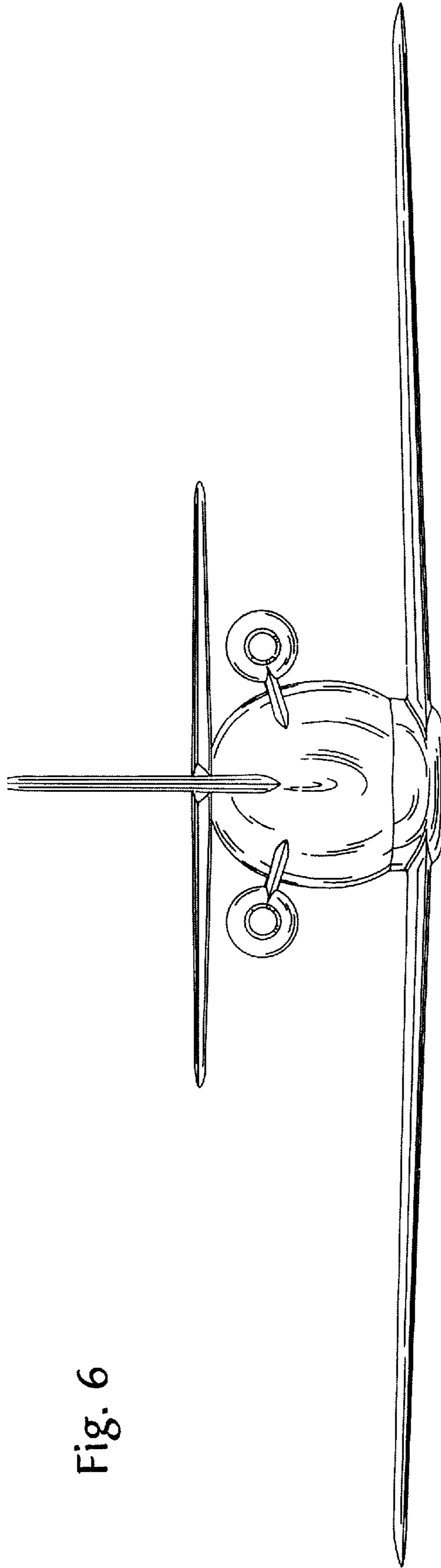

Fig. 6

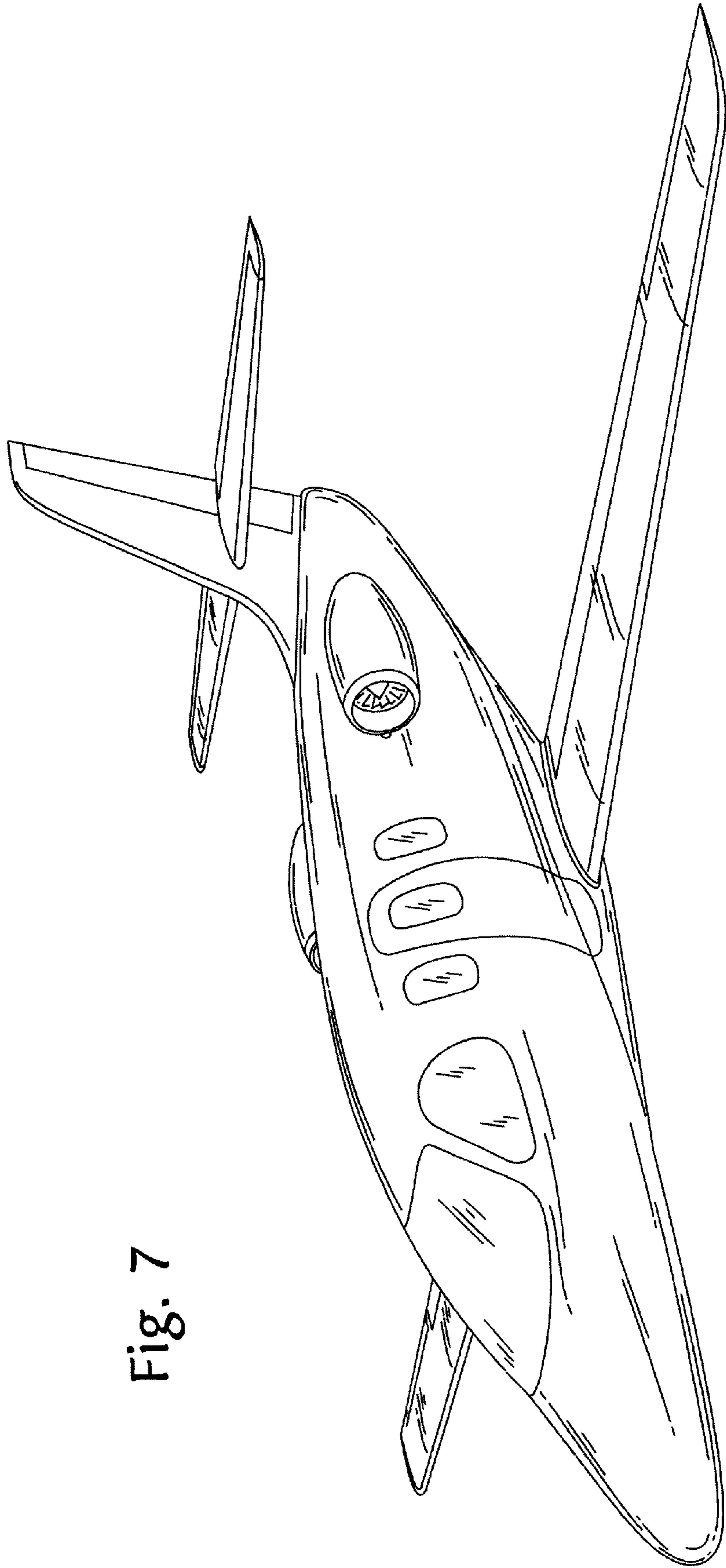

Fig. 7