



US00D418087S

United States Patent [19]

Ueno

[11] **Patent Number: Des. 418,087**

[45] **Date of Patent: ** Dec. 28, 1999**

[54] **AUTOMOBILE**

D. 401,185 11/1998 McGovern D12/91
D. 402,319 12/1998 Fu D12/91

[75] Inventor: **Shigeo Ueno**, Wako, Japan

FOREIGN PATENT DOCUMENTS

921718 3/1995 Japan .

[73] Assignee: **Honda Giken Kogyo Kabushiki Kaisha**, Tokyo, Japan

[**] Term: **14 Years**

Primary Examiner—Melody N. Brown
Attorney, Agent, or Firm—Nikaido, Marmelstein, Murray & Oram LLP

[21] Appl. No.: **29/084,452**

[22] Filed: **Mar. 3, 1998**

[57] CLAIM

[30] Foreign Application Priority Data

The ornamental design for an automobile, as shown and described.

Sep. 3, 1997 [JP] Japan 9-66681

DESCRIPTION

[51] **LOC (6) Cl.** **12-08**

[52] **U.S. Cl.** **D12/91**

[58] **Field of Search** D12/90-92; 296/185

FIG. 1 is a left-front perspective view of an automobile showing our new design;
FIG. 2 is a left-rear perspective view thereof;
FIG. 3 is a front view thereof;
FIG. 4 is a rear view thereof;
FIG. 5 is a left side view thereof;
FIG. 6 is a right side view thereof and,
FIG. 7 is a top plan view thereof.

[56] References Cited

U.S. PATENT DOCUMENTS

D. 336,737 6/1993 Cannara D12/91
D. 346,990 5/1994 Abbott et al. D12/91
D. 391,898 3/1998 Yoshikawa et al. D12/91
D. 397,065 8/1998 Uematsu D12/91

1 Claim, 6 Drawing Sheets

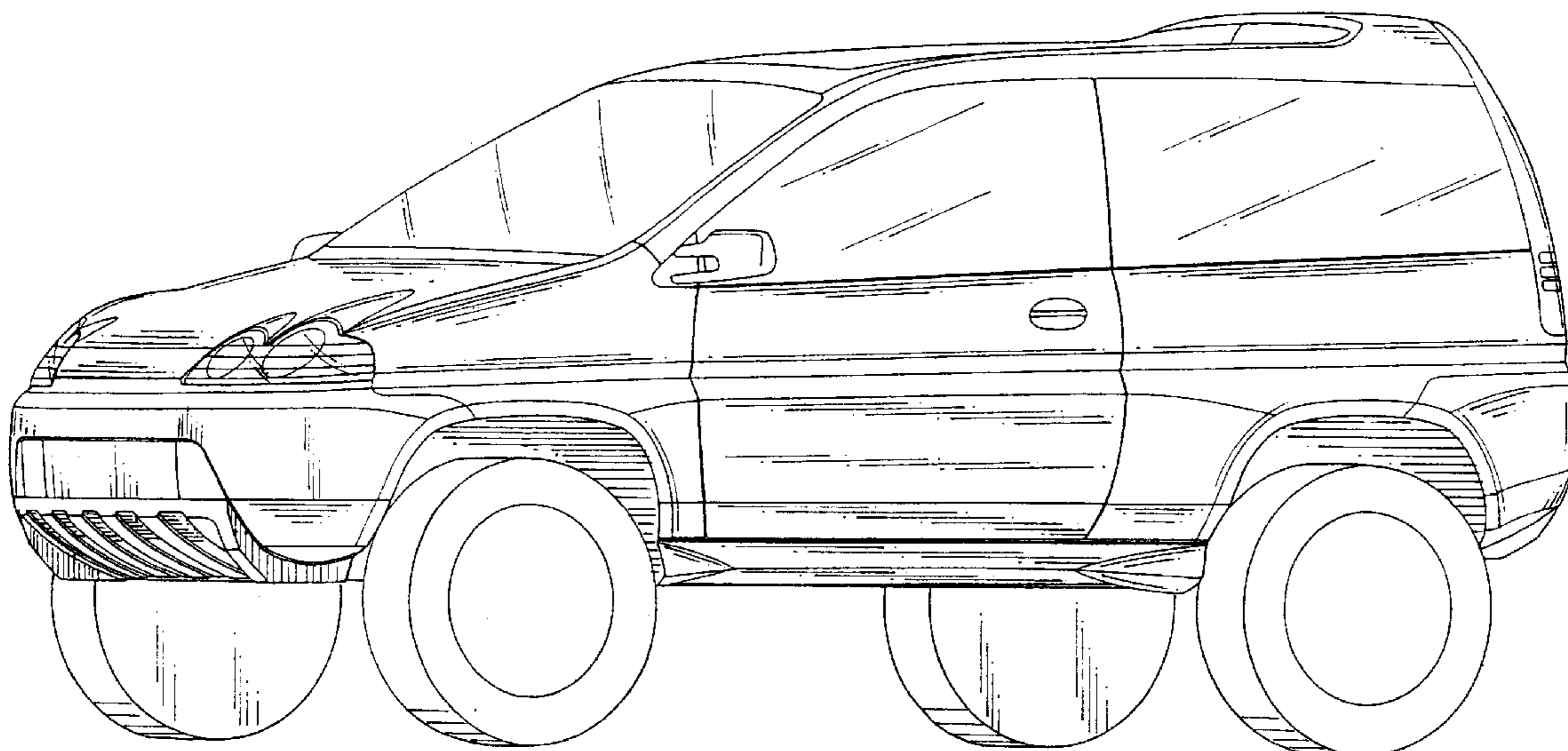

FIG. 1

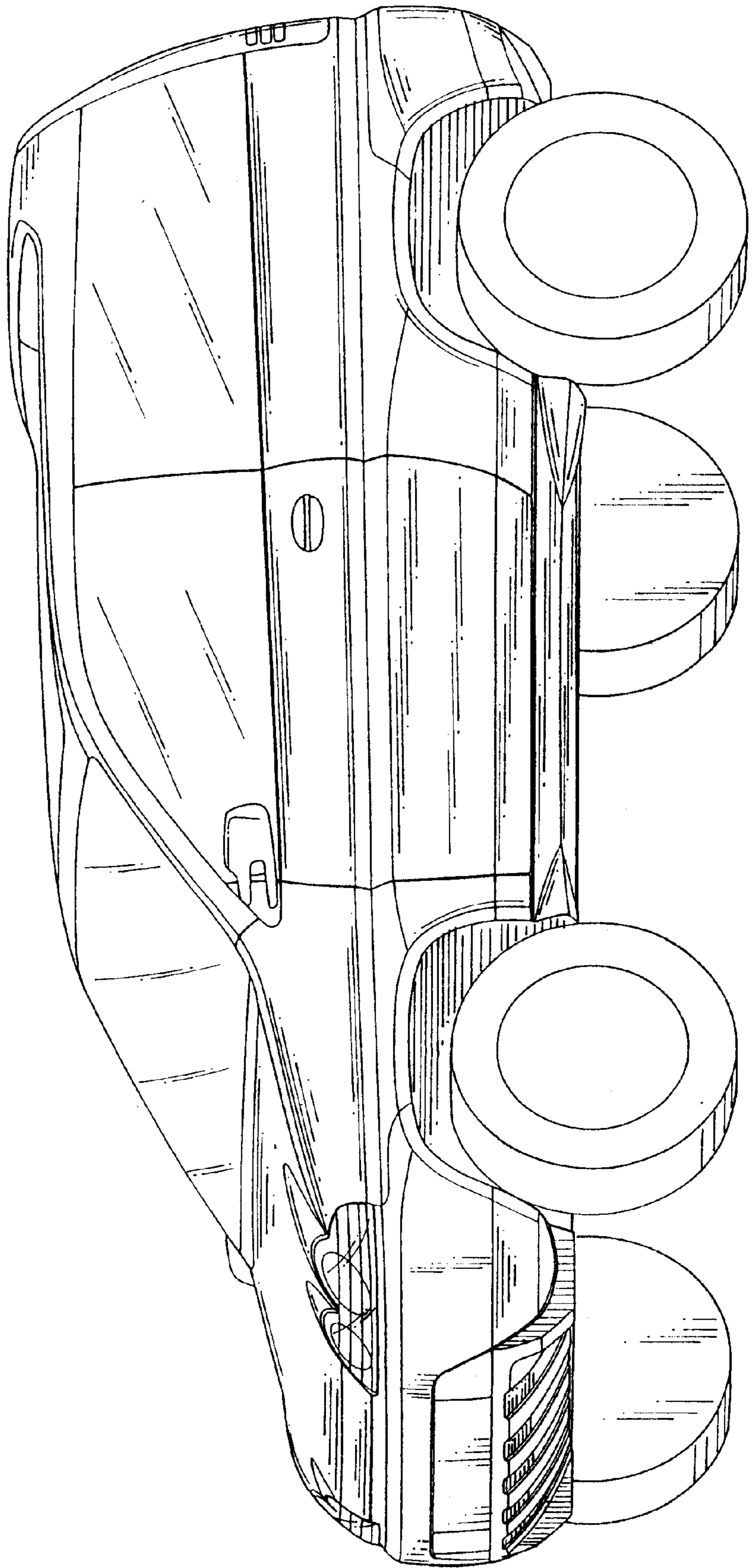

FIG. 2

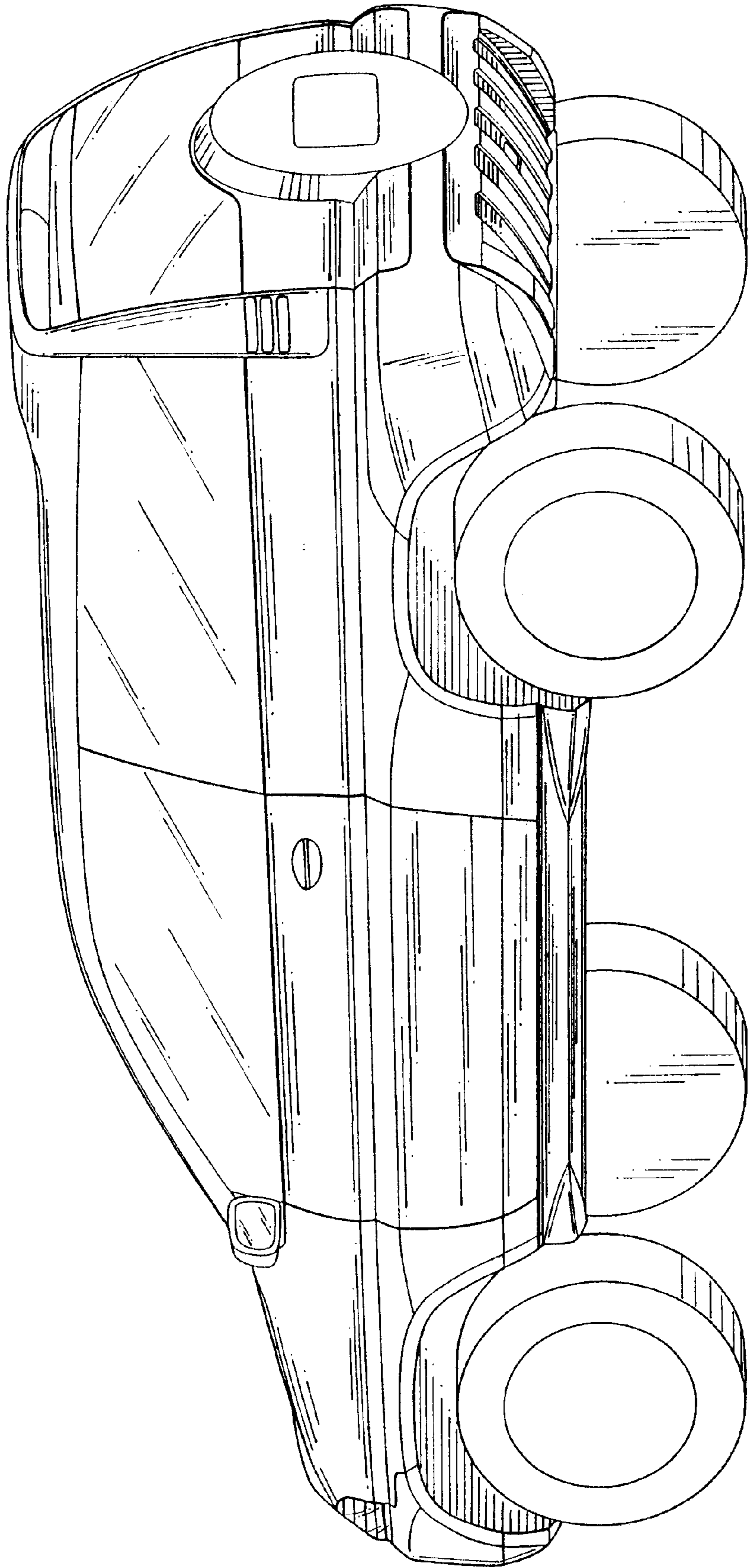

FIG. 4

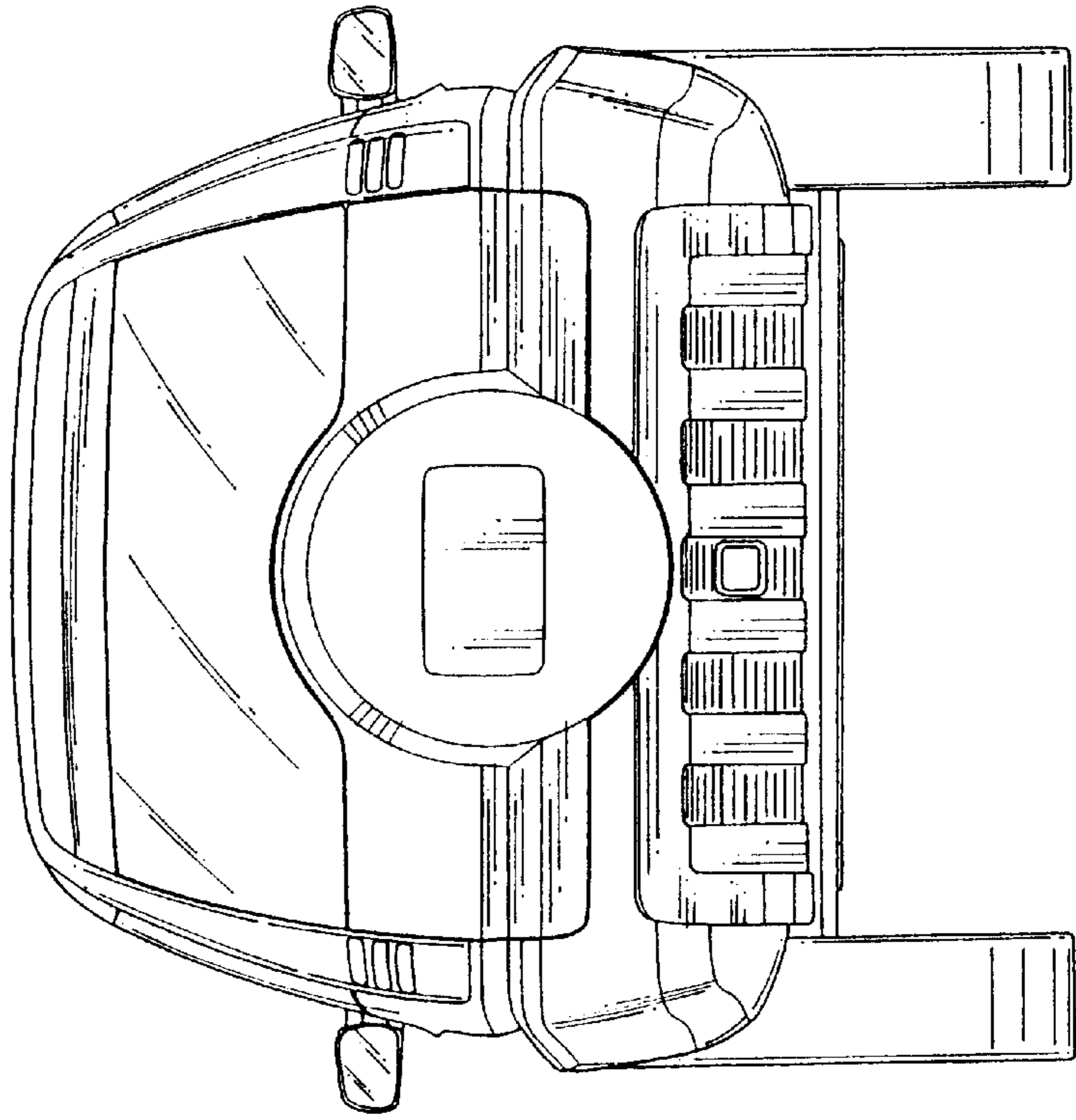

FIG. 3

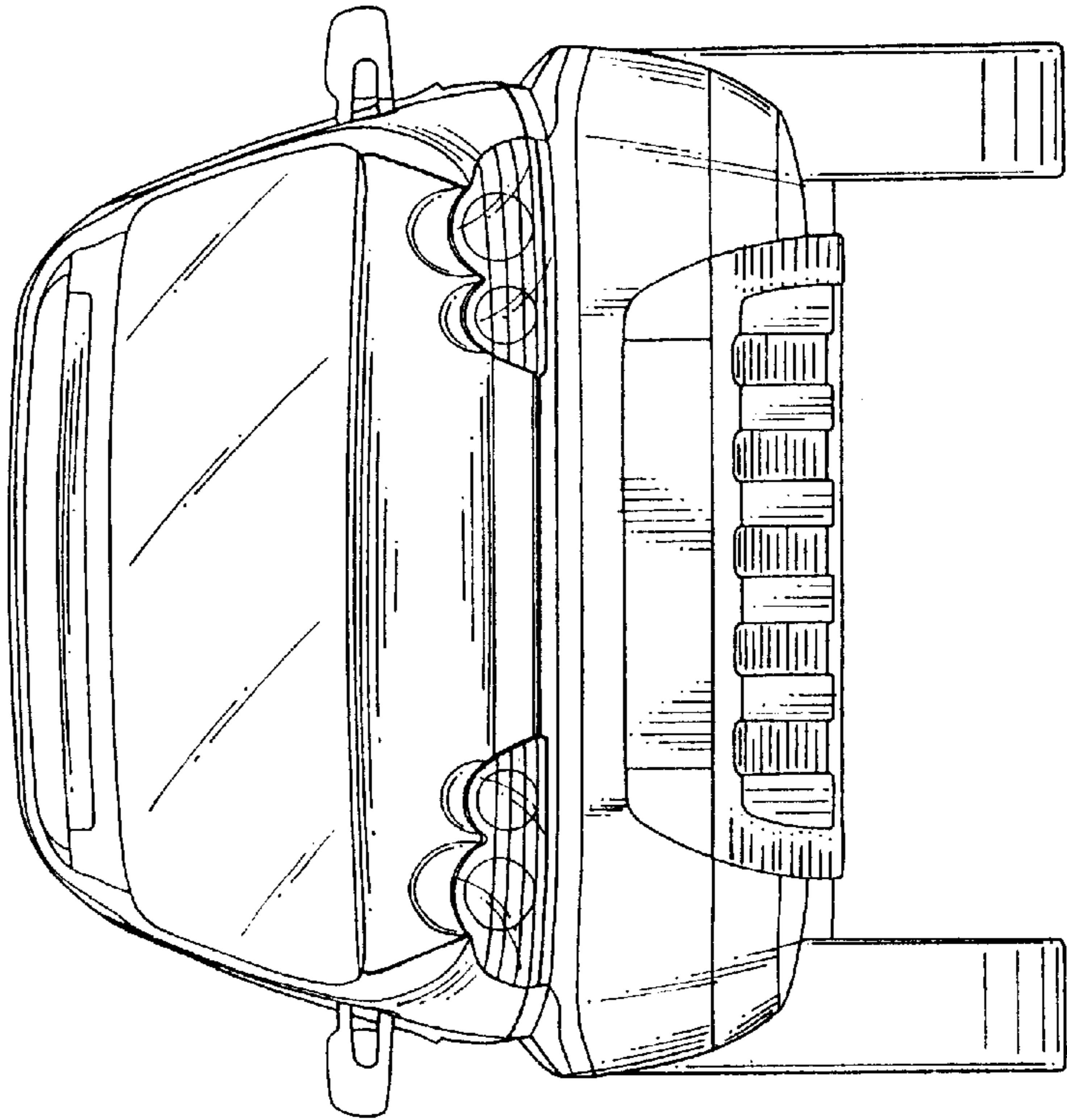

FIG. 5

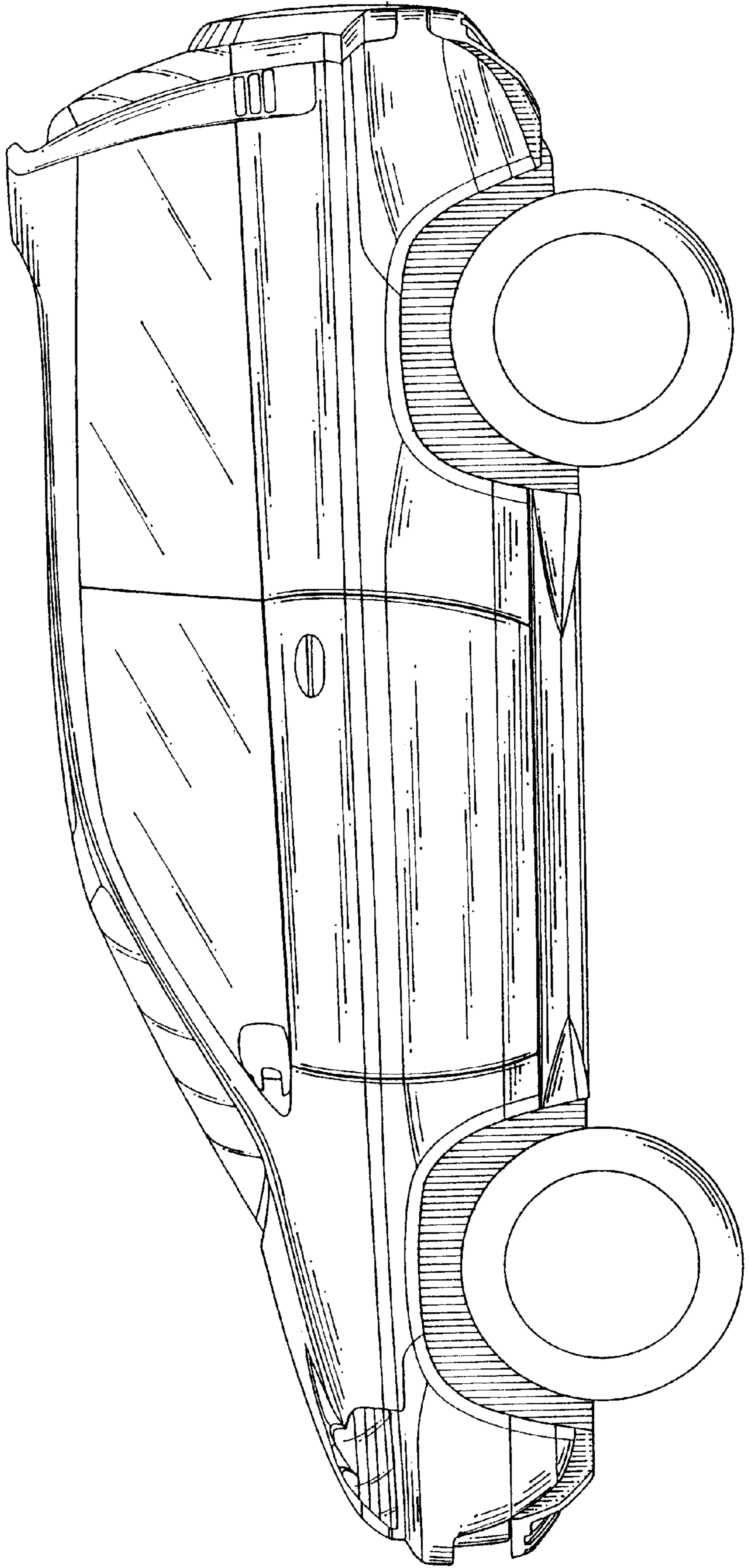

FIG. 6

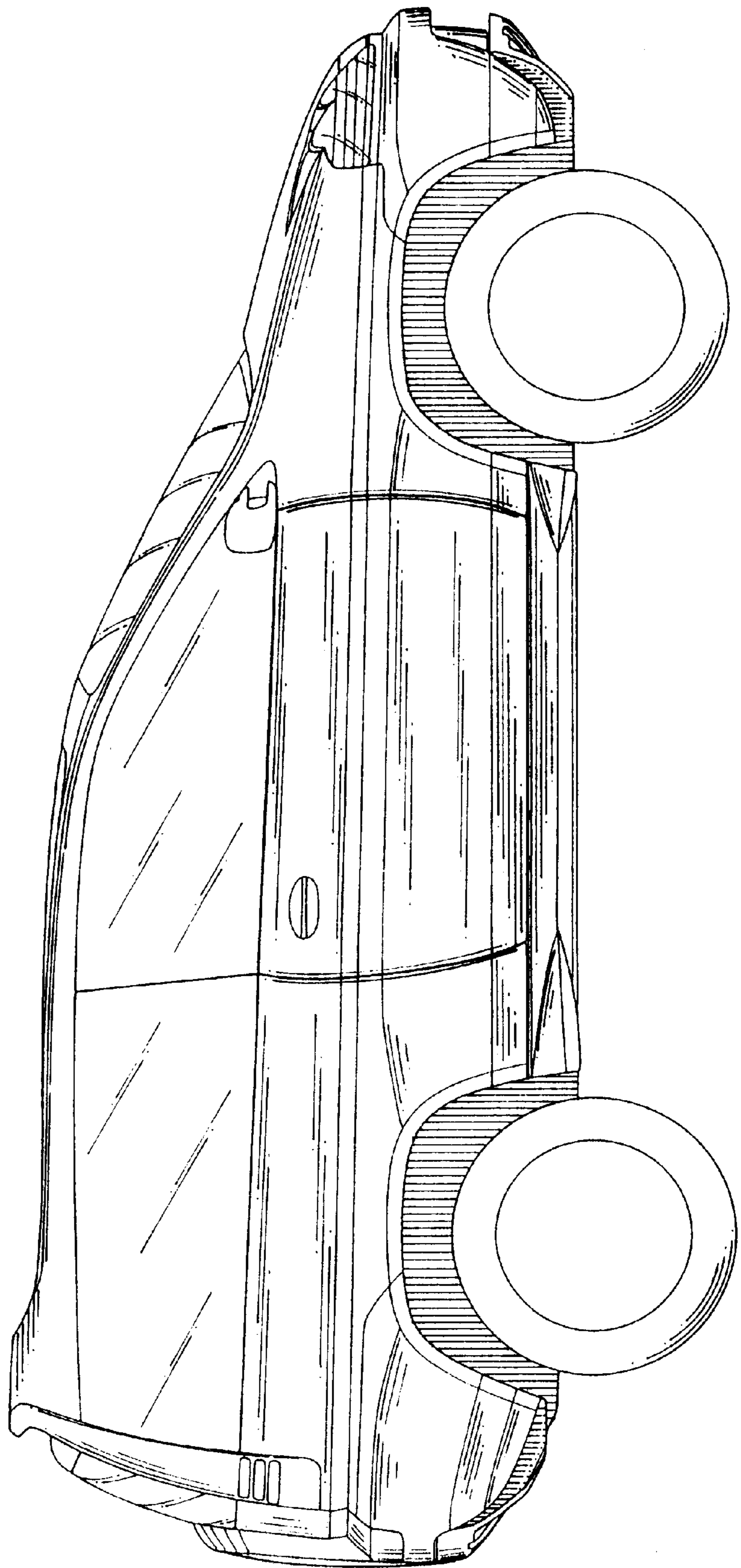

FIG. 7

