



US00D417675S

United States Patent [19]

Yaguchi et al.

[11] Patent Number: **Des. 417,675**

[45] Date of Patent: **** Dec. 14, 1999**

[54] **INTERNAL COMBUSTION ENGINE
STARTER CASING**

D. 302,982 8/1989 Bainbridge, III D15/5
D. 406,149 2/1999 Brinkley et al. D15/5
5,148,713 9/1992 Kimura et al. 74/6

[75] Inventors: **Tadahiro Yaguchi, Wako; Taro Kihara, Takasaki; Shigeaki Kuwabara, Wako, all of Japan**

Primary Examiner—Ralf Seifert
Attorney, Agent, or Firm—Adams & Wilks

[73] Assignees: **Honda Giken Kogyo Kabushiki Kaisha; Starting Industrial Co., Ltd., both of Japan**

[57] CLAIM

[**] Term: **14 Years**

The ornamental design for an internal combustion engine starter casing, as shown and described.

[21] Appl. No.: **29/094,304**

DESCRIPTION

[22] Filed: **Sep. 30, 1998**

FIG. 1 is a front elevational view of the casing for an internal combustion engine starter, showing our new design;

[30] Foreign Application Priority Data

Mar. 31, 1998 [JP] Japan 10-8920

FIG. 2 is a top plan view thereof;

FIG. 3 is a bottom plan view thereof;

[51] **LOC (6) Cl.** **15-01**

FIG. 4 is a right side elevational view thereof;

[52] **U.S. Cl.** **D15/5**

FIG. 5 is a left side elevational view thereof;

[58] **Field of Search** D15/1, 4, 5; 290/38 C, 290/38 R; 123/185.3, 634, 179 AS; 74/6, 7 A

FIG. 6 is a rear elevational view thereof; and,

FIG. 7 is a cross-sectional view taken along line 7—7 of FIG. 1.

[56] References Cited

U.S. PATENT DOCUMENTS

D. 287,130 12/1986 Tilton, Jr. D15/5

1 Claim, 2 Drawing Sheets

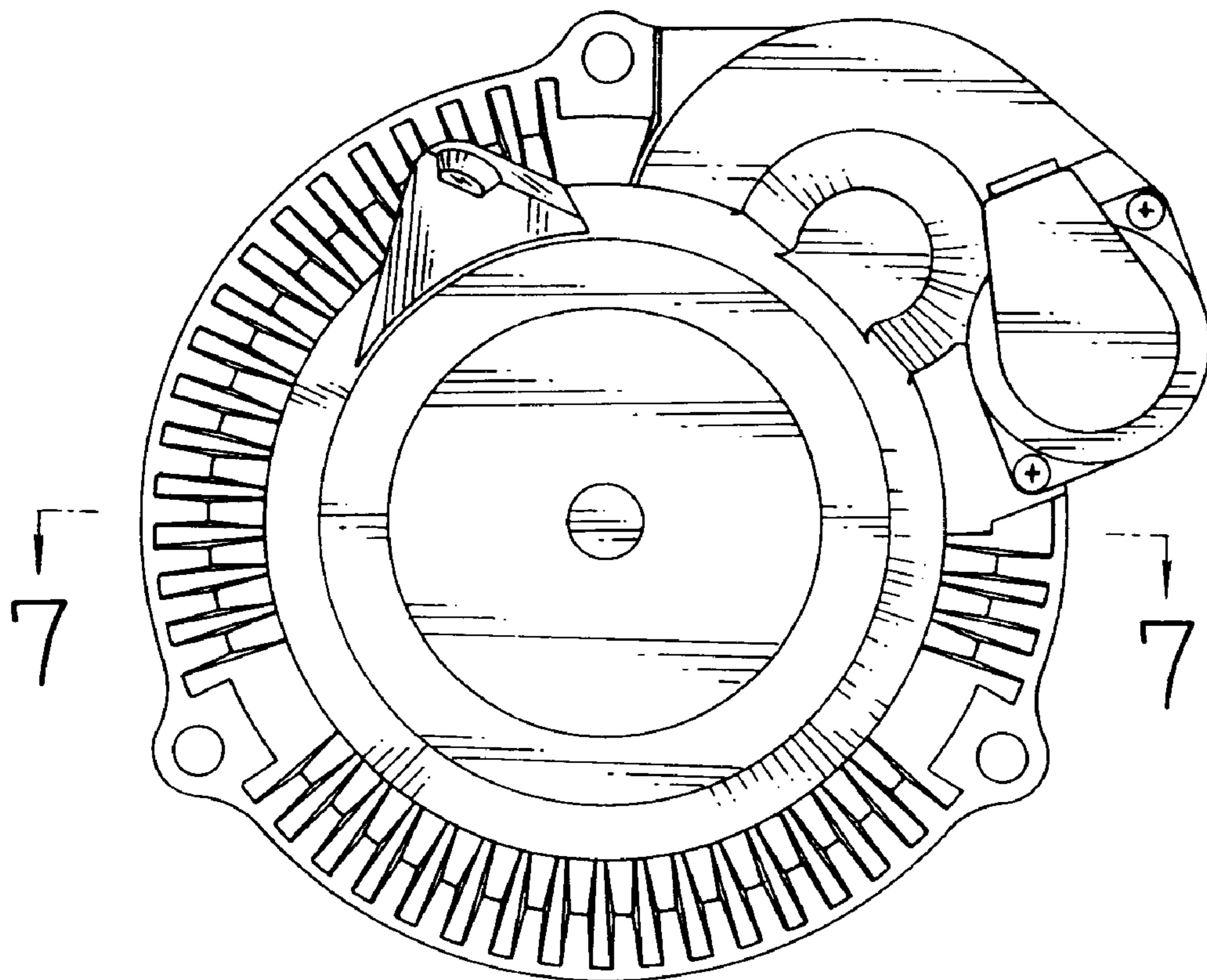

FIG. 2

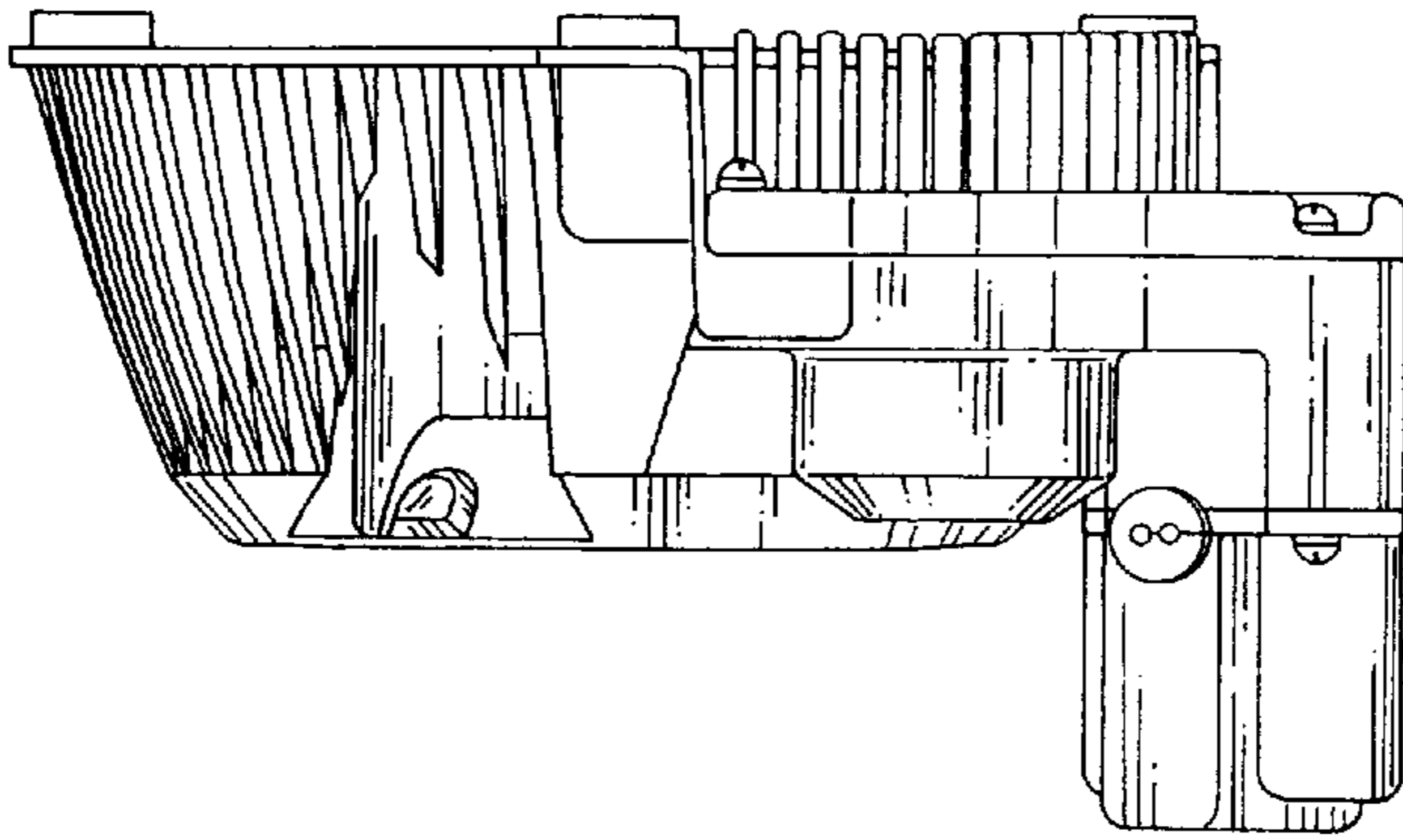

FIG. 1

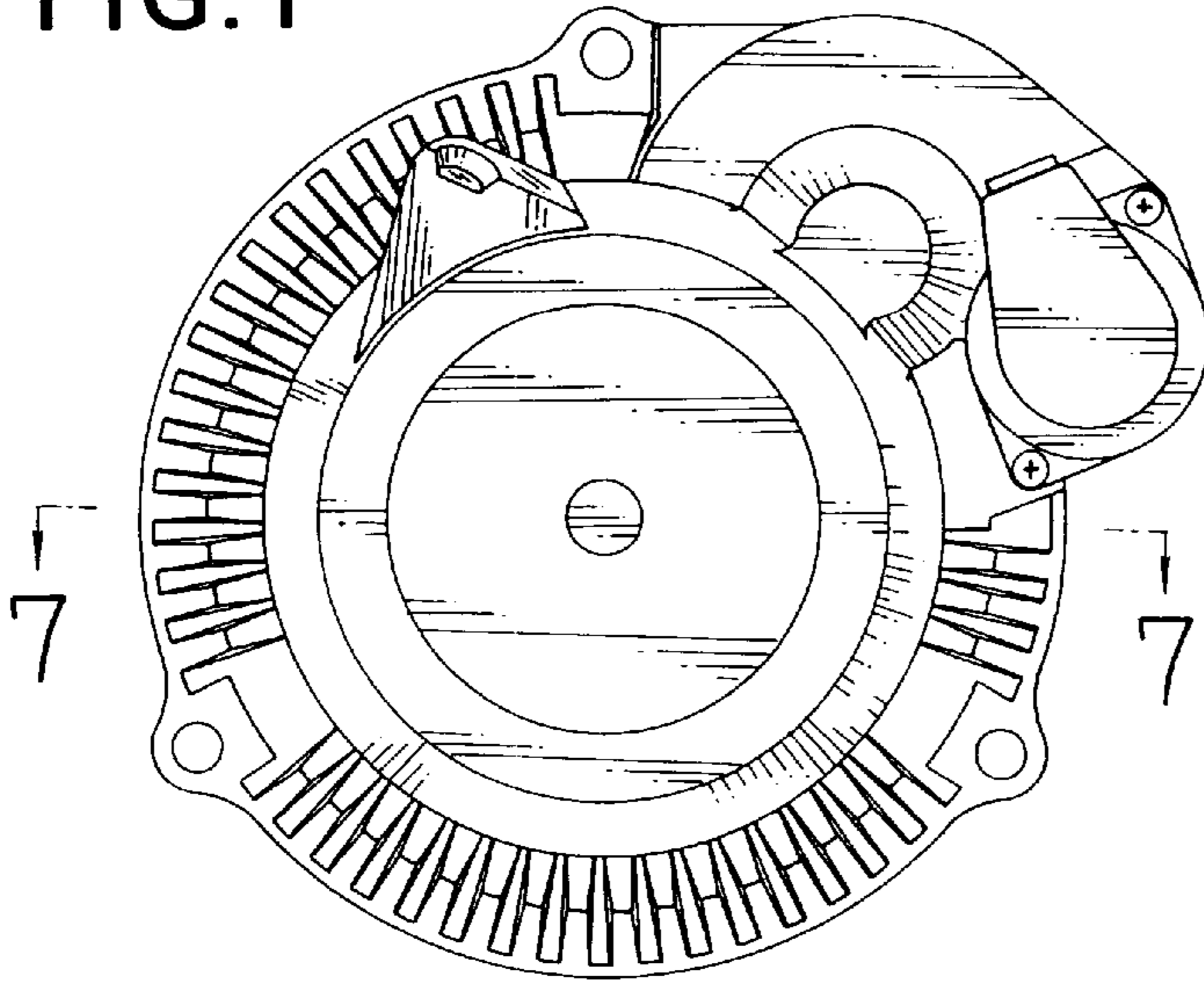

FIG. 4

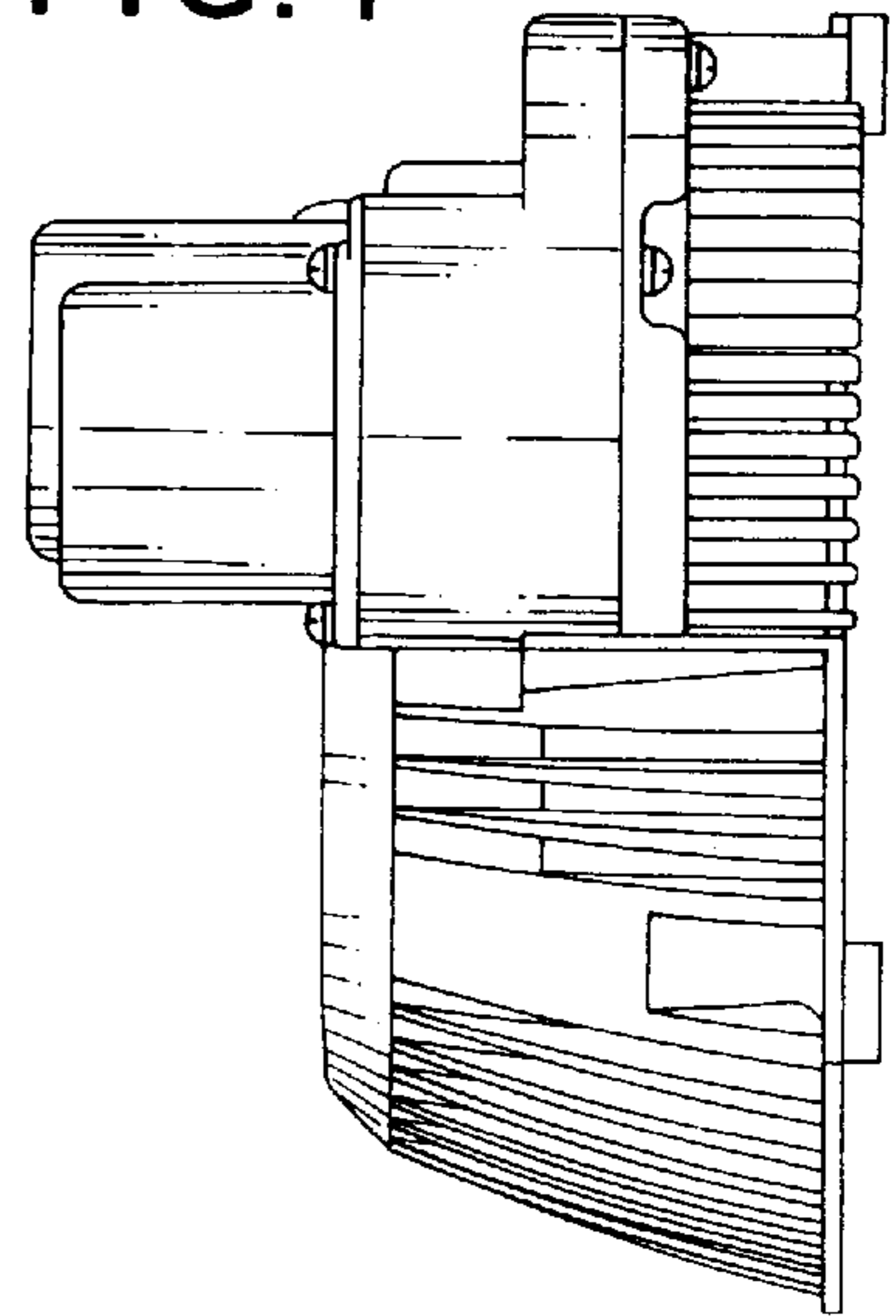

FIG. 3

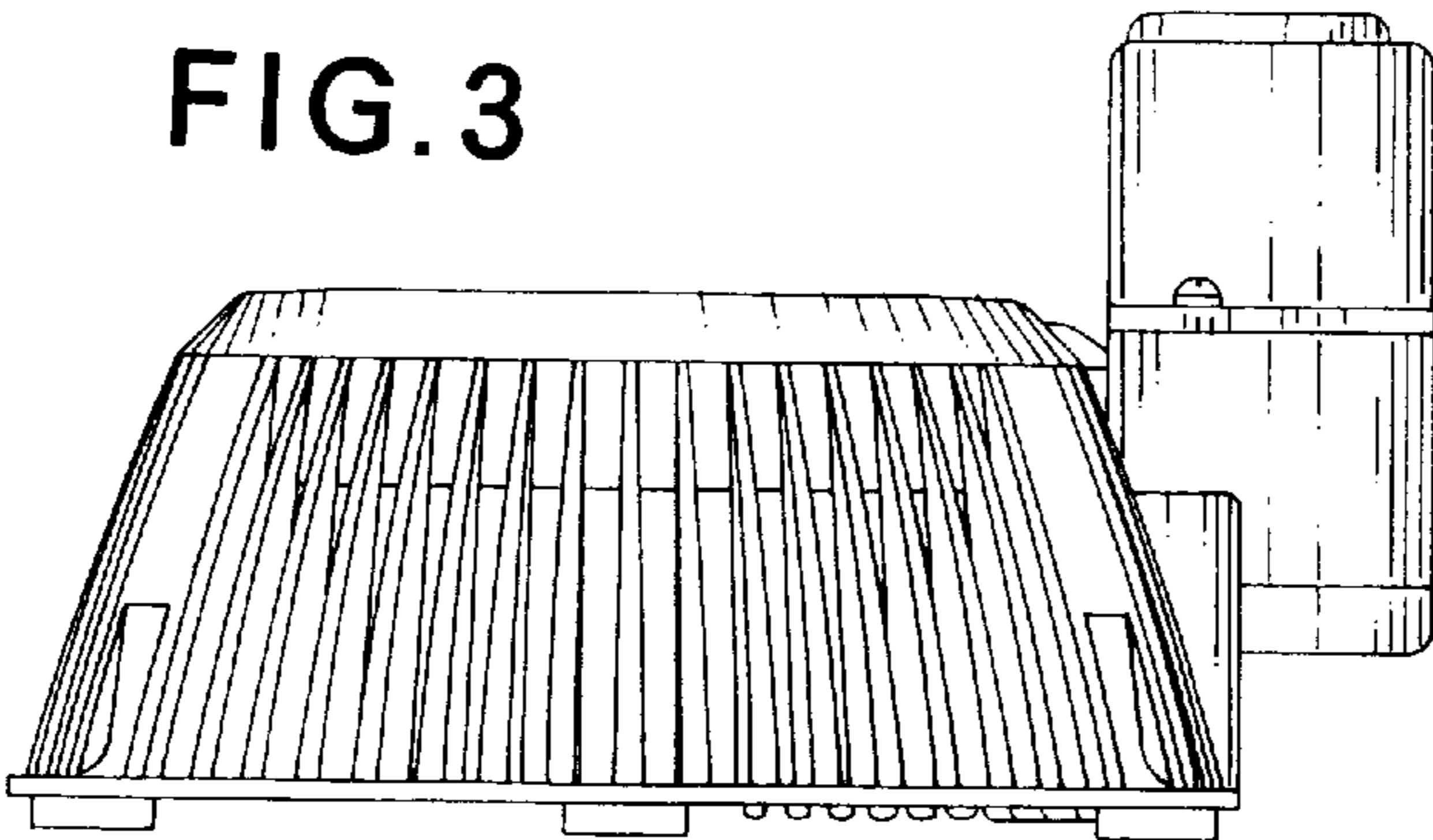

FIG. 5

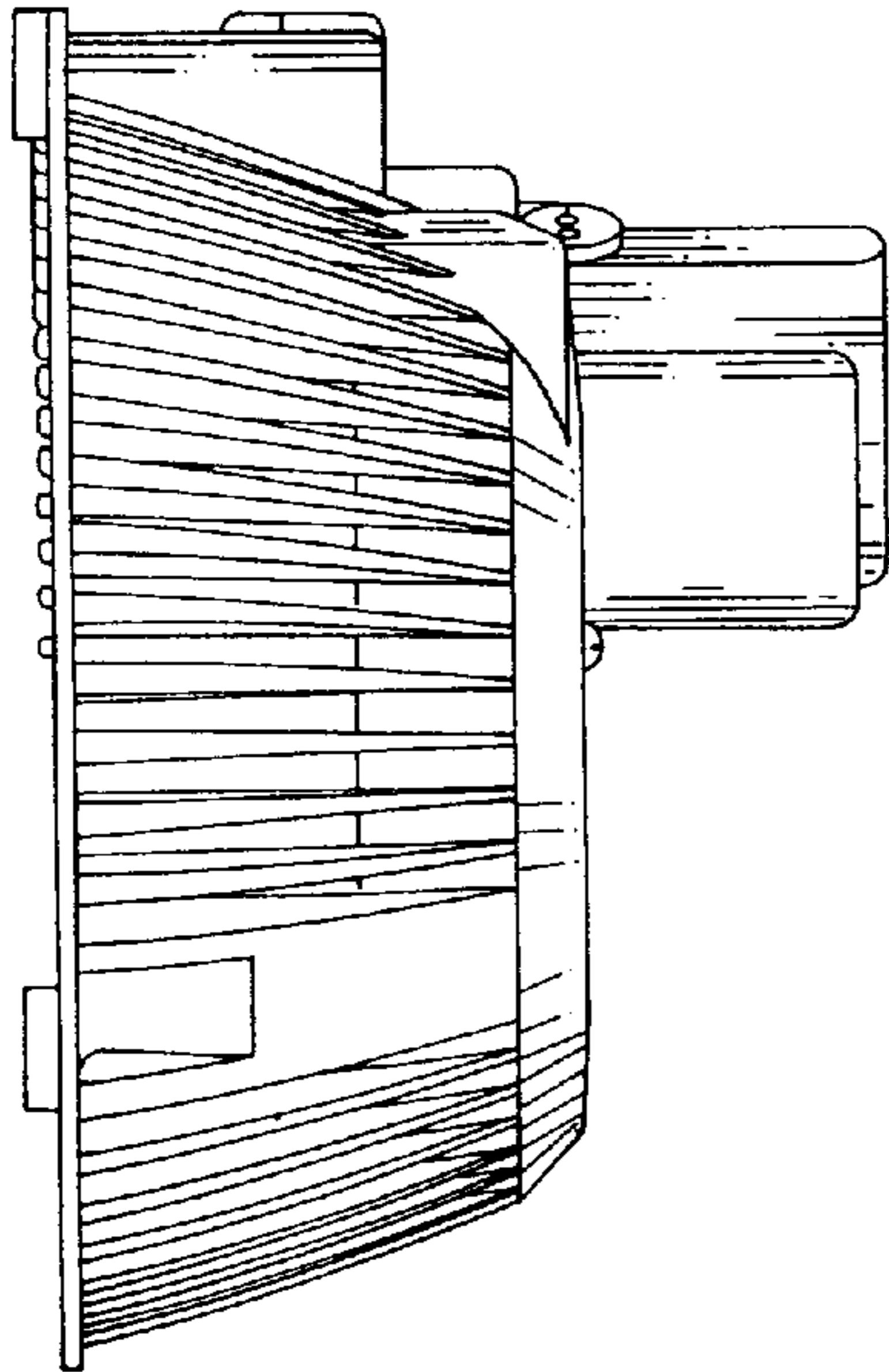

FIG. 6

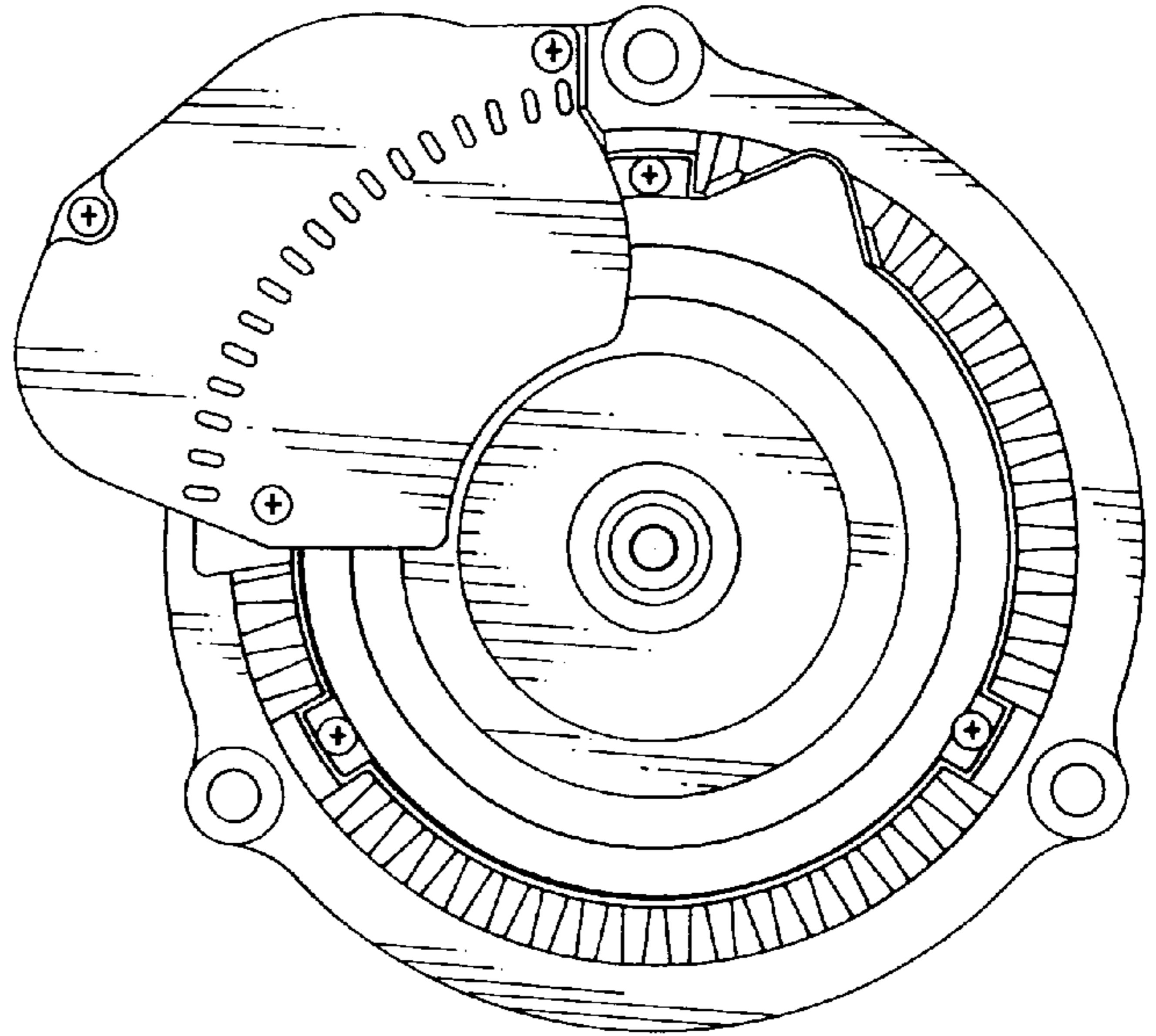

FIG. 7

