



US00D417647S

United States Patent [19]
Jardine

[11] **Patent Number: Des. 417,647**

[45] **Date of Patent: ** Dec. 14, 1999**

[54] **CARRIER FOR ALL TERRAIN VEHICLE**

[76] Inventor: **John W. Jardine**, 9173 Ustick Rd.,
Nampa, Id. 83687

[**] Term: **14 Years**

[21] Appl. No.: **29/089,203**

[22] Filed: **Jun. 9, 1998**

[51] **LOC (6) Cl.** **12-16**

[52] **U.S. Cl.** **D12/423**

[58] **Field of Search** D12/218, 423-424,
D12/415, 410; 224/539, 311, 540, 401-404,
410, 505-507, 526-528, 488-490; 296/37.1,
37.6-37.8, 37.16; 280/288.4

[56] **References Cited**

U.S. PATENT DOCUMENTS

D. 51,545	12/1917	Blake	D12/218
D. 235,583	6/1975	Parry	D12/423
D. 254,611	4/1980	Linto	D12/423
D. 258,501	3/1981	Winslow	D12/218
D. 293,705	1/1988	Sayward	D12/218 X
D. 372,454	8/1996	Murray, Sr.	D12/423
D. 378,671	4/1997	Herrs	D12/218
D. 387,327	12/1997	Ethridge	D12/423
D. 390,183	2/1998	Manwill	D12/218
4,844,309	7/1989	Aubin et al.	224/273
5,076,387	12/1991	Oka	296/37.1

Primary Examiner—Doris V. Coles
Assistant Examiner—Stacia Sinuik
Attorney, Agent, or Firm—Frank J. Dykas

[57] **CLAIM**

The ornamental design for carrier for all terrain vehicle, as shown and described.

DESCRIPTION

FIG. 1 is a front perspective view of a carrier for all terrain vehicle, showing my new design, it being understood that the portions of the interior which are not visible in FIG. 1 form no part of the claimed design;
FIG. 2 is an enlarged front plan view of the carrier for all terrain vehicle, shown with the lid in closed position;
FIG. 3 is an enlarged rear plan view thereof;
FIG. 4 is an enlarged right side view thereof;
FIG. 5 is an enlarged left side view thereof;
FIG. 6 is an enlarged top plan view thereof;
FIG. 7 is an enlarged bottom plan view thereof;
FIG. 8 is a front perspective view of a second embodiment of a carrier for all terrain vehicle, showing my new design, it being understood that the portions of the interior which are not visible in FIG. 8 form no part of the claimed design;
FIG. 9 is an enlarged front plan view of the second embodiment of the carrier for all terrain vehicle, shown with the lid in closed position;
FIG. 10 is an enlarged rear plan view thereof;
FIG. 11 is an enlarged right side view thereof;
FIG. 12 is an enlarged left side view thereof;
FIG. 13 is an enlarged top plan view thereof; and,
FIG. 14 is an enlarged bottom plan view thereof.
The broken line showing of environment is for illustrative purposes only and forms no part of the claimed design.

1 Claim, 12 Drawing Sheets

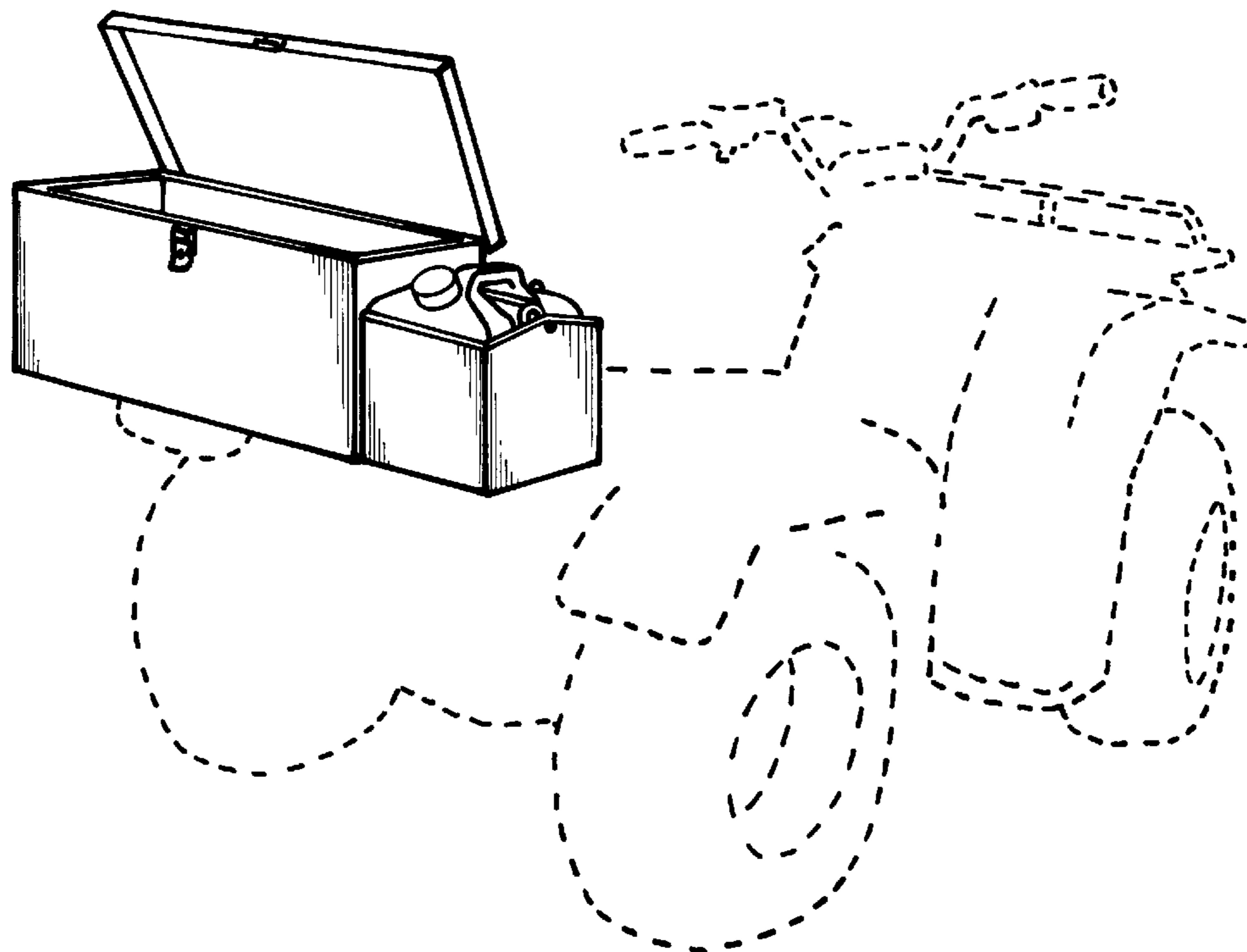

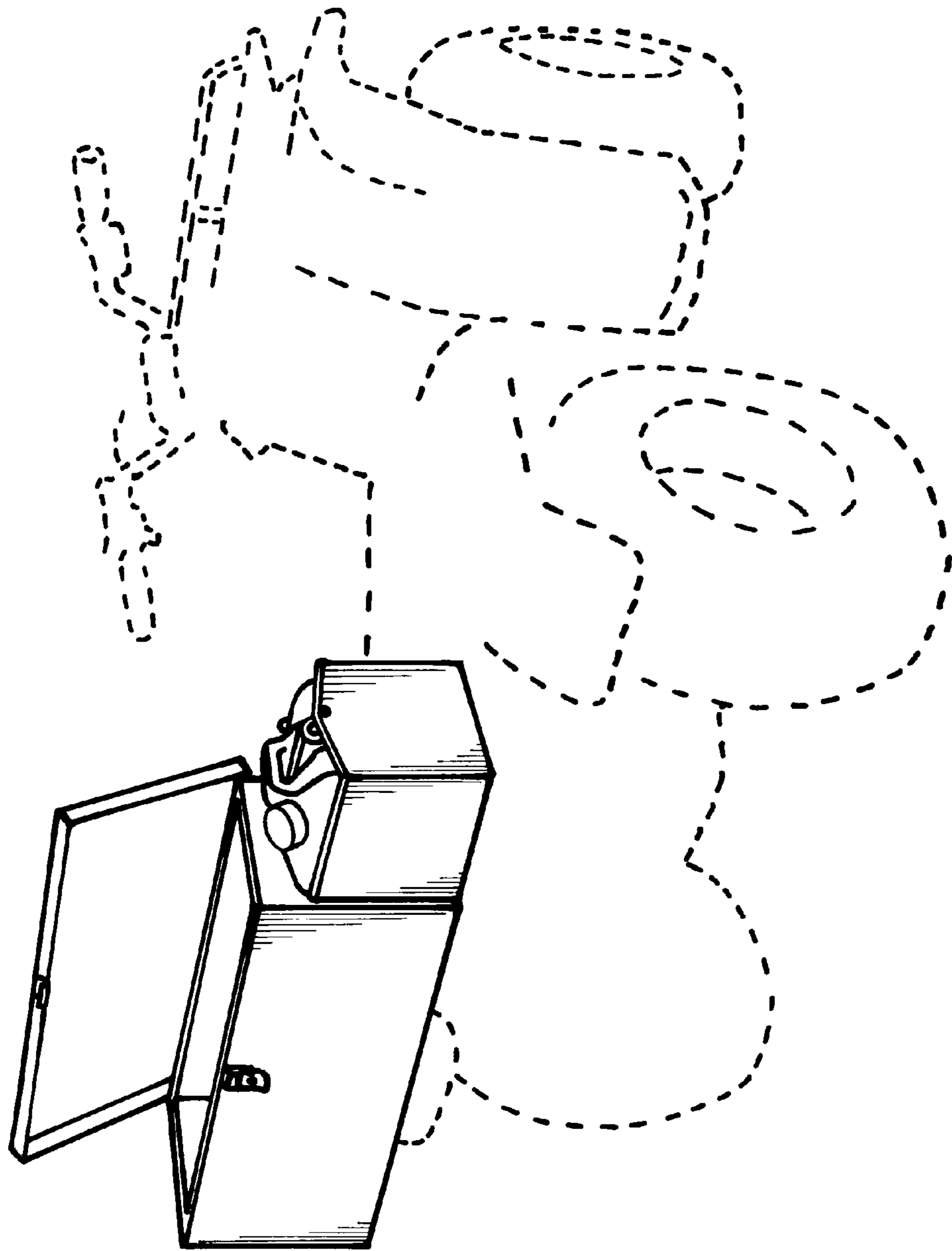

FIG. 1

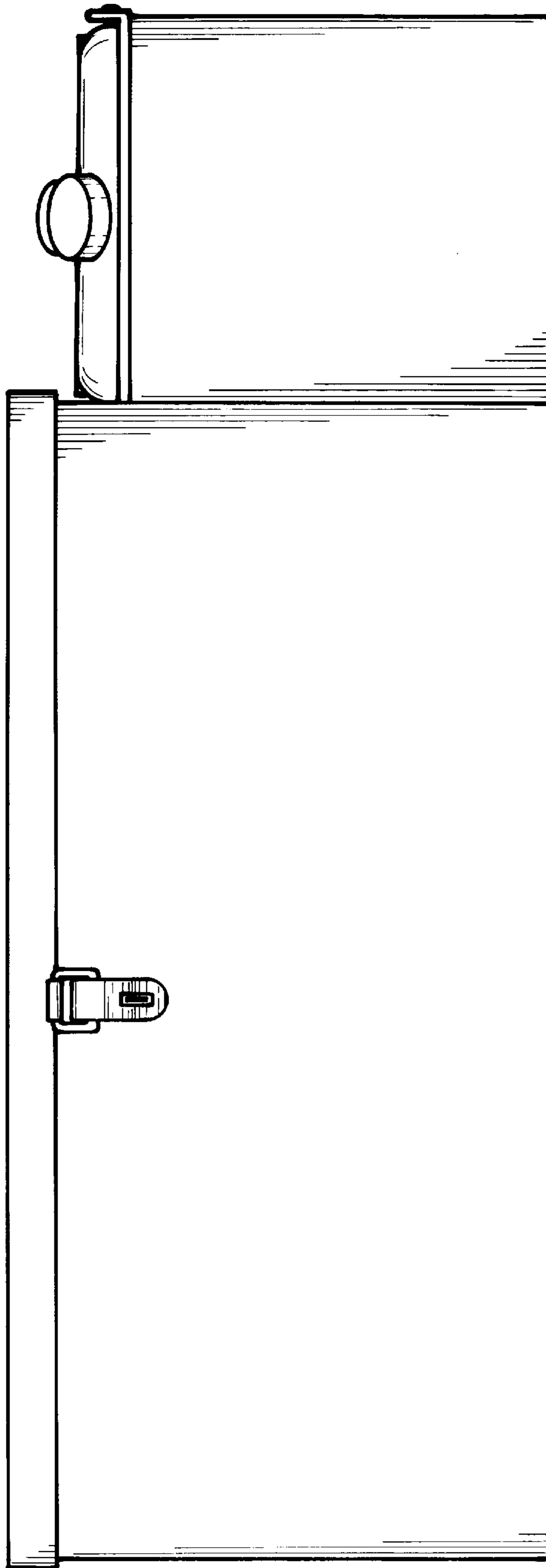

FIG. 2

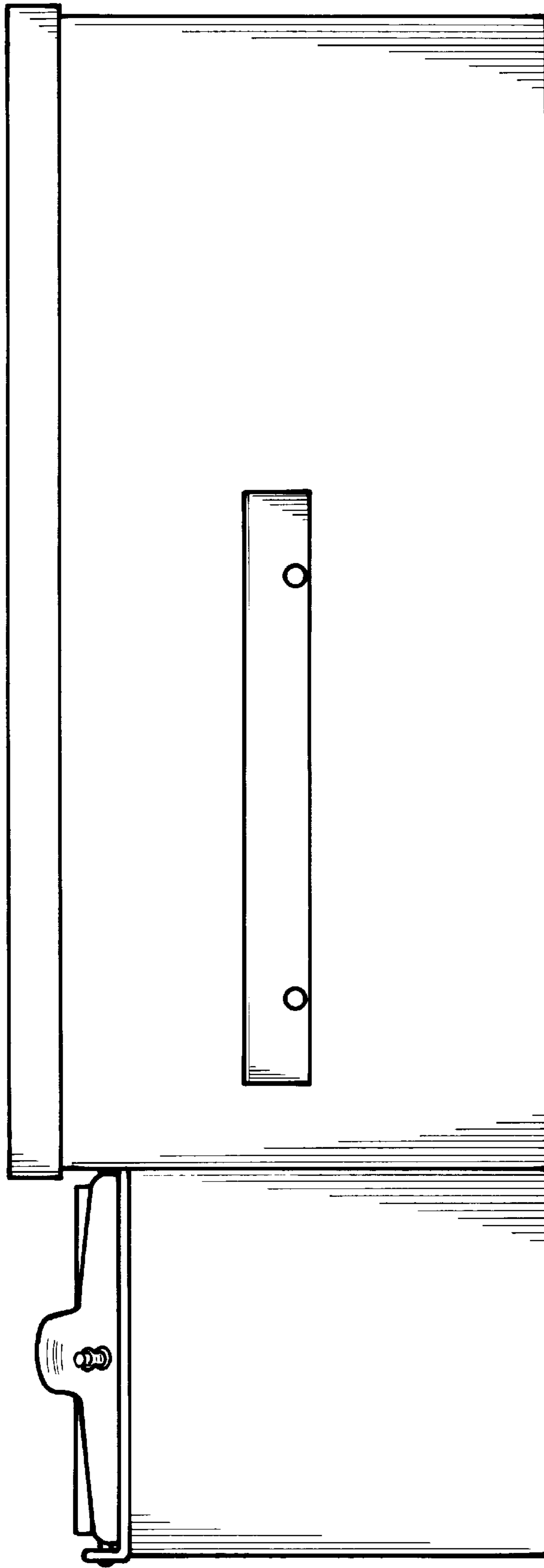

FIG. 3

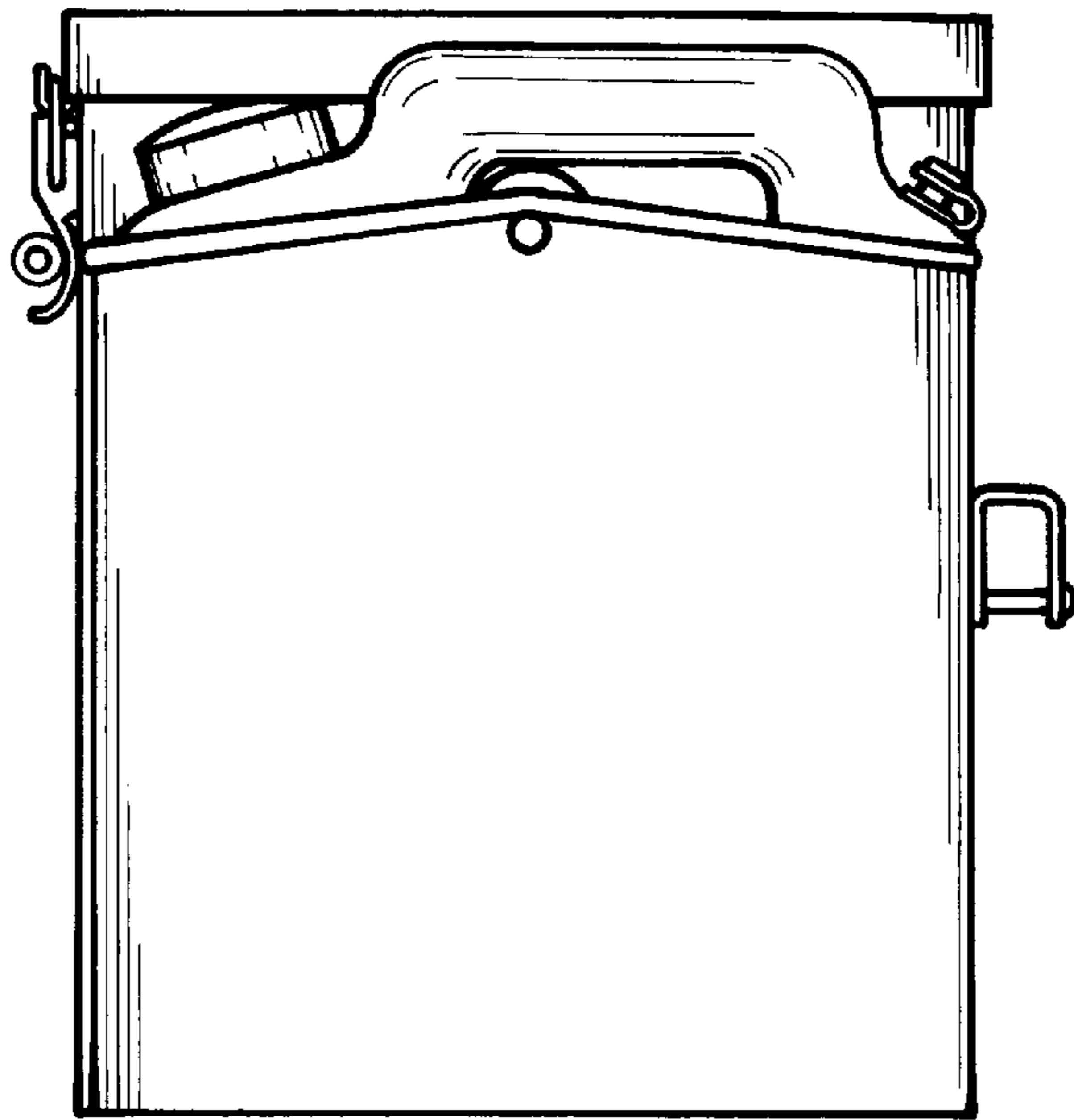

FIG. 4

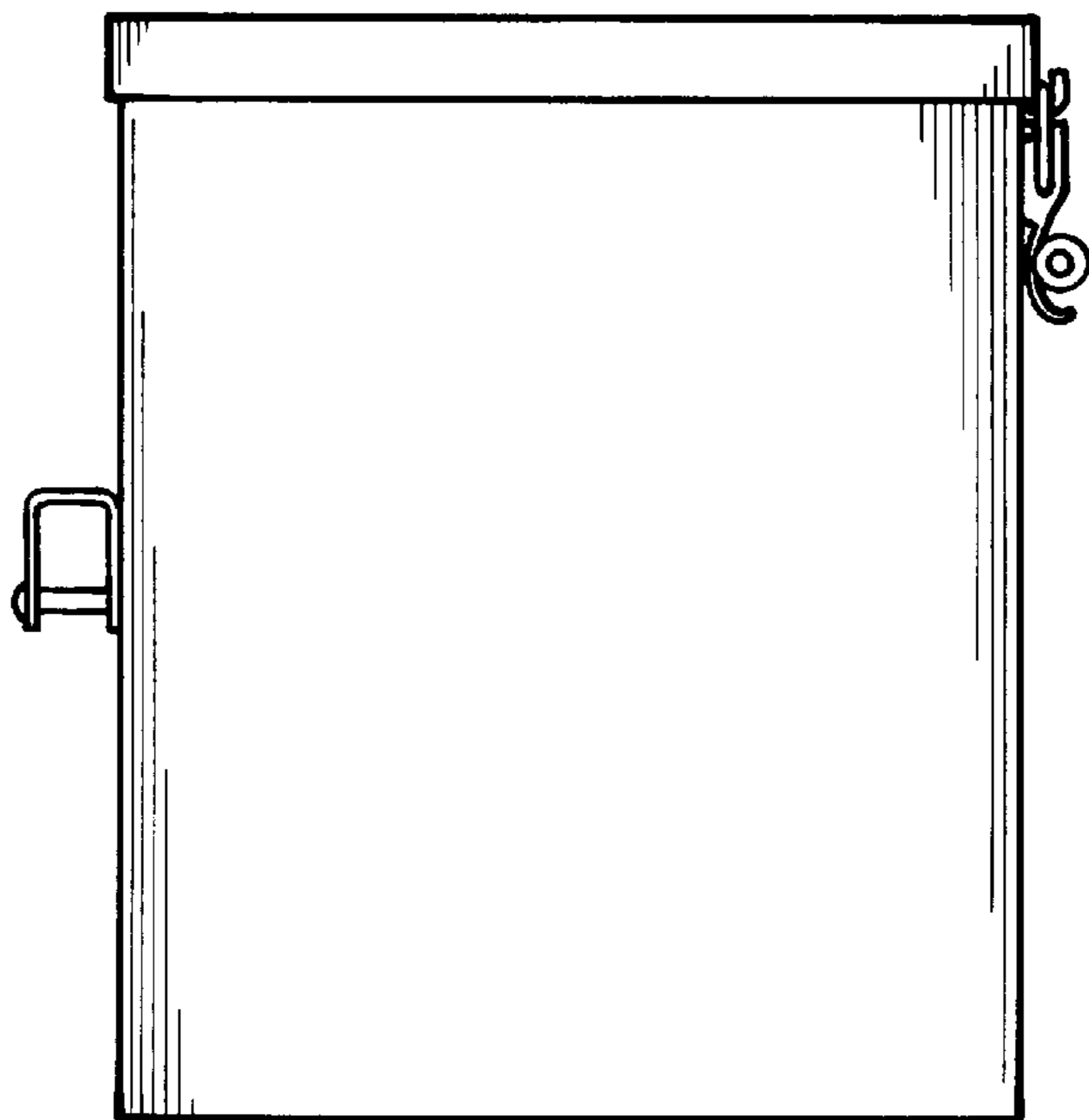

FIG. 5

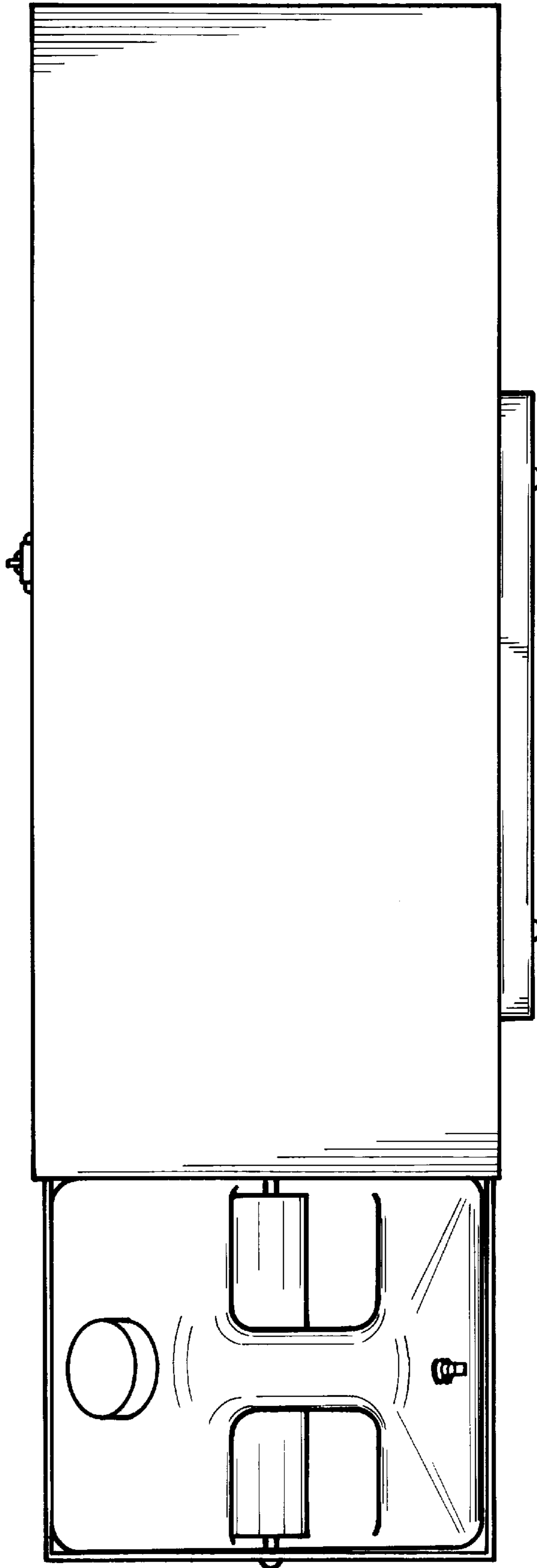

FIG. 6

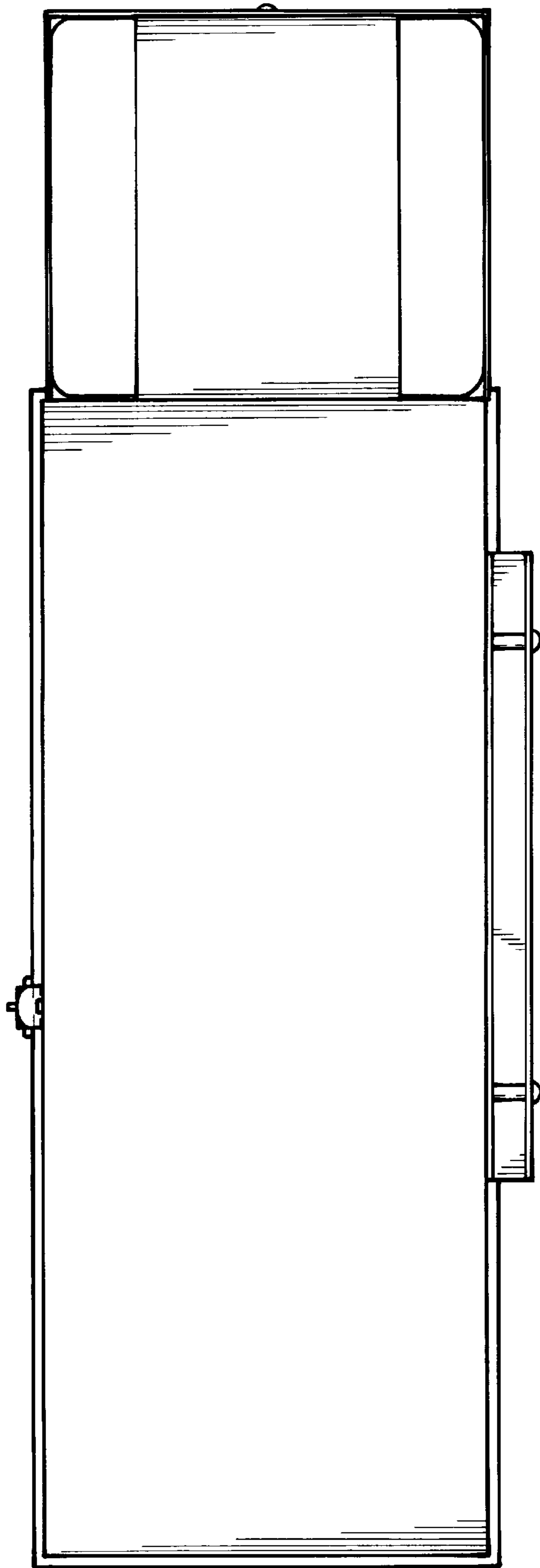

FIG. 7

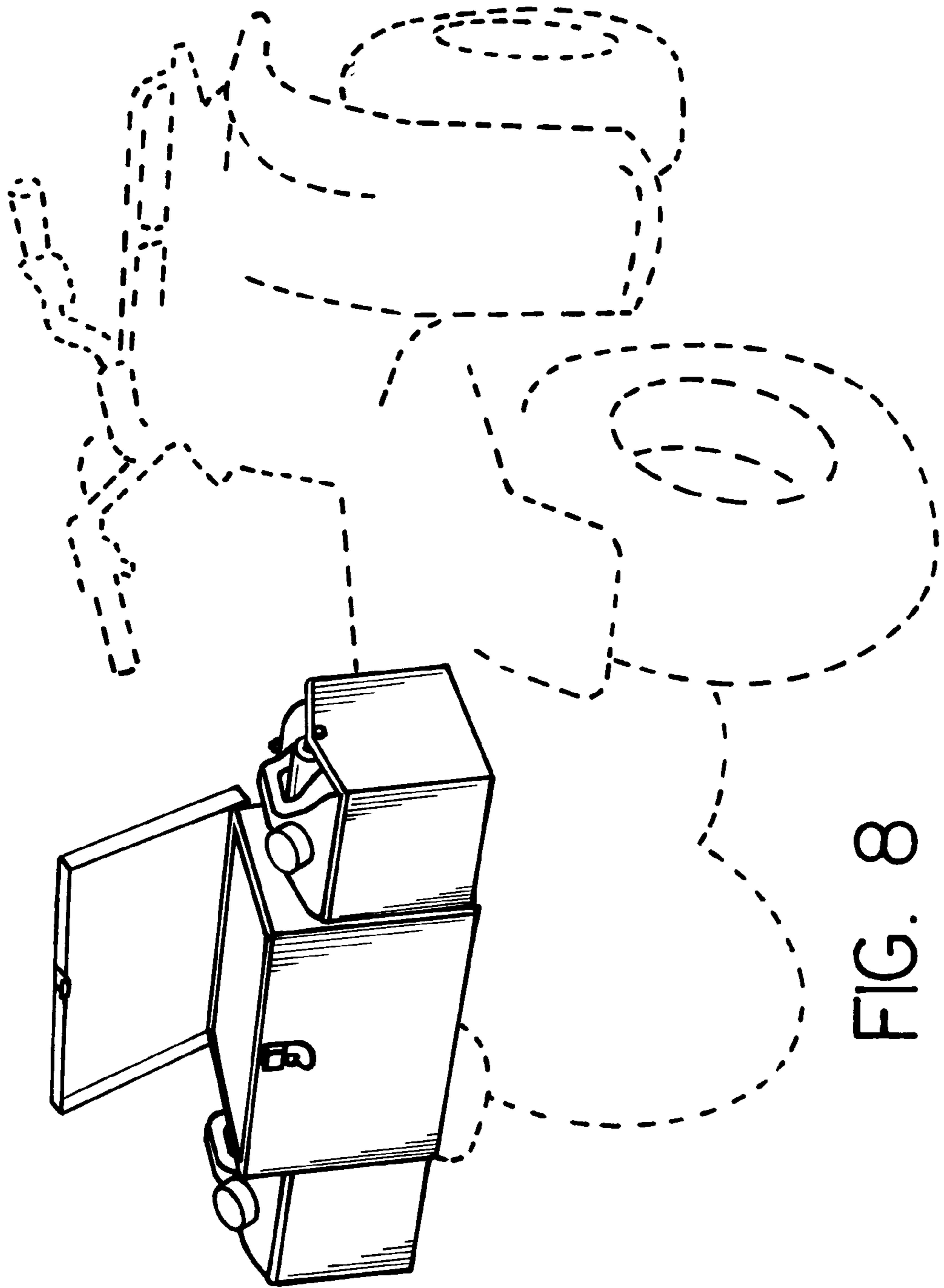

FIG. 8

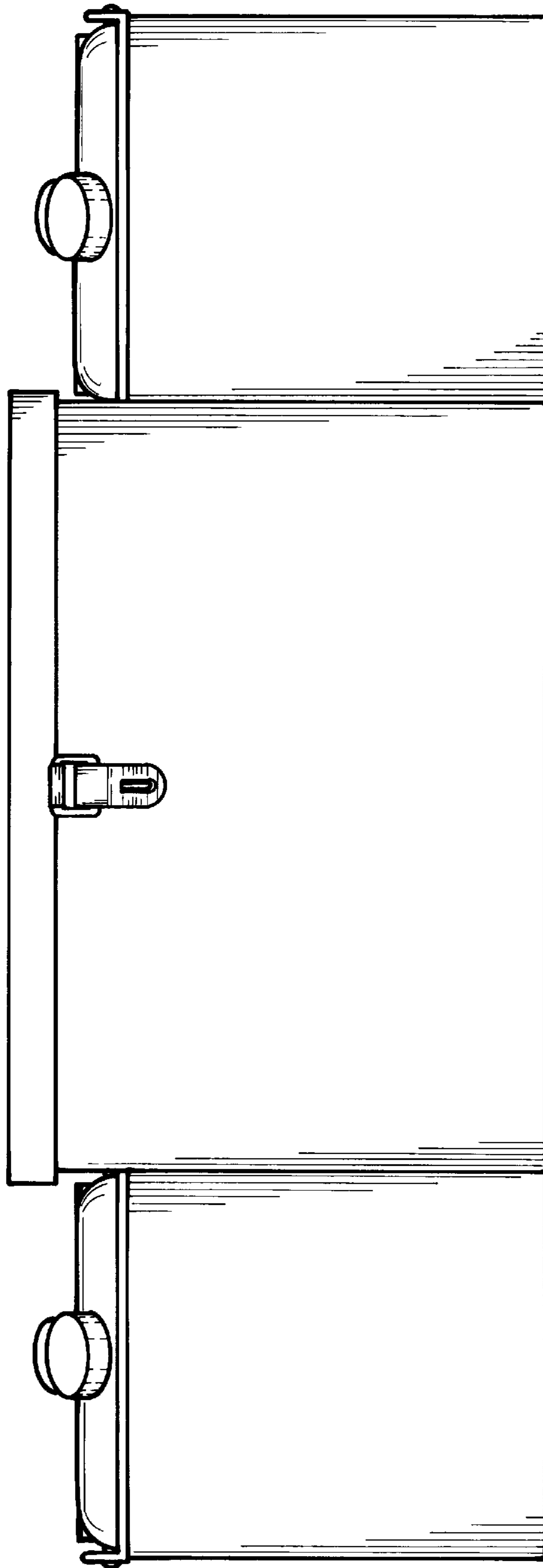

FIG. 9

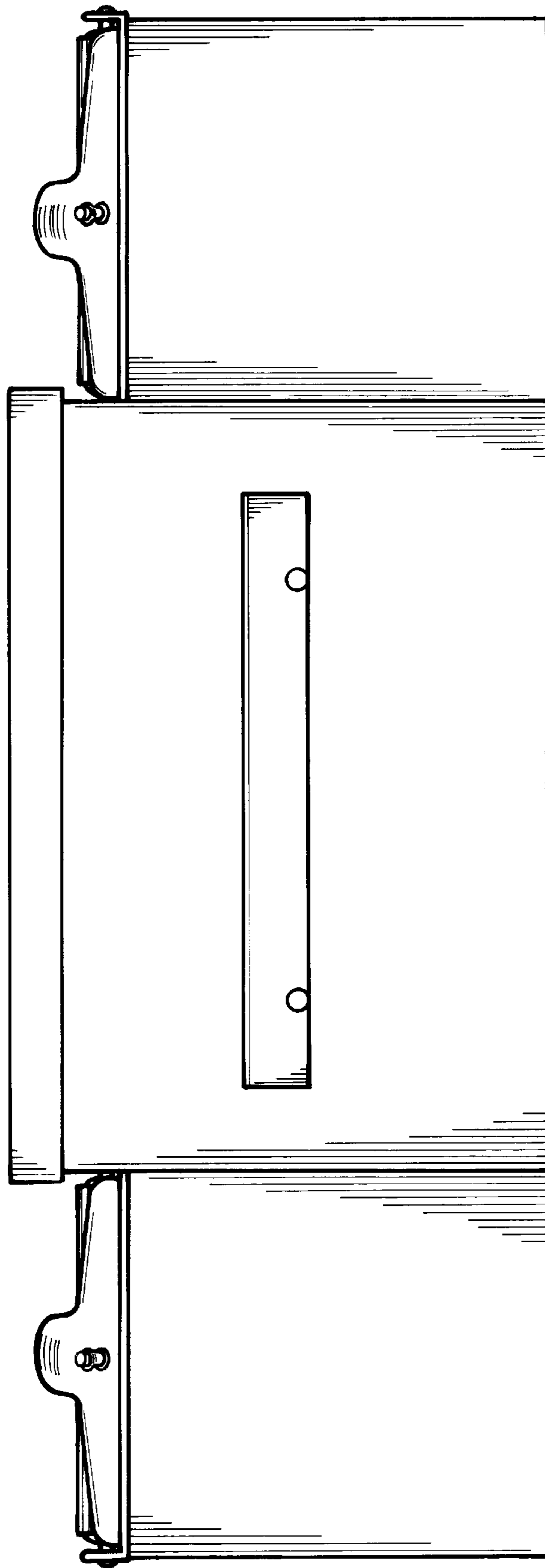

FIG. 10

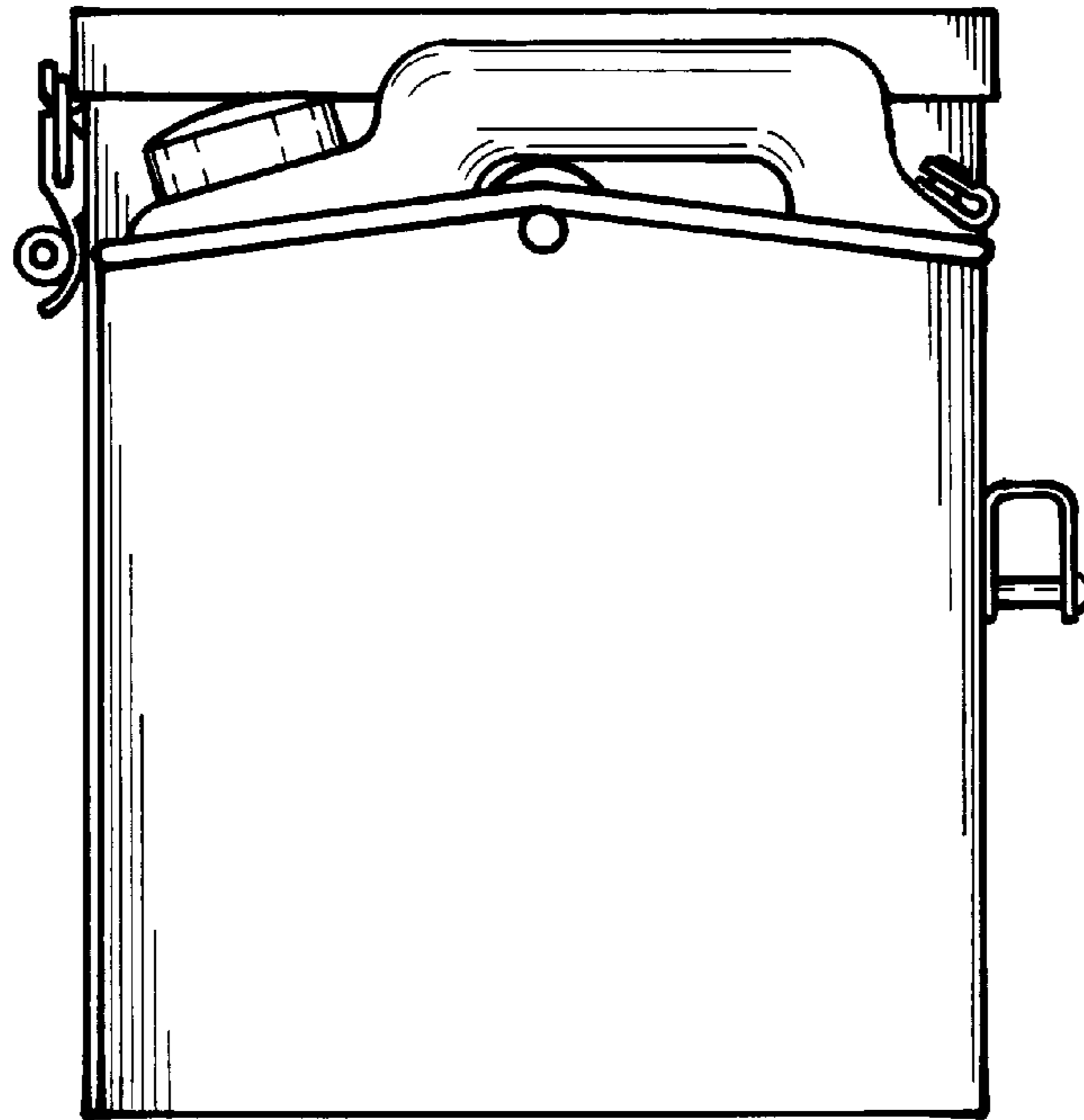

FIG. 11

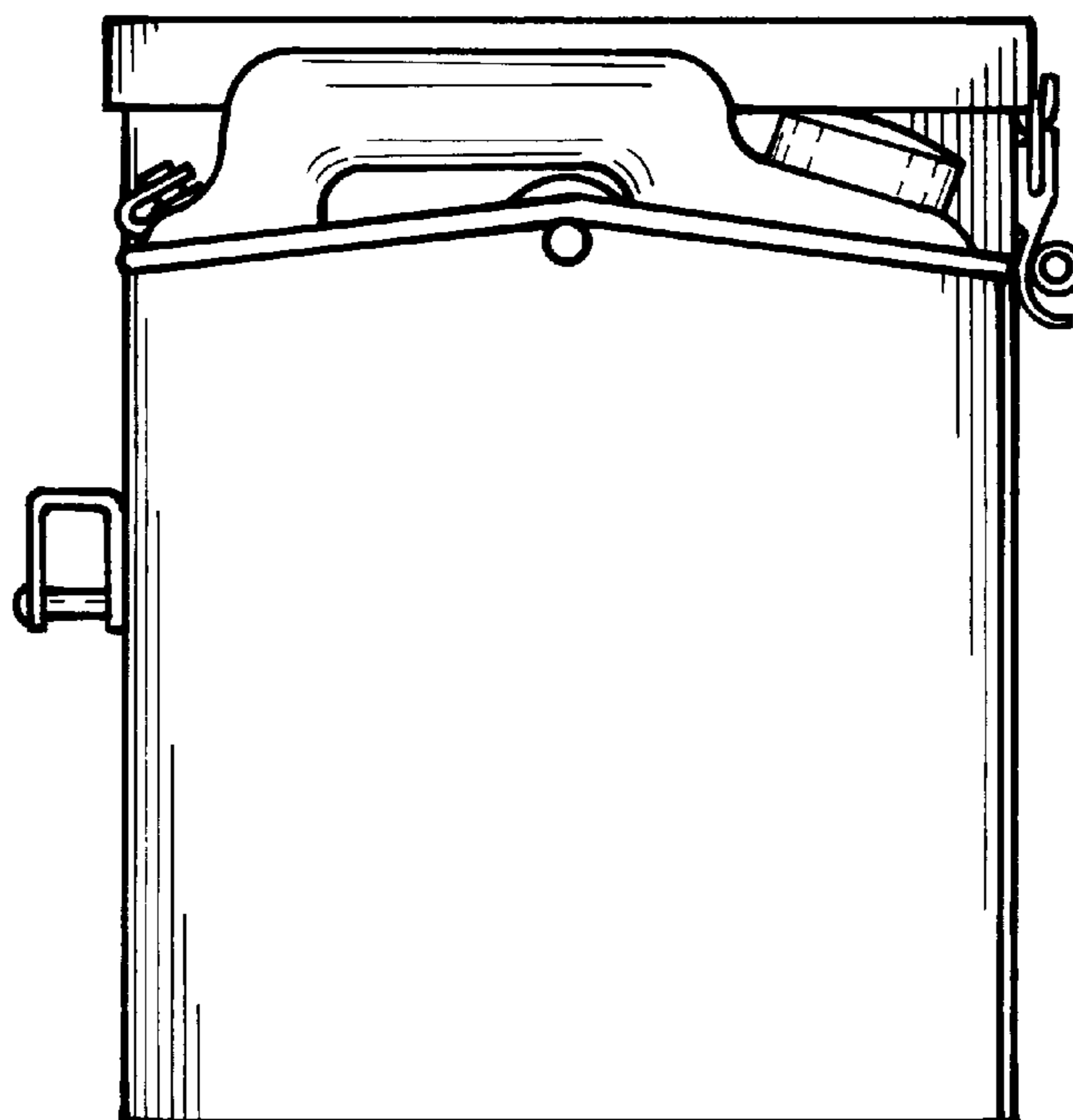

FIG. 12

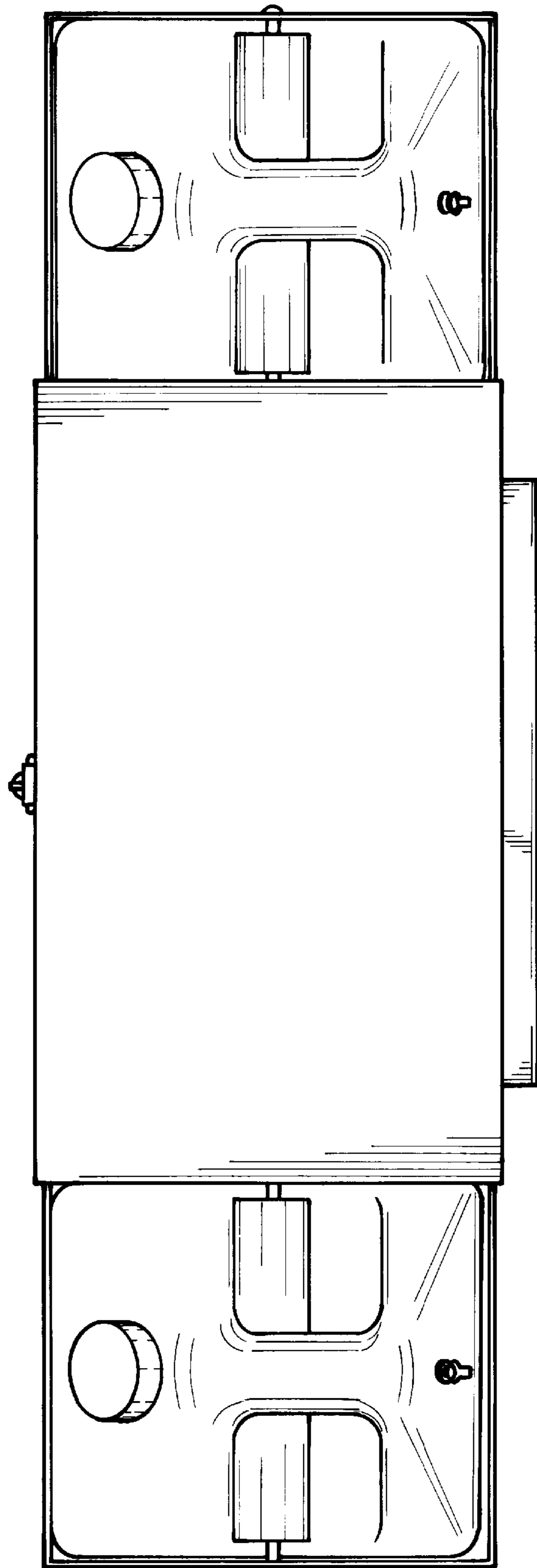

FIG. 13

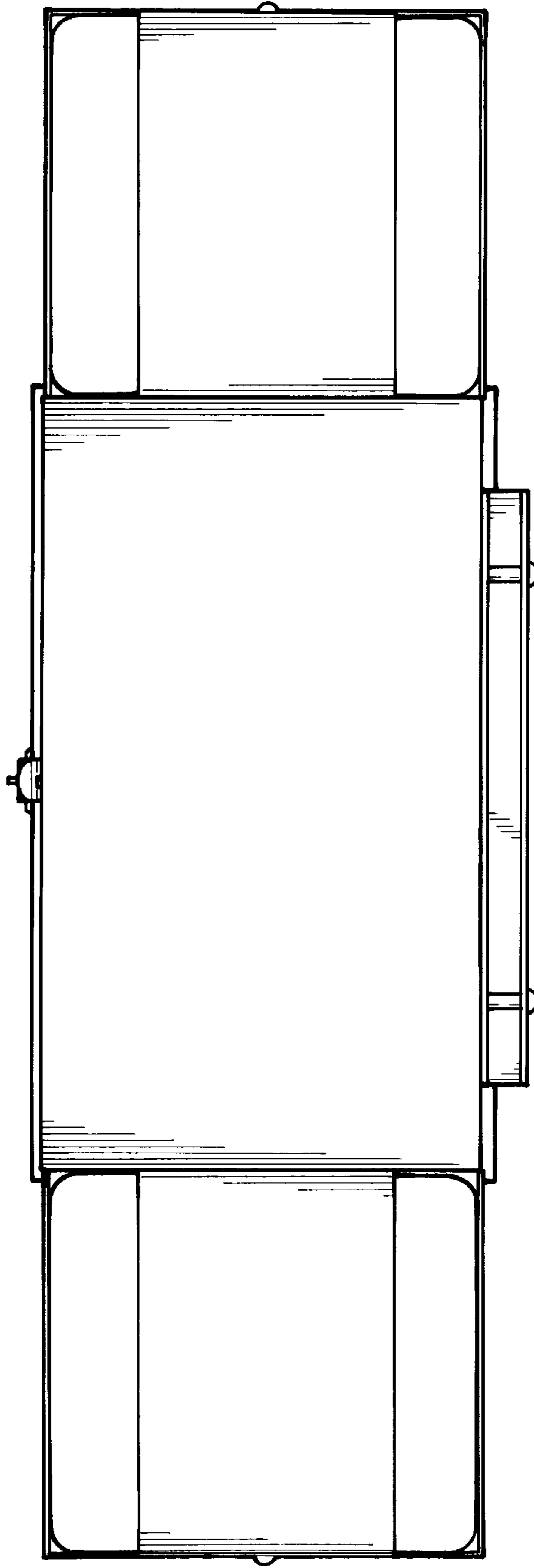

FIG. 14