



US00D417607S

United States Patent [19] Vining

[11] **Patent Number: Des. 417,607**

[45] **Date of Patent: ** Dec. 14, 1999**

[54] **HOLDER FOR RAILROAD SPIKES**

[75] Inventor: **Ed Vining**, Helena, Ala.

[73] Assignee: **Birmingham Rail & Locomotive/Vulcan Spike**, Birmingham, Ala.

[**] Term: **14 Years**

[21] Appl. No.: **29/095,981**

[22] Filed: **Nov. 3, 1998**

[51] **LOC (6) Cl.** **08-05**

[52] **U.S. Cl.** **D8/373; D8/376; D25/119**

[58] **Field of Search** **D8/376, 373; D25/119, D25/122, 123; 160/178.1; 248/251, 261, 262**

[56] **References Cited**

U.S. PATENT DOCUMENTS

- D. 344,595 2/1994 Ehmke et al. D25/119
- D. 345,498 3/1994 Fraser et al. D8/376

Primary Examiner—Holly Baynham
Attorney, Agent, or Firm—Robert J. Veal; Veal & Bush, LLC

[57] **CLAIM**

The holder for railroad spikes, as shown and described.

DESCRIPTION

FIG. 1 is a top front perspective view of a holder for railroad spikes showing my new design;
 FIG. 2 is a top rear perspective view thereof;
 FIG. 3 is a bottom front perspective view thereof;
 FIG. 4 is a bottom rear perspective view thereof;
 FIG. 5 is an end elevational view thereof;
 FIG. 6 is a sectional view along line 6—6 of FIG. 8;
 FIG. 7 is an end elevational view thereof;
 FIG. 8 is a top plan view thereof;
 FIG. 9 is a rear elevational view thereof;
 FIG. 10 is a front elevational thereof; and,
 FIG. 11 is a bottom view thereof.

The broken line showing of a railroad spike is for illustrative purposes only and forms no part of the claimed design.

1 Claim, 4 Drawing Sheets

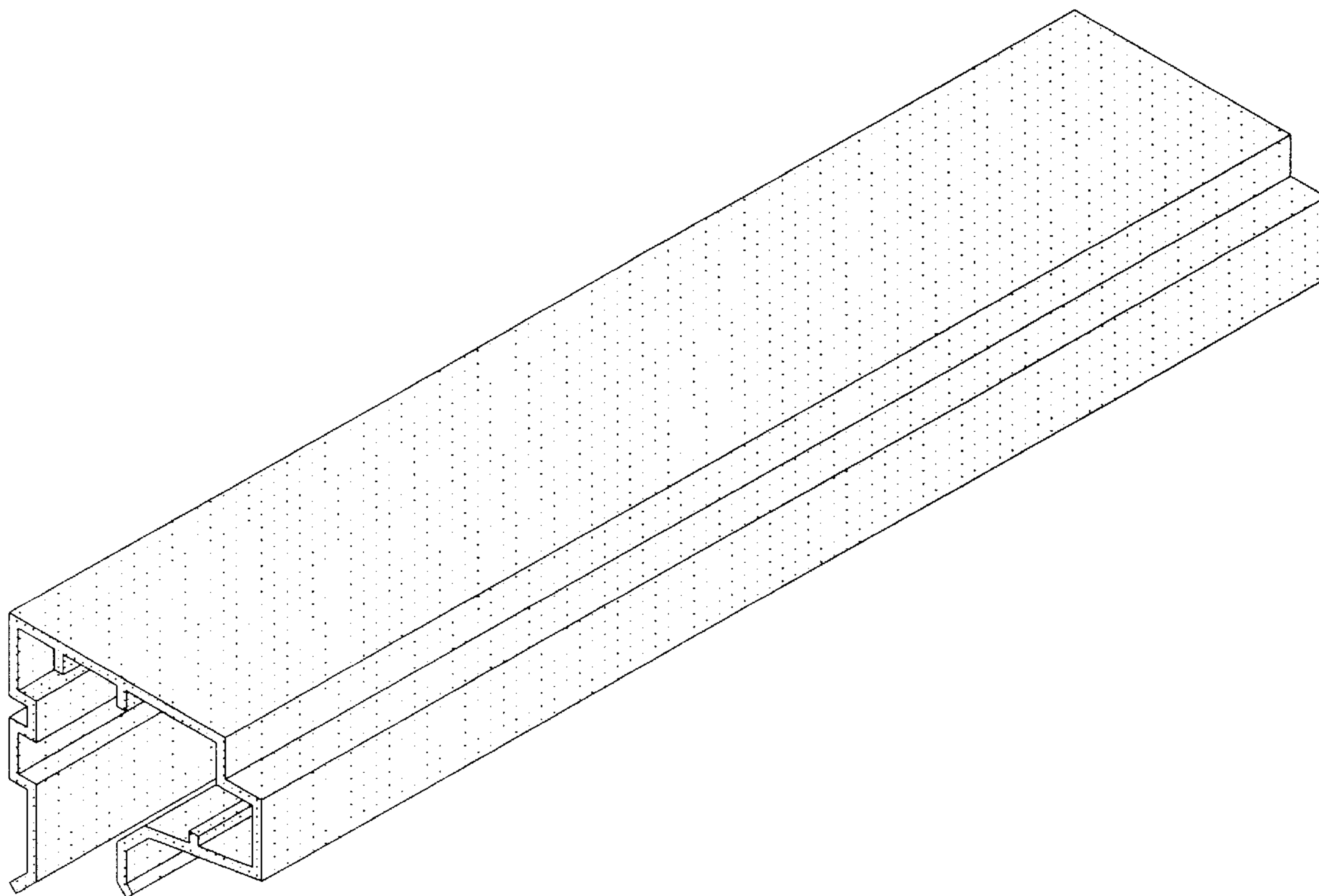

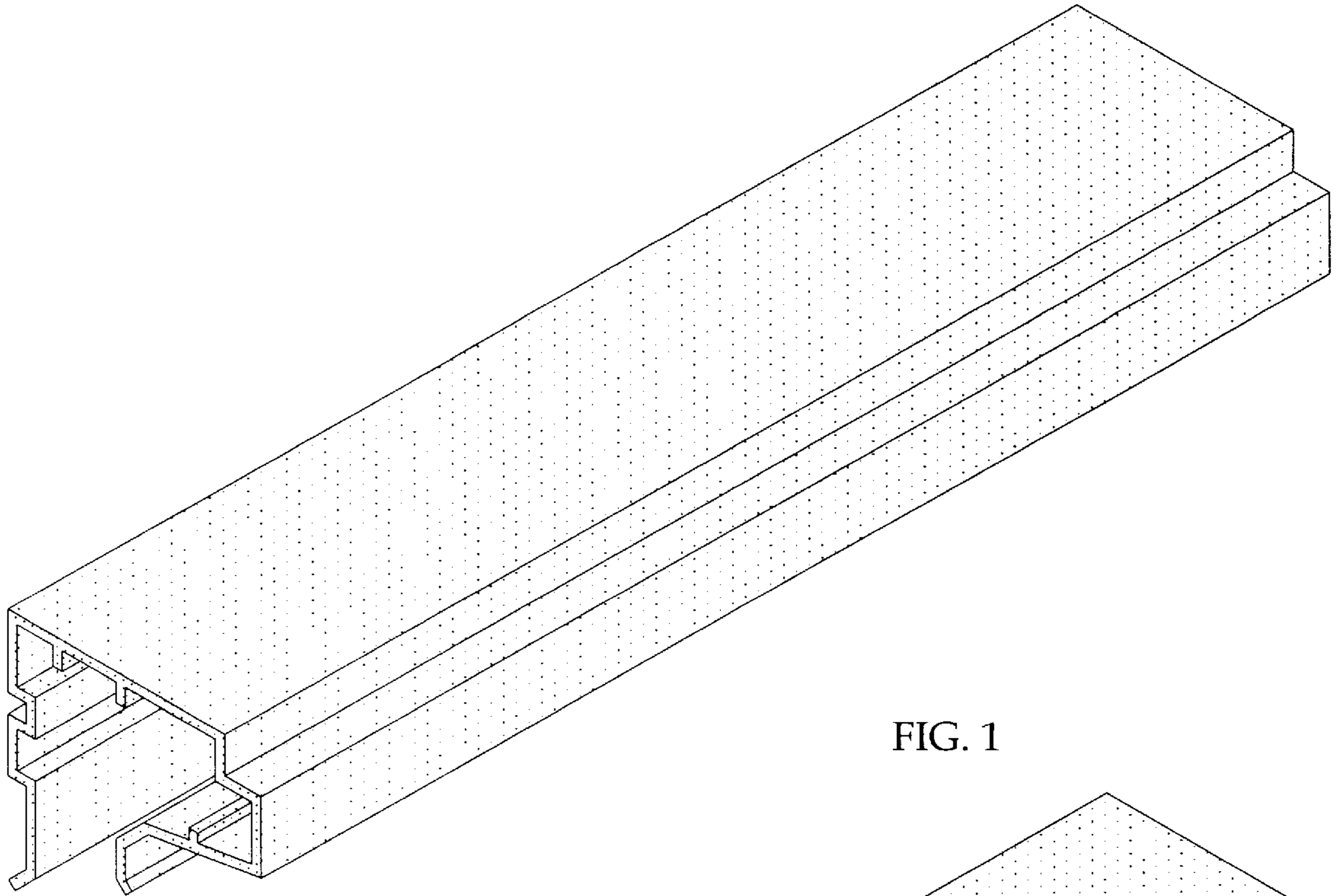

FIG. 1

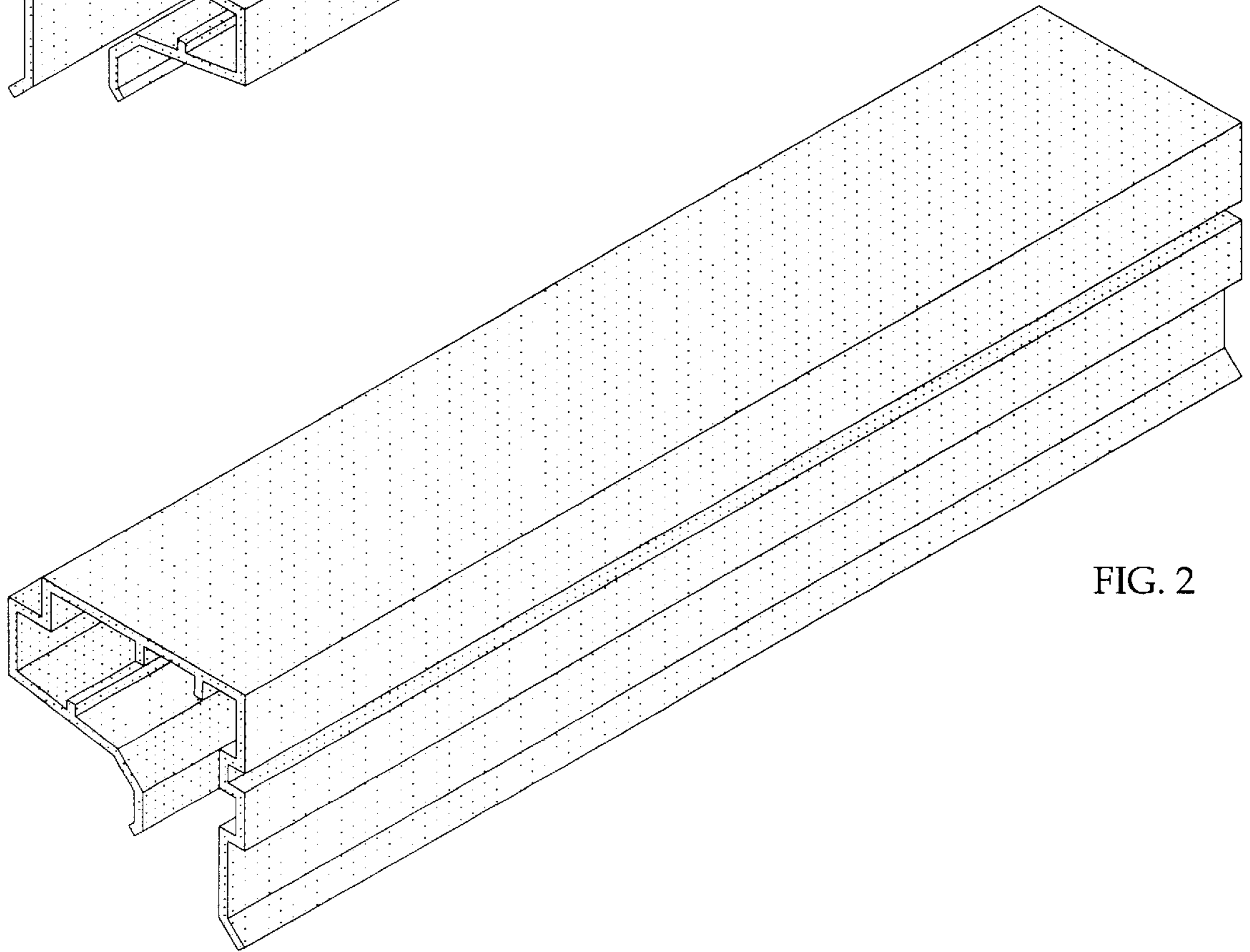

FIG. 2

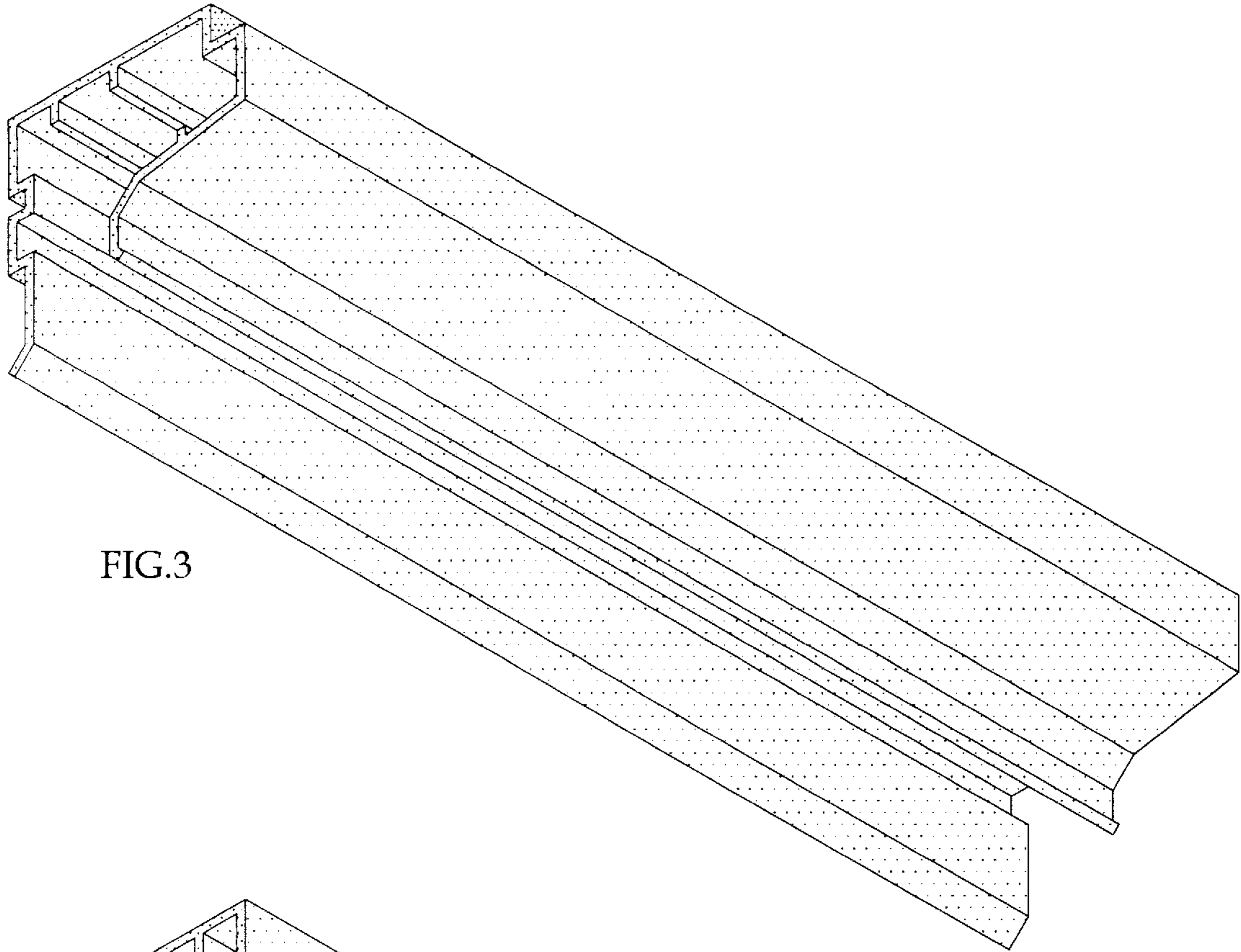

FIG.3

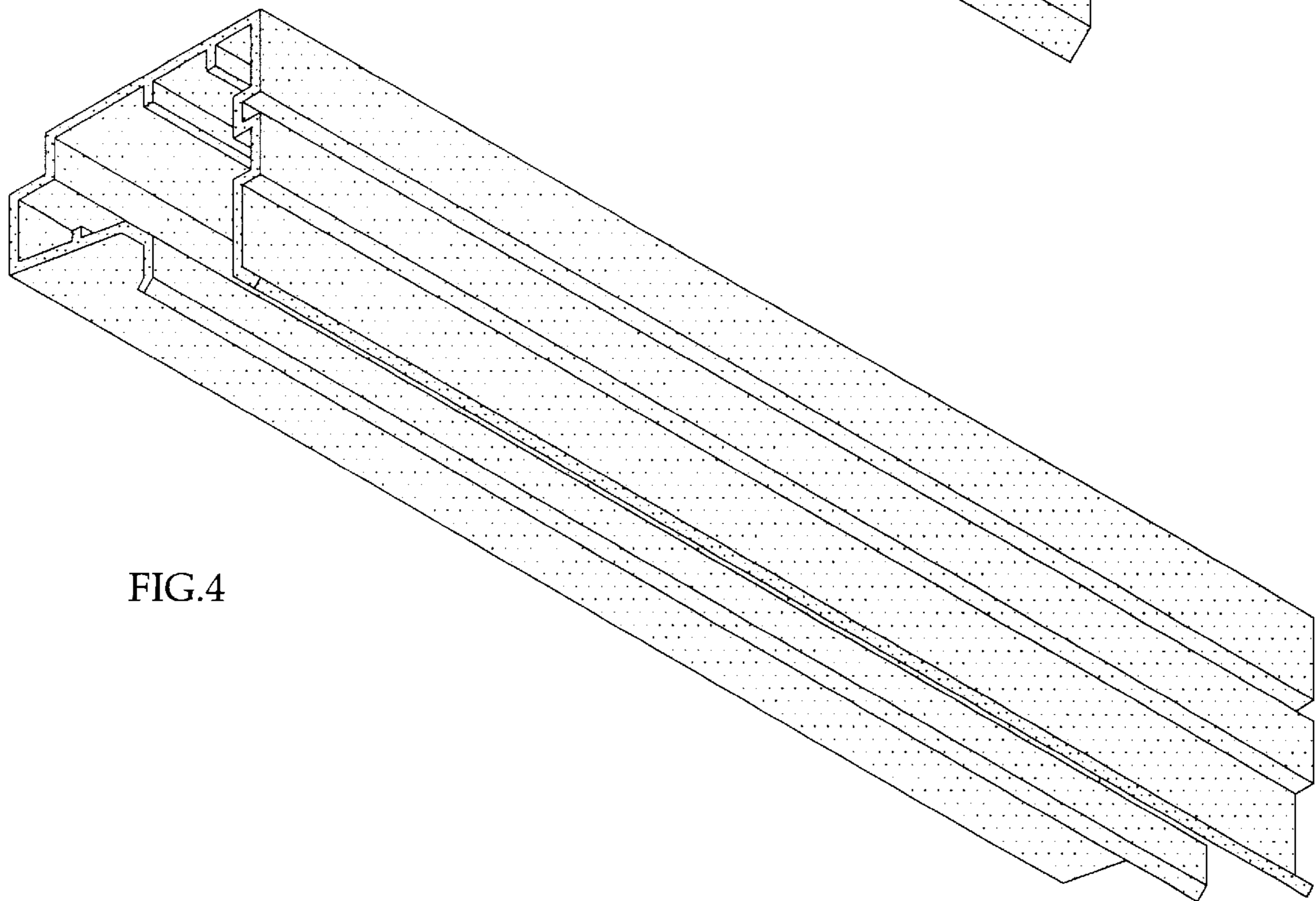

FIG.4

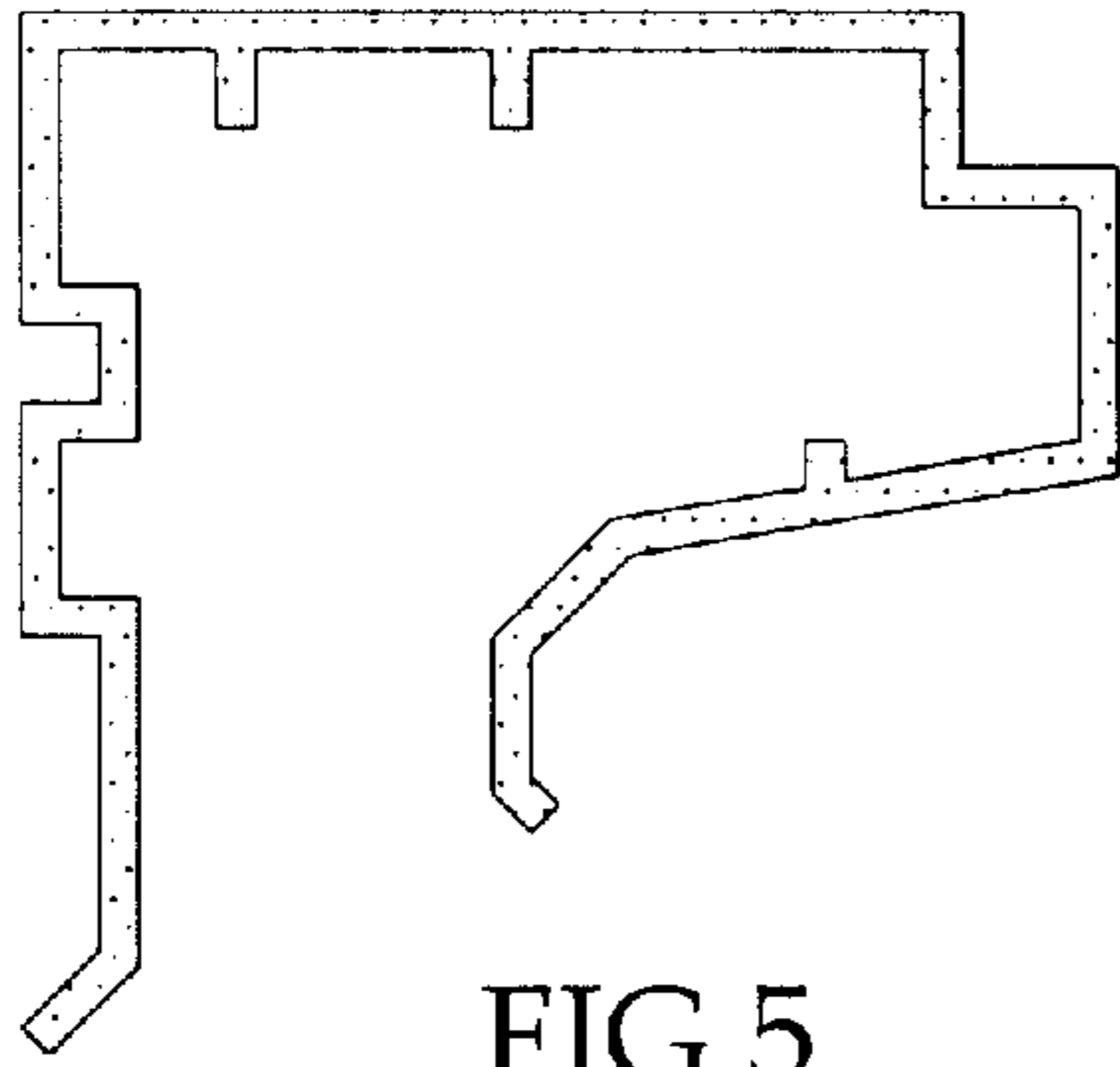

FIG. 5

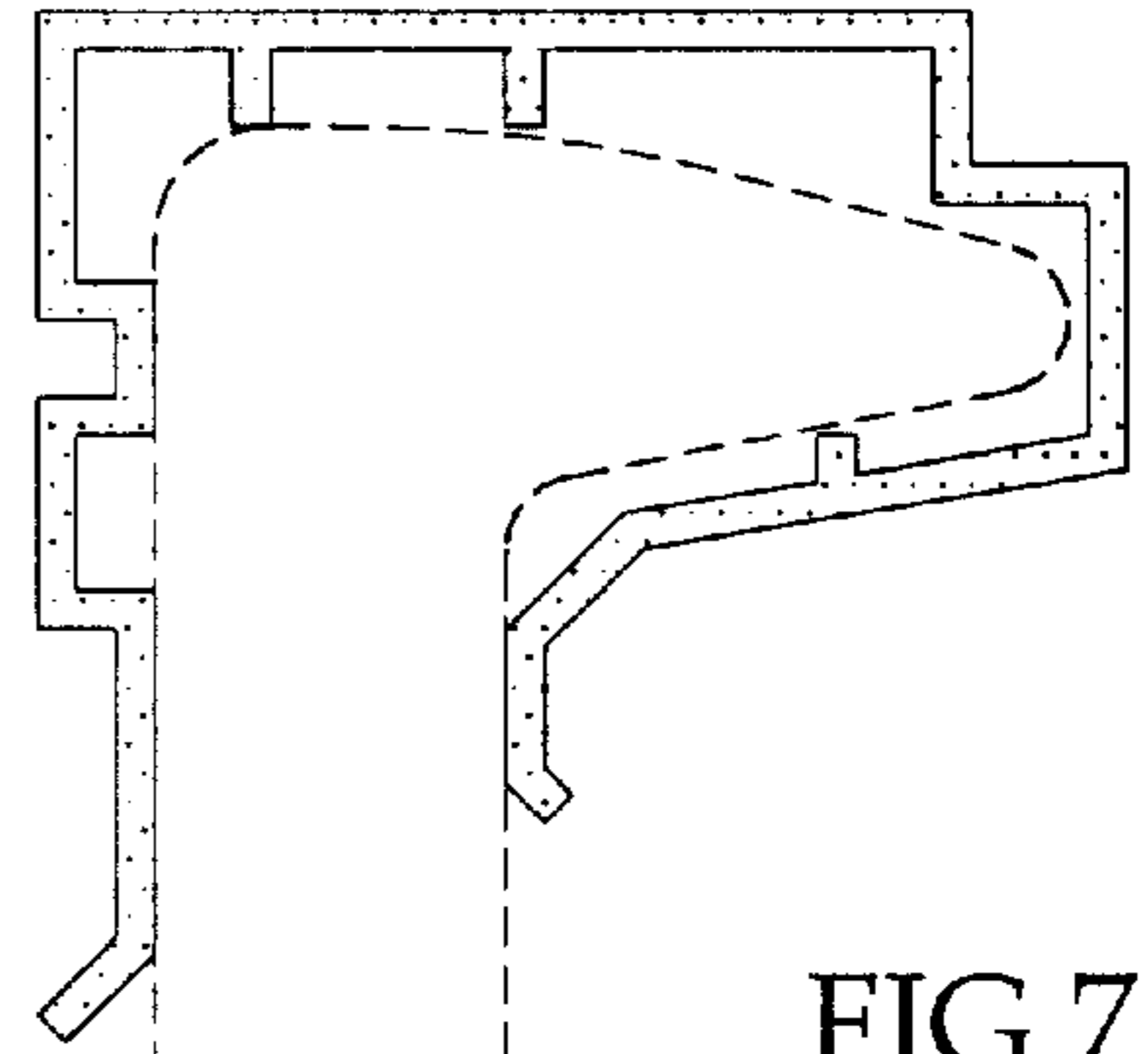

FIG. 7

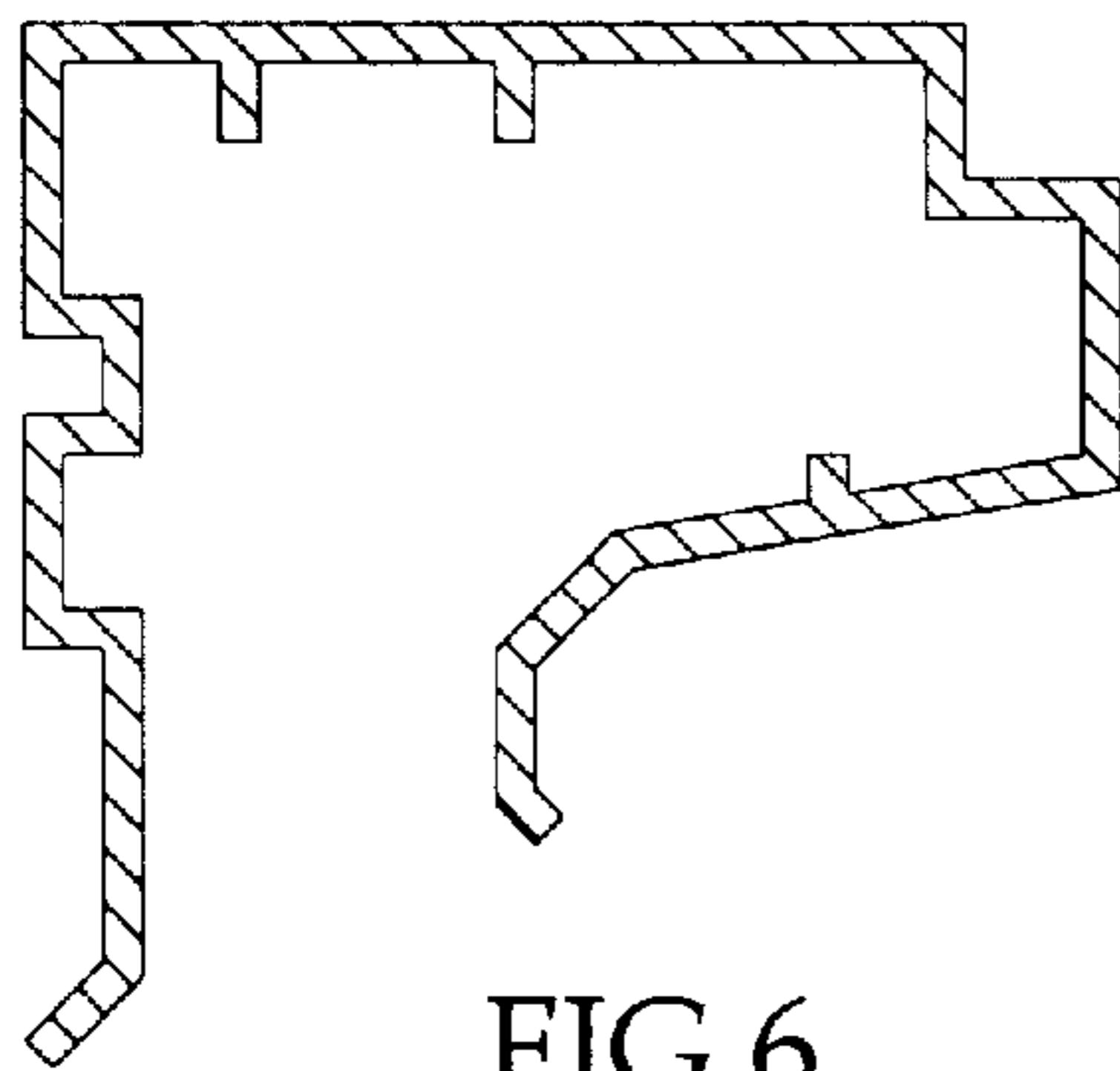
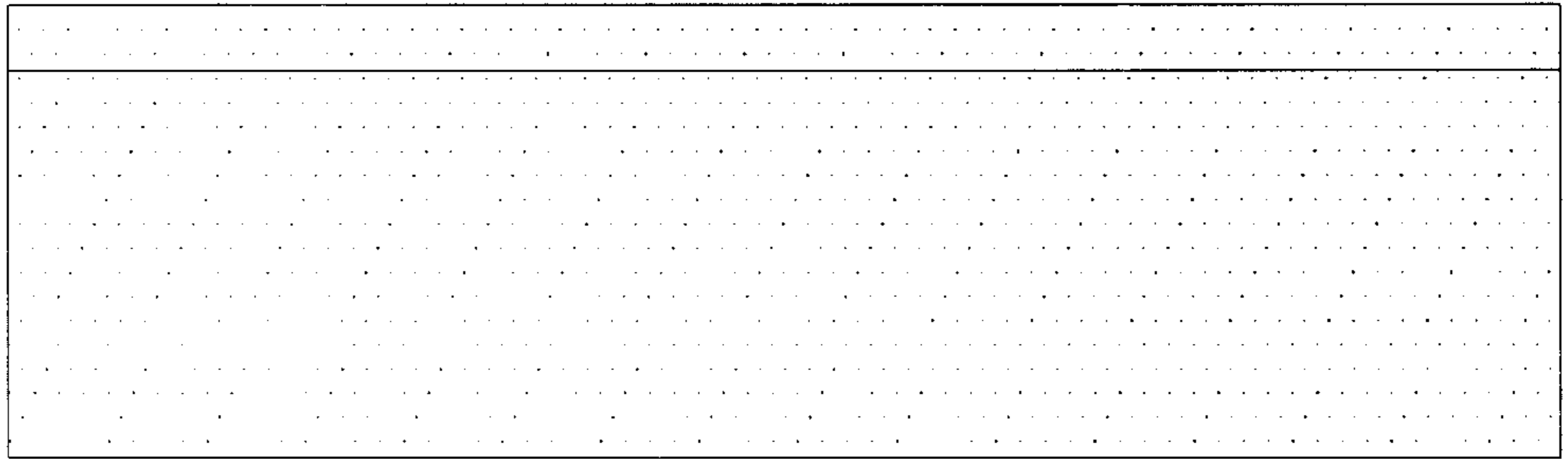

FIG. 6

6 ↖

FIG.8



6 ↖

FIG.9

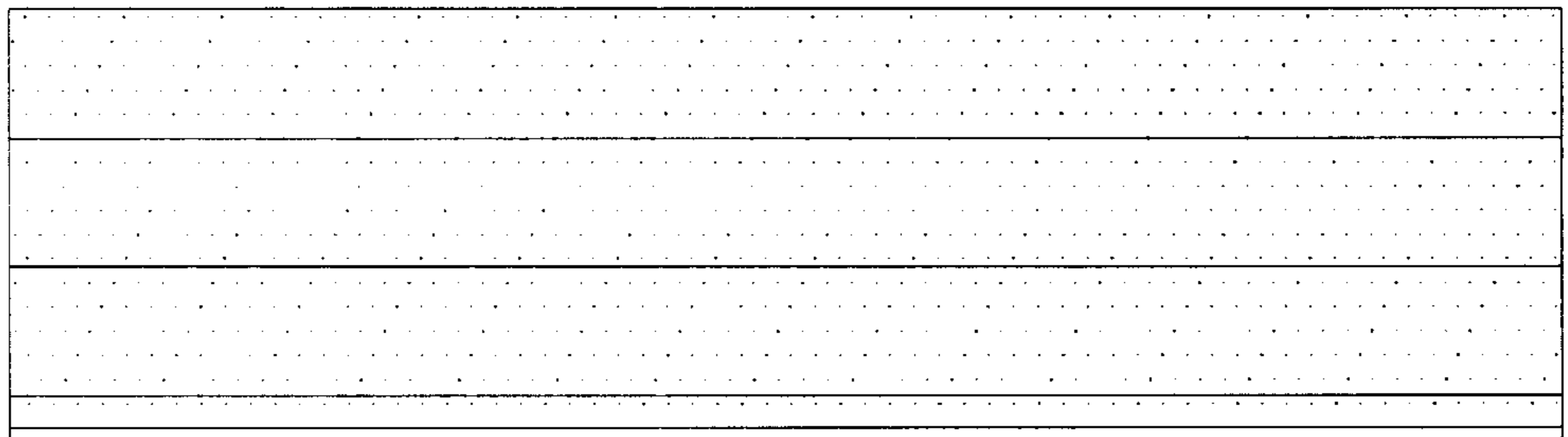

FIG.10

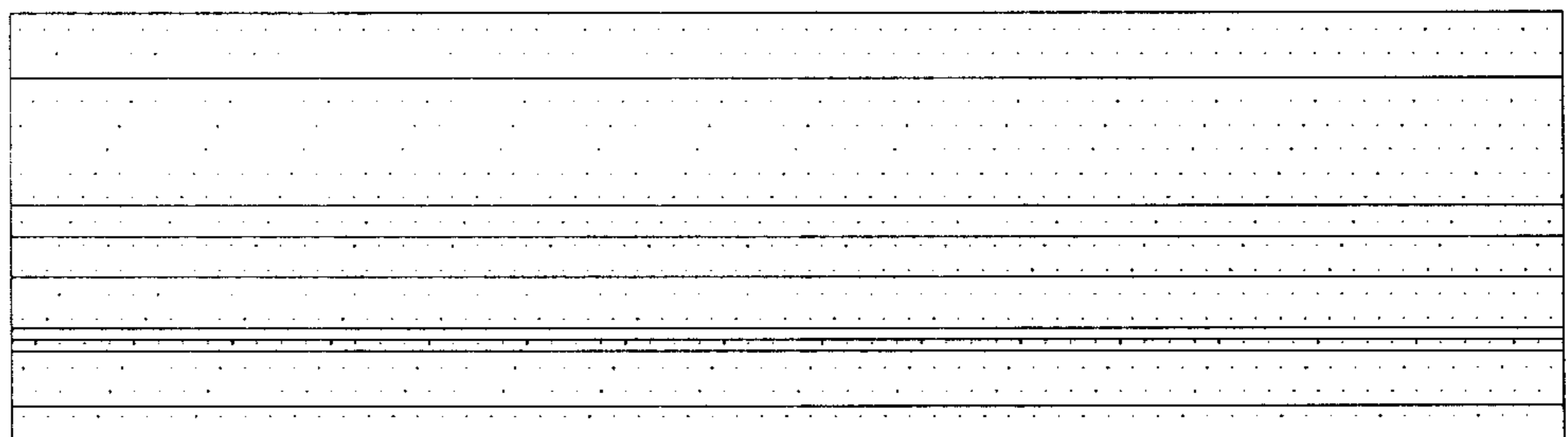

FIG.11

