



US00D417456S

United States Patent [19]

[11] Patent Number: Des. 417,456

Kulla

[45] Date of Patent: ** Dec. 7, 1999

[54] **FRONTAL SURFACE CONFIGURATION OF A DISPLAY PANEL FOR A MOTOR VEHICLE**

[75] Inventor: **Matthias Kulla**, Leonberg, Germany

[73] Assignee: **Dr. Ing. h.c.F. Porsche AG**, Germany

[**] Term: **14 Years**

[21] Appl. No.: **29/079,636**

[22] Filed: **Dec. 8, 1997**

[30] **Foreign Application Priority Data**

Jun. 6, 1997 [DE] Germany M 97 05 258

[51] **LOC (6) Cl.** **14-01**

[52] **U.S. Cl.** **D14/258**

[58] **Field of Search** D14/124, 137,
D14/157, 217, 257, 258, 299; 455/73, 90,
128, 345-347

[56] **References Cited**

U.S. PATENT DOCUMENTS

D. 248,301	6/1978	Gleaton	D14/257
D. 292,398	10/1987	Kifer et al.	D14/258
D. 345,737	4/1994	Muccioli et al.	D14/157 X
D. 364,878	12/1995	Green et al.	D14/258
5,477,432	12/1995	Magic et al.	D14/258 X

Primary Examiner—Nanda Bondade

Attorney, Agent, or Firm—Evenson, McKeown, Edwards & Lenahan, P.L.L.C.

[57] **CLAIM**

The ornamental design for a frontal surface configuration of a display panel for a motor vehicle, as shown and described.

DESCRIPTION

FIG. 1 is a front view of a frontal surface configuration of a display panel for a motor vehicle according to my novel design;

FIG. 2 is a perspective view from the top of a frontal surface configuration of a display panel for a motor vehicle according to my novel design;

FIG. 3 is a perspective view from the bottom of a frontal surface configuration of a display panel for a motor vehicle according to my novel design;

FIG. 4 is a perspective view from the left of a frontal surface configuration of a display panel for a motor vehicle according to my novel design;

FIG. 5 is a perspective view from the right of a frontal surface configuration of a display panel for a motor vehicle according to my novel design; and,

FIG. 6 is a perspective view from the bottom left of a frontal surface configuration of a display panel for a motor vehicle according to my novel design.

The broken line showing on FIGS. 1-6 is for illustrative purposes only and forms no part of the claimed design.

1 Claim, 2 Drawing Sheets

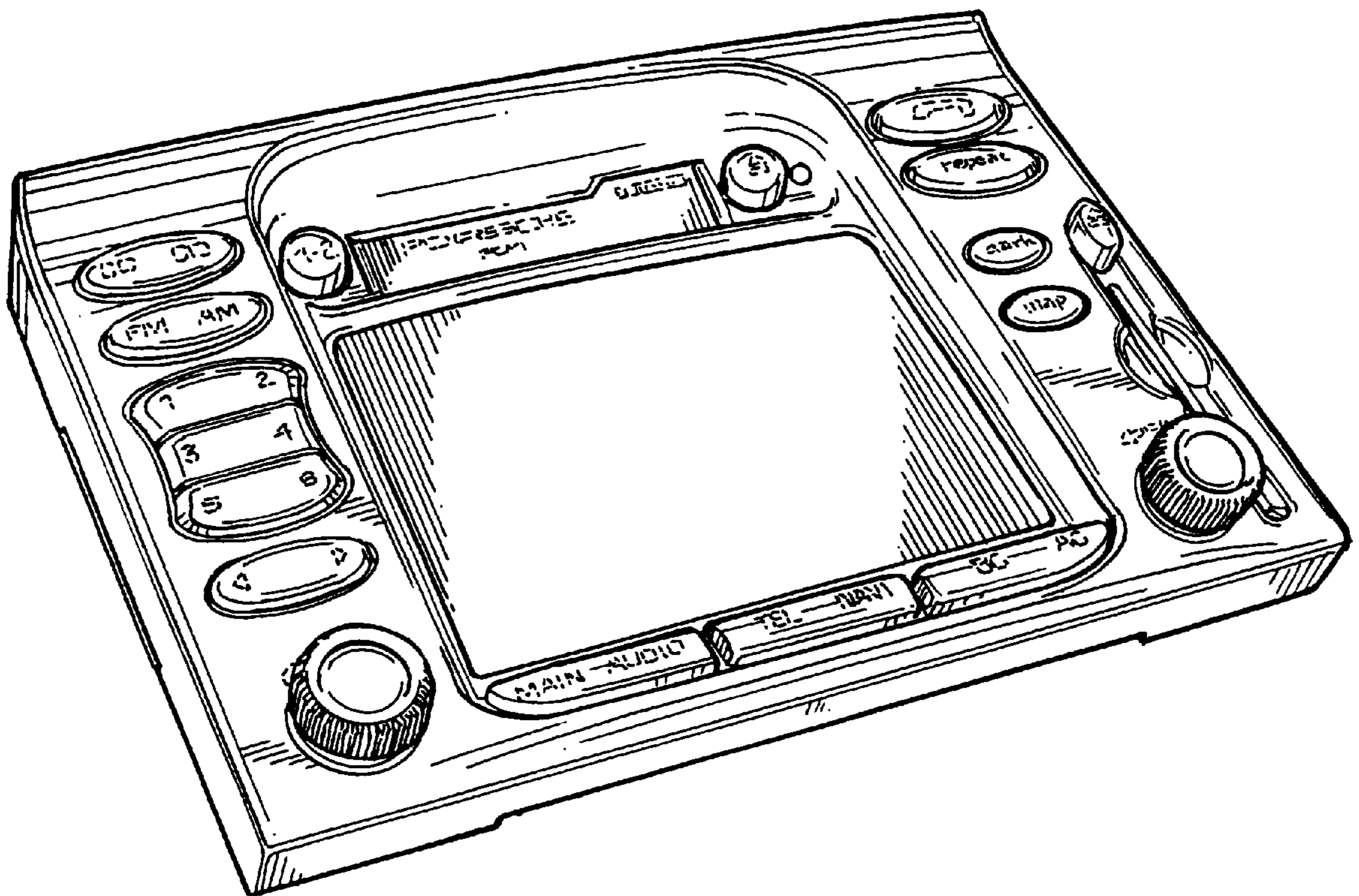

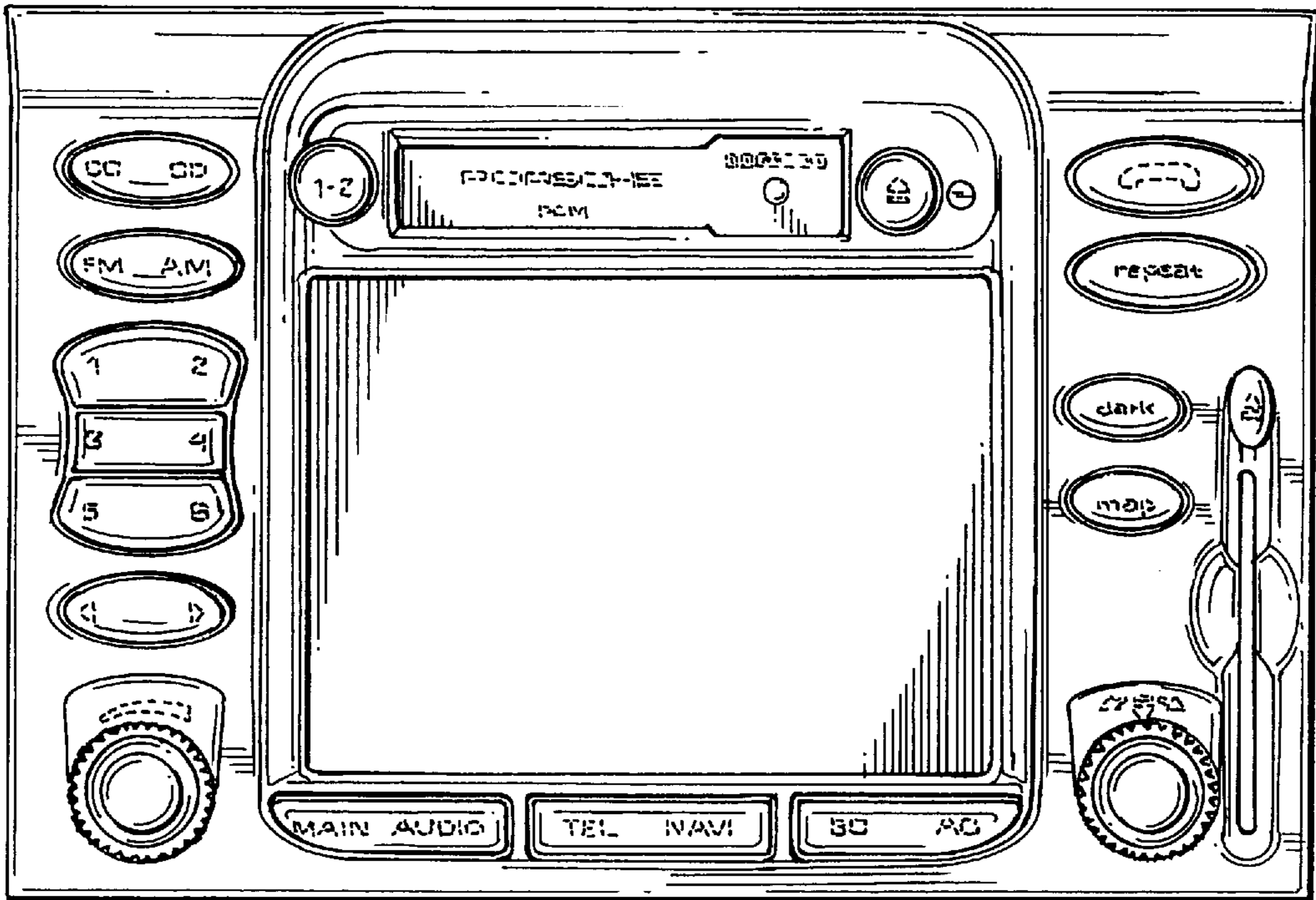

FIG. 1

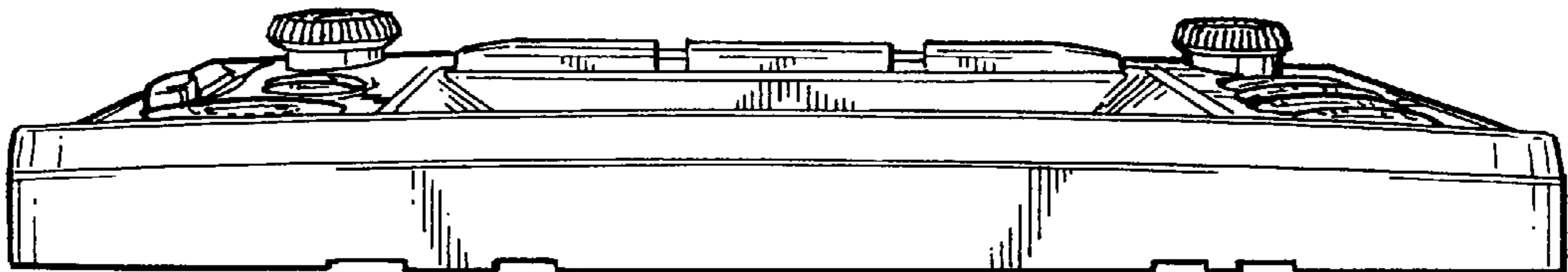

FIG. 2

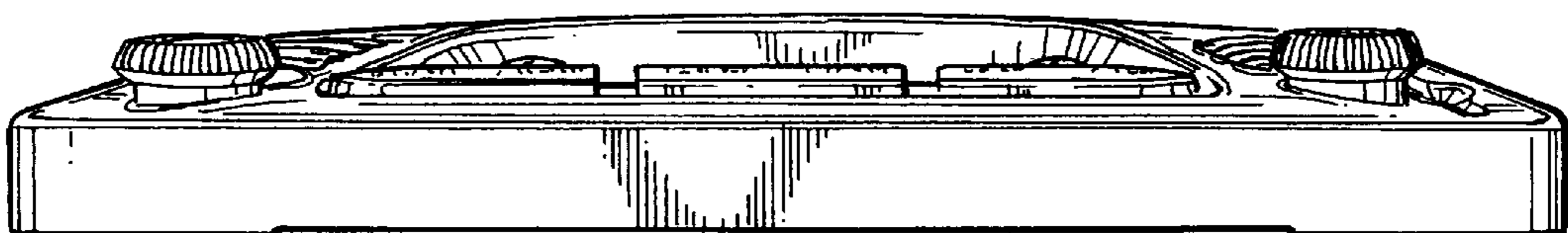

FIG. 3

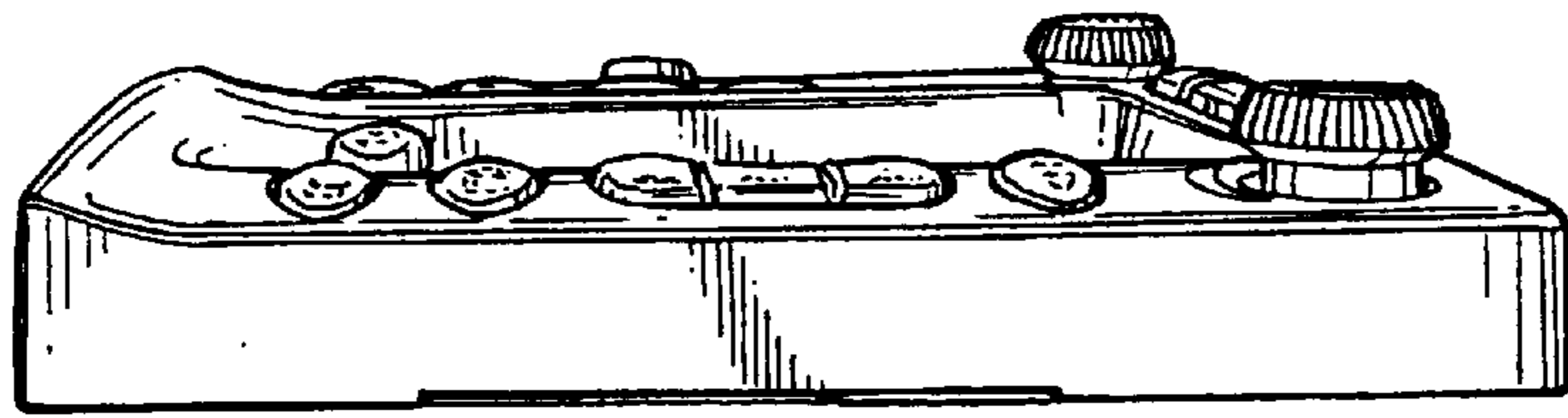

FIG. 4

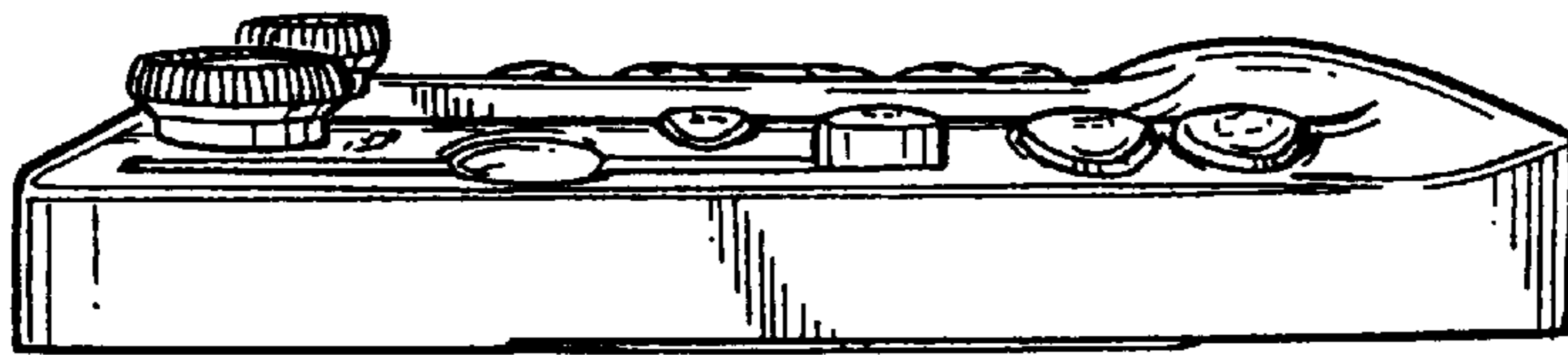

FIG. 5

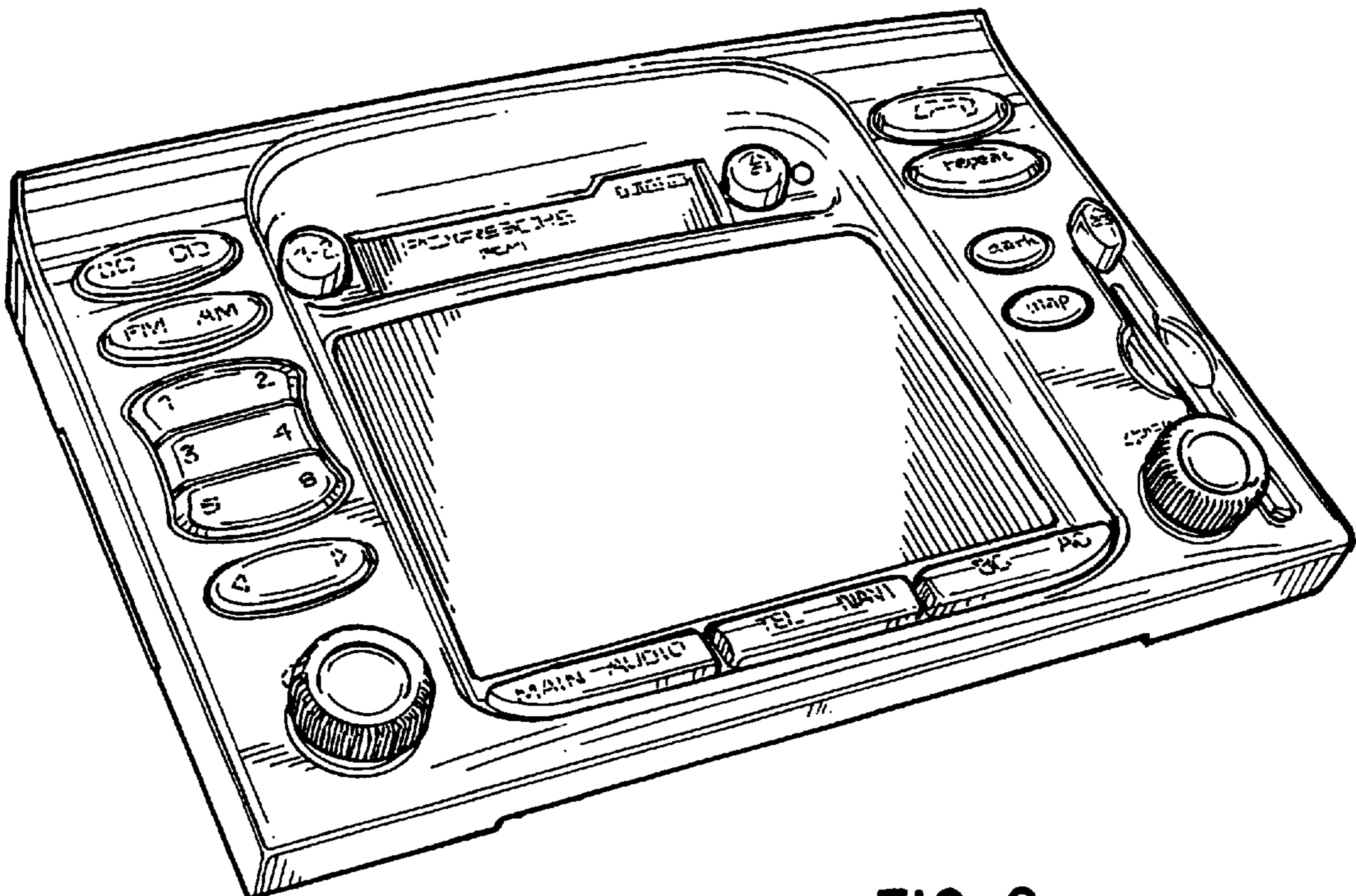

FIG. 6